

## Low Speed, High Torque Motors

Spool Valve: J, H, S, T, and W Series  
Disc Valve: 2,000, 4,000 Compact, Delta,  
4,000, 6,000, and 10,000 Series  
VIS: VIS 40, and VIS 45 Series

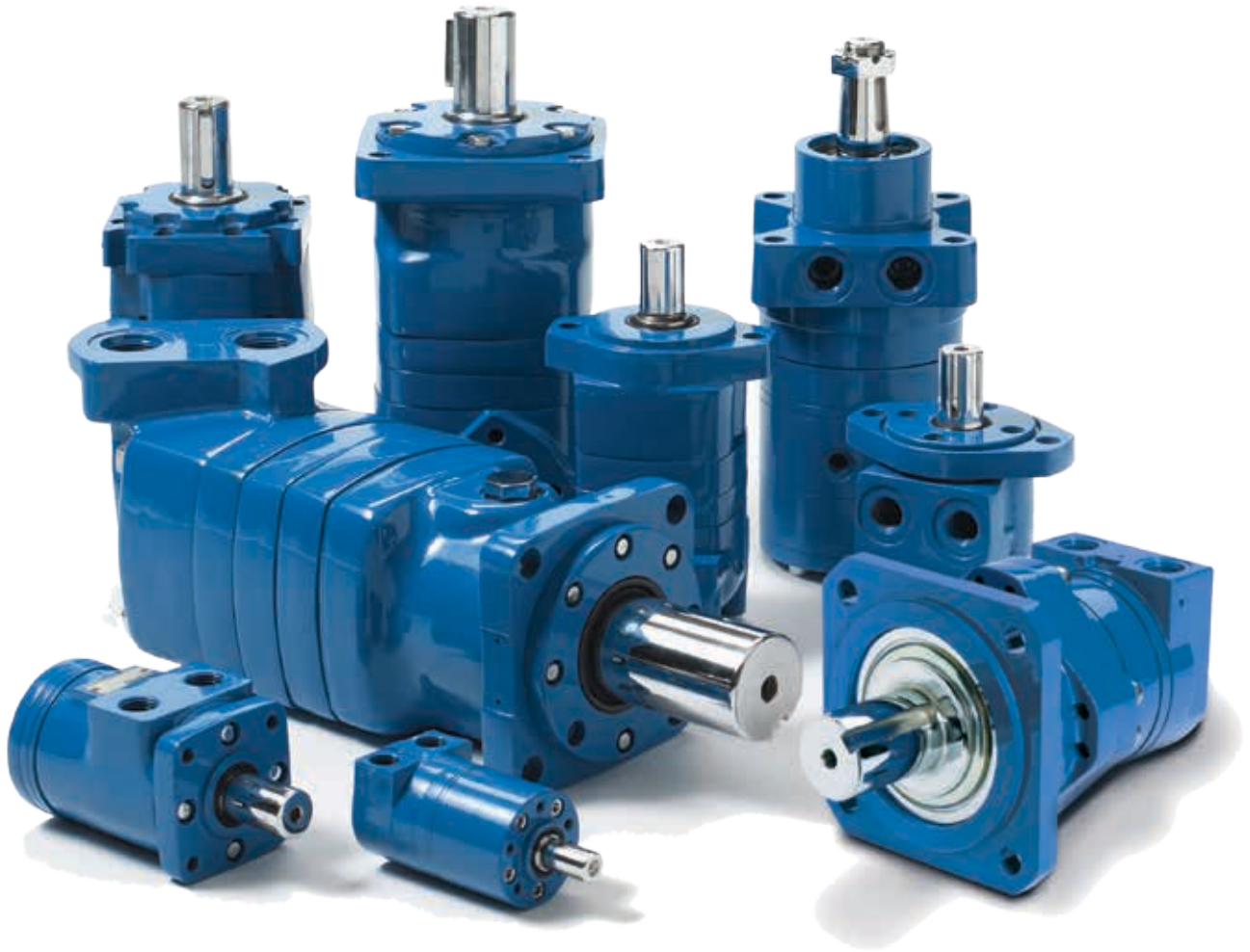

**EATON**

*Powering Business Worldwide*

# EATON

Powering Business Worldwide

## The Power of One Eaton

Celebrating  
**100** YEARS  
Ideals that Endure



Char-Lynn®



BOSTON  
WEATHERHEAD

Winner®



HANSEN™  
GROMELLE™

1911

1968

1971

1999

2000

2001

2002

2004

2005

2006

2007

2008

2010

2011

Airflex®



Walterscheid®

Synflex®



# EATON

Powering Business Worldwide

There's a certain energy at Eaton. It's the power of integrating the competencies of some of the world's most respected names to build a brand you can trust to meet every power management need. The energy created supports our commitment to powering business worldwide.

As the world's demand for high-efficiency hydraulic systems for mobile and stationary applications increase, Eaton is helping to solve these challenges more reliably, efficiently, and sustainably. Our goal is simple; to provide unique solutions across a wide range of markets that keep businesses on the leading edge of change. Visit [Eaton.com/hydraulics/fusion](http://Eaton.com/hydraulics/fusion).

**That's the power of One Eaton.**

# Serving eight key segments - sharing one focus



## Alternative Energy

Making energy sources technically practical and economically sound requires the kind of control made possible by high-quality components. When Eaton is on the inside, you will experience the reliable, consistent performance to create and capture energy—making renewable energy an every-day energy.



## Discrete Manufacturing

Produce at peak efficiency with the superior precision and repeatability of Eaton products. Eaton hydraulic components provide the precise control and consistent operation required for virtually every step in your manufacturing operation. With Eaton, we'll help you redefine the meaning of raw productivity.



## Oil & Gas

As the oil & gas industry continues to face further globalization and consolidation, large-scale organizations that can meet your needs in every corner of the world are more difficult to find. At Eaton, our portfolio of products is only surpassed by our tremendous reach.



## Processing

Whatever your industry, no matter which processes you manage, Eaton parts and systems help keep you up and running. Our components make equipment more efficient and easier to use, so you get optimal machine performance and maximum productivity.



## Agriculture & Forestry

There's a reason farming and forestry are called "working the land." These segments involve some of the hardest work and longest hours of any sector in the economy. Your productivity and profitability depend on the way you manage time and tasks.



## Commercial Vehicles

Eaton technologies can make your driving operation more successful. Greater comfort and productivity help increase driver retention, while reduced emissions, leaks, and noise improve environmental performance. Increased efficiencies overall mean lower costs and higher net revenue.



## Material Handling

Eaton hydraulic systems provide the precise control and consistent operation required for material handling and utility work. With a broad selection of products and solutions built in, Eaton helps make you a master of your domain.



## Construction & Mining

When you work on a large scale, even the details are big. You need to trust every part of the equipment that lets you handle construction and mining jobs. For reliable components that deliver consistent performance in extreme conditions, turn to Eaton.

## Eaton is a leading diversified power management company

Eaton provides reliable, efficient and safe power management for a growing number of industries.

### Understanding and helping our customers succeed

- Listening and understanding to requirements and business drivers
- Delivering solutions with value propositions to solve the critical business needs

### Knowing what's important to our customers and integrating that knowledge into the fabric of our business

- ...to deliver innovative, quality products
- ...to respond fast
- ...to provide dedicated customer service and support around the globe

### Our strength is global reach with local responsiveness and support

- Customers served in more than 150 countries
- Diverse channels ensure reliable availability and support
- Design and engineering teams provide support for standard products and custom solutions
- Eaton experts offer efficient product and application training

# Contents

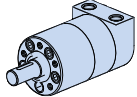
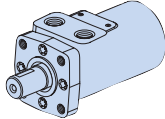
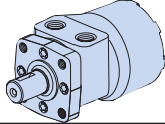
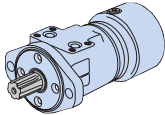
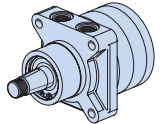
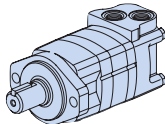
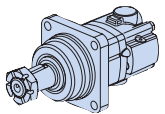
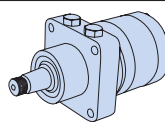
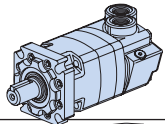
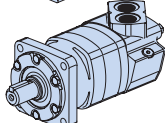
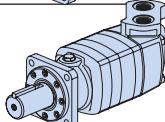
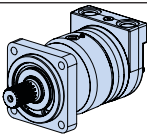
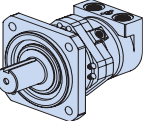
	SECTION	PRODUCT NUMBER PREFIX	PAGE	
	Introduction to Eaton Motors		A-3	A
	J Series	(129-)	B-1-1	B-1
	H Series	(101-)	B-2-1	B-2
	S Series	(103-)	B-3-1	B-3
	T Series & "T" Series w/Parking Brake	(158-) (185-)	B-4-1	B-4
	W Series & W Series w/Parking Brake	(162-)	B-5-1	B-5
	2000 Series	(104-, 105-, 106-, 193-)	C-1-1	C-1
	4000 Compact Series	(167-, 169-, 170-)	C-2-1	C-2
	Delta Series	(184-)	C-3-1	C-3
	4000 Series	(109-, 110-, 111-)	C-4-1	C-4
	6000 Series	(112-, 113-, 114-)	C-5-1	C-5
	10,000 Series	(119-, 120-, 121-)	C-6-1	C-6
	VIS 40 & VIS 40 w/Parking Brake	(168-, 176-, 177-, 178-, 180-, 182-)	D-1-1	D-1
	VIS 45	(155-, 156-, 157-, 173-, 174-, 183-)	D-2-1	D-2

## Contents

Char-Lynn, Hydraulic Motors	A-3
Circuits	A-4
Design Flexibility	A-5
Motor Application Information	A-6
Optional Features	A-8
Two Speed Motors	A-11
Seal Guard	A-12
Viton Seals	A-12
High Pressure Seals	A-13
Braking Solution	A-14
Free Running Geroler Sets/Gerotor Sets	A-15
Speed Sensors	A-16
Shuttle Valve	A-17
Case Porting	A-18
Low Speed Valving	A-19
Nickle Plating Option	A-20
Integral Valves for 2000 Series	A-21
Bolt-On Valve Solutions for Char-Lynn Motors	A-22
Overcenter Packages for H&T Series Motors	A-23
Overcenter Packages (w/shuttle) for H&T Series Motors	A-25
Cross-Over Relief Packages for H&T Series Motors	A-27
Overcenter Packages for 2000 Series Motors	A-28
Overcenter Packages (w/shuttle) for 2000 Series Motors	A-30
Cross-Over Relief Packages for 2000 Series Motors	A-32
ATEX Certification	A-33
Fluid Recommendations	A-34

## Introduction

For the past 45 years, the Char-Lynn®, brand has been recognized as the industry leader in low-speed, high-torque (LSHT) hydraulic motor technology. The name Char-Lynn was coined by one of the original pioneers in the hydraulic industry, the late Mr. Lynn Charlson. The hydraulic motor designs developed by Lynn Charlson and his team use what is termed as the Orbit principle. This principal is the center of the designs pioneered by the Char-Lynn team and is based on the fact that a gerotor or Geroler®, star orbits multiple times (typically 6 to 8 times depending on specific star and ring geometry) for each complete single revolution within the outer ring. This principle is what gives Char-Lynn motors their reliable high power density and extremely compact size. Only three primary moving components are needed to transmit torque through the motor: star, drive and output shaft. Shaft rotation can be instantly reversed by changing inlet / outlet flow while generating equal torque in either direction. A variety of displacement sizes are available in each motor family that provide a wide variety of speeds and torque ranges from any series of motors. The results are compact, modular, economical designs that can be easily customized to suit a wide variety of application needs.

## Motor options include:

- Displacement size (cubic inches or cc's per revolution)
- Output shaft size and type
- Mounting flange type
- Porting interface
- A wide selection of special features such as integrated brakes, sensors, integrated cross-over relief valves, 2-speed capability, manifold valve packages, and environmental protection suited for corrosive environments.

Char-Lynn motors are extremely reliable, compact, and have tremendous power density. They provide a way to meet many needs for cost-effective power transmission requirements. Multiple motors can be driven by a single power source (pump) and controlled using a wide array of valves and variable displacement pump controls. Motors can even be configured with electronic sensors to provide digital feedback for sensing both motor direction and

output speed.

The Char-Lynn motor range consists of three major types based on the type of valving used to distribute fluid through the Orbit gear set (geroler or gerotor). These three types are:

- **Spool Valve**
- **Disc Valve**
- **VIS (Valve-in-Star)**

Migration from one valve technology to the next enhances motor performance in terms of efficiency, pressure rating, displacements, and motor output torque capability.

To help guide you to proper product selection, a quick guide is provided below. In addition, you will find product highlights, summaries of motor option features and benefits, application formulas, and detailed specifications for each motor family.

## MOTOR QUICK-GUIDE (BASED ON MAXIMUM CONTINUOUS RATINGS)

Type	Output Torque Nm [lb-in]	Pressure bar [psi]	Flow lpm [gpm]	Side Load kg [lbs]
Spool Valve	441 [3905]	165 [2400]	62 [18]	725 [1600]
Disc Valve	2700 [24000]	205 [3000]	170 [45]	4500 [10000]
VIS (valve-in-star)	4520 [40000]	345 [5000]	170 [45]	8640 [19000]

# Circuits

## Circuit Design Considerations

### Hydraulic Circuit

Hydraulic drives can be divided into two basic types: 1) Traction Drives and 2) Non-Traction drives. Traction drives (also referred to as propel drives) are used to propel a wheeled or track-driven vehicle. Non-traction drives (also referred to as work drives) are used for some other vehicle function such as a winch, auger, conveyor or rotate function for a boom or crane.

These rotary drive systems can also be classified as either open loop or closed-loop circuits.

### Open Loop Circuit

In an open loop circuit, oil is returned to a reservoir before returning to the motor. The motor/pump circuit is open to atmosphere. In an open loop circuit, the drive speed of a motor may be controlled by, varying the flow with a valve, changing pump input speed (engine or pump input speed), or varying flow using a variable displacement pump. Often these circuits use counter-balance valves to accomplish dynamic braking functions, and provide a flow (pressure) source to release a spring-applied, hydraulic release brake. It is common to use a shuttle valve for directing flow to release the spring-applied pressure-release brake. A shuttle valve is basically a double check valve that directs flow from the A or B side of the loop and is often the source of flow to create the pressure to release a brake.

Typical applications using open loop circuits include:

- Truck-Mounted Booms and cranes (boom – rotate function)
- Aerial Work Platforms (boom – rotate function)
- Winches
- Conveyors
- Grapples
- Others

### Closed Loop Circuit

In a closed loop circuit, there is no reservoir between the inlet and outlet of the motor and pump. The pump outlet is connected directly to the motor inlet and the motor outlet is connected directly to the pump inlet. This circuit is, in theory, closed to atmosphere. Motor speed is typically controlled using a variable displacement pump. This pump can also control motor output shaft direction (CW or CCW rotation).

These systems provide dynamic control of flow through the closed loop of the motor/pump circuit. They are, however, subject to some inherent internal leakage that results in the inability of the loop to hold a load over time. This is why a static brake is typically found in such systems to mechanically hold the load. Brakes used include mechanical caliper, disc or ball-ramp type brakes. In addition, spring-applied, hydraulic release brakes are used. The T Series Motor w/ Parking Brake meets this need.

Typical applications using closed loop circuits include:

- Vehicle traction drives (propel function)
- Conveyors
- Winches
- Others

Char-Lynn motors are truly built for high torque low speed. A lot of power is derived from this small package. This power advantage provides the designer with a product that can be used for overall compactness in addition to taking full advantage of the high pressure ratings typical of present day hydraulic components.

Char-Lynn hydraulic motors allow the designer to put the power where it is needed. Furthermore, the motors can be mounted directly on the driven device away from the original power source which eliminates the need for other mechanical linkages such as chains, sprockets, belts, pulleys, gears, rotating drive shafts, and universal joints. Several motors can be driven from the same power source and can be connected in series or parallel to each other.

### Case Drain and Shuttle Valve Options

Many hydraulic systems can benefit from the use of a system case drain. Char-Lynn motors provide this feature built in. One

### Durability

The design and method of manufacture of three critical drive train components: valve drive, shaft drive, and output shaft, give these motors durability. Consequently, the motors stand up against high hydraulic pressures.

### Performance Rating

Our method of rating these motors recognizes that at slower speeds and flow, higher pressures and torque are permitted. Hence, our performance data shows the complete flow range (down to 1 liter per minute or 1/4 gallon per minute) and speed range (down to one revolution per minute depending on application).

### Controllable Speeds

Char-Lynn motors operate at low speeds that remain very near constant even when load varies. Shaft speed is varied smoothly, easily and economically using simple inexpensive controls. Also, these motors are reversible. Consequently, direction of shaft rotation can be changed instantly with equal output torque in either direction.

### Dependable Performance

Highly precise manufacturing of parts provide consistent, dependable performance and long life even under varying conditions.

### Reliability

Char-Lynn motors are self contained, with hydraulic fluid providing lubrication. These motors are completely sealed so they can operate safely and reliably in hostile environments such as dust, dirt, steam, water, and heat and provide reliable performance.

### High Efficiencies

Char-Lynn motors efficiently convert the supplied hydraulic fluid's pressure and flow into a low speed high torque rotational output. This efficiency minimizes the rate of hydraulic system heat generation and maximizes shaft horsepower.

of the advantages for case drain flow is that contamination is flushed from the system. This flushing also aids in cooling the system and lowering the case pressure which will

extend motor seal life. With a case drain line in place, oil pressure in the gear box (Bearingless motor applications) can also be controlled. In applications where more system cooling

and flushing is required, a shuttle valve option is available in W series, 2000, 4000 Compact, 4000, 6000 series, VIS 30, VIS 40 and VIS 45 series motors.

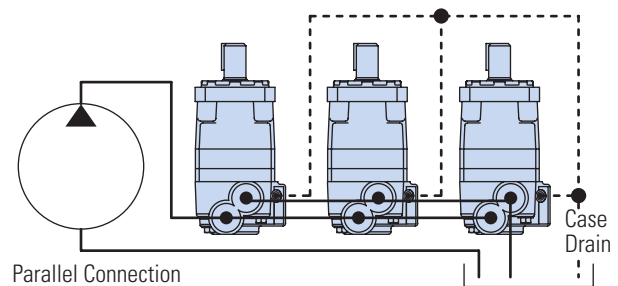
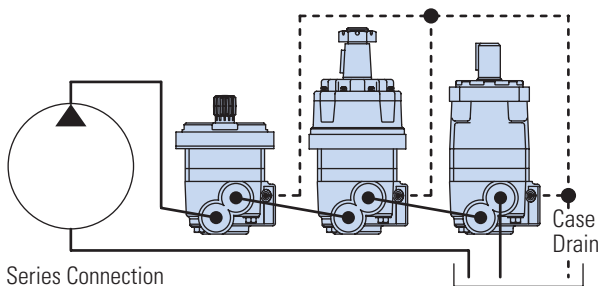



# Motor Application Information

## Vehicle Drive Calculations

### Step One – Calculate Motor Speed (RPM)

$$\text{RPM} = \frac{2.65 \times \text{KPH} \times G}{R_m} \quad \text{RPM} = \frac{168 \times \text{MPH} \times G}{R_i}$$

where KPH = vehicle speed (kilometers per hour)

where MPH = vehicle speed (miles per hour)

$R_m$  = rolling radius of tires (meter)

$R_i$  = rolling radius of tires (inch)

G = gear reduction ratio (if any) between motors and wheels. If no gear box or other gear reduction devices are used G = 1.

If vehicle speed is expressed in m/second, multiply by 3.6 to convert to KPH. If vehicle speed is expressed in ft./second, divide by 1.47 to convert to MPH.

### Step Two – Determine Rolling Resistance

Rolling resistance (RR) is the force required to propel a vehicle over a particular surface. The values in Table 1 are typical of various surfaces per 1000 lb. of vehicle weight.

$$\text{RR} = \text{GVW} \times \rho \text{ (kg) (lb)}$$

where GVW = gross (loaded) vehicle weight lb/Kg

$\rho$  = value from Table 1

**TABLE 1- ROLLING RESISTANCE COEFFICIENTS FOR RUBBER TIRES ON VARIOUS SURFACES**

Surface	r
Concrete, excellent	.010
Concrete, good	.015
Concrete, poor	.020
Asphalt, good	.012
Asphalt, fair	.017
Asphalt, poor	.022
Macadam, good	.015
Macadam, fair	.022
Macadam, poor	.037
Snow, 2 inch	.025
Snow, 4 inch	.037
Dirt, smooth	.025
Dirt, sandy	.040
Mud	.037 to .150
Sand, Gravel	.060 to .150
Sand, loose	.160 to .300

### Step Three – Tractive Effort to Ascend Grade

The largest grade a vehicle can ascend is called its "gradability." Grade is usually expressed as a percent rather than in degrees. A rise of one meter in ten meters or one footrise in ten feet of travel is a 1/10 or 10 percent grade.

$$\text{GR} = \text{GVW} (\sin \theta + \rho \cos \theta)$$

**TABLE 2**

Comparison Grade (%)	Table Slope (Degrees)
1%	0° 35'
2%	1° 9'
5%	2° 51'
6%	3° 26'
8%	4° 35'
10%	5° 43'
12%	6° 5'
15%	8° 31'
20%	11° 19'
25%	14° 3'
32%	18°
60%	31°

### Step Four – Determine Acceleration Force (FA)

The force (FA) required to accelerate from stop to maximum speed (KPH) or (MPH) in time (t) seconds can be obtained from the following equation:

$$\text{FA} = \frac{\text{KPH} \times \text{GVW}(\text{kg})}{3.6 t}$$

FA = Acceleration Force (Newton)  
t = Time (Seconds)

$$\text{FA} = \frac{\text{MPH} \times \text{GVW} (\text{lb})}{22 t}$$

FA = Acceleration Force (lb)  
t = Time (Seconds)

### Step Five – Determine Drawbar Pull

Drawbar Pull (DP) is total force available at the drawbar or "hitch" after the above forces have been subtracted from the total propelling force produced by the hydraulic motors. This value is established as either:

1. A goal or objective of the designer.
2. A force required to pull a trailer (Repeat steps two through four above using trailer weight and add the three forces together to obtain DP).

# Motor Application Information

## Vehicle Drive Calculations

### Step Six — Total Tractive Effort

The tractive effort (TE) is the total force required to propel the vehicle and is the sum of the forces determined in Steps 2 through 5.

$$TE = RR + GR + FA + DP \text{ (Kg. or lb.)}$$

$\swarrow$   $\swarrow$   $\swarrow$   $\swarrow$   
 Force required to overcome rolling resistance    Force required to climb a grade    Force required to accelerate    Drawbar pull desired

Wind resistance forces can usually be neglected. However, it may be wise to add 10% to the above total to allow for starting resistances caused by friction in bearings and other mechanical components.

### Step Seven — Calculate Hydraulic Motor Torque (T)

$$T = \frac{TE \times R_m}{N \times G \times E_g} \text{ (Nm / Motor)}$$

$$T = \frac{TE \times R_l}{N \times G \times E_g} \text{ (lb - in/Motor)}$$

Where: N = number of driving motors  
Eg = gear box mechanical efficiency

### Step Eight—Wheel Slip

If the torque required to slip the wheel (TS) is less than the torque calculated in Step 7, the performance objectives cannot be achieved.

$$TS = \frac{W \times f \times R_m}{G \times E_g} \text{ (Nm / Motor)}$$

$$TS = \frac{W \times f \times R_l}{G \times E_g} \text{ (lb - in/Motor)}$$

Where: f = coefficient of friction  
W = loaded vehicle weight over drive wheel

	Coefficient of friction (f)
Steel on steel	0.15 to 0.20
Rubber tire on dirt	0.5 to 0.7
Rubber tire on asphalt	0.8 to 1.0
Rubber tire on concrete	0.8 to 1.0
Rubber tire on grass	0.4

It may be desirable to allow the wheel to slip to prevent hydraulic system overheating when excessive loads are imposed should the vehicle stall. In this case TS should be just slightly larger than T.

### Step Nine — Motor Radial Load Carrying Capacity

When a motor is used to drive a vehicle with the wheel mounted directly on the motor shaft or rotating hub, the Total Radial Load (RL) acting on the motor shaft is the vector summation of two forces acting at right angles to each other.

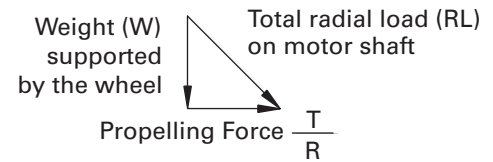

$$RL = \sqrt{W^2 + \left(\frac{T}{R}\right)^2}$$

Refer to radial load rating of each motor series.

### Shaft Torque (T)

$$T = \frac{q \times DP}{2 \times p}$$

$$\frac{\text{bar} \times \text{cm}^3/\text{rev}}{62.8} = \text{Nm}$$

$$\frac{\text{PSI} \times \text{in}^3/\text{rev}}{6.28} = \text{lb - in}$$

### Shaft Speed (N)

$$N = \frac{\text{Flow}}{\text{Displacement}}$$

$$\text{RPM} = \frac{1000 \times \text{l/min}}{\text{cm}^3/\text{rev}} \quad \text{RPM} = \frac{231 \times \text{GPM}}{\text{in}^3/\text{rev}}$$

### Power (into motor)

$$Kw = \frac{\text{bar} \times \text{l/min}}{600} \quad \text{HP} = \frac{\text{PSI} \times \text{GPM}}{1714}$$

### Power (out of motor)

$$Kw = \frac{\text{Nm} \times \text{RPM}}{9549} \quad \text{HP} = \frac{\text{lb - in} \times \text{RPM}}{63,025}$$

where: Kw = Kilowatt  
HP = Horsepower  
LPM = Liters per Minute  
GPM = Gallons per Minute  
Nm = Newton Meters  
lb-in = Pound inch  
Bar = 10 Newtons per Square Centimeter  
PSI = Pounds per Square Inch  
q = Displacement

# Optional Features

OPTIONAL FEATURE	BENEFIT
2 Speed motors	Allows motor to have two displacements (higher speed has lower torque)
Seal Guard	Prevents physical damage to shaft seal from foreign debris
High pressure Shaft Seal	More robust shaft seal that can withstand high case pressure spikes
Environmental protection	Epoxy coating for demanding application in harsh environment
Nickel Plated Shaft Nickel Plated Body	For highly corrosive environment or food/sanitary applications
Integrated Parking Brake	Spring applied hydraulic release brake
Mechanical Disc Brake	Bolt on caliper brake for wheel motor applications
Free running option	Improved mechanical efficiency at high-speed/high-flow conditions
Speed sensors	To collect speed and/or direction information from a motor and provide electric signal
Shuttle valve	Redirect some low pressure oil for increased cooling in closed loop applications
Case port	To increase lubrication and flushing of the motor and reduce case pressure , extend seal life
Internal check valves	Relieves the case pressure to the low pressure port
Low speed valving	For better efficiency and smooth running at low speed conditions (<200 RPM)
Vented Two-Stage seal	Extends shaft seal life
Viton seals	For higher temperature or chemical resistance applications
Integral cross over valving	Cost effective design that limits the differential pressure across the motor
Metric Shafts, Ports, & Mounts	EU specific threads
Reverse Rotation	Allows clockwise shaft rotation with B port pressurized
ATEX	Certifies motor to be used in explosive environments

### TYPICAL APPLICATIONS\*

OPTIONAL FEATURES	WINCH	SWING DRIVES	SWEEPER BRUSH DRIVES	AUGER	INDUSTRIAL CONVEYOR	CAR WASH	TURF PROPEL	IRRIGATION REELS	MIXERS/GRINDERS	PLASTIC INJECTION MOLDING	TRACTION DRIVES	TRENCHER CHAIN DRIVES	SALT SAND SPREADER	MARINE WINCHES
2 Speed Motors	x			x				x			x			x
Seal Guard			x				x		x			x		
Viton Seals					x					x				
High Pressure Shaft Seal	x								x					
Environmental protection					x	x							x	x
Nickel Plated Shaft					x	x							x	x
Nickel Plated Body					x									
Integrated Parking Brake	x	x			x			x			x			x
Mechanical Disc Brake							x				x			
Free running option		x												
Speed sensors					x			x	x	x		x	x	
Shuttle valve							x		x		x	x		
Case port	x	x	x	x	x		x		x		x	x		
Internal check valves					x	x	x							
Low speed valving		x			x		x				x		x	
Vented Two-Stage seal					x	x	x				x			
Integral cross over valving	x	x		x										x
Metric Shafts, Ports, & Mounts	x	x	x	x	x	x	x	x	x	x	x	x	x	x
Reverse Rotation					x									

\* These features are not limited to these applications. Final configuration depends on individual application needs.

# Optional Features

FEATURE DESCRIPTION	CATALOG PAGE NUMBER	SPOOL VALVE MOTORS					DISC VALVE MOTORS					VIS MOTORS	
		J Series	H Series	S Series	T Series	W series	2000 Series	4000 Compact Series	4000 Series	6000 Series	10000 Series	VIS 40	VIS 45
2 Speed motors	A-11	—	—	—	—	—	0	—	—	—	0	0	0
Seal Guard	A-12	—	0	0	0	—	0	0	0	0	0	0	0
Viton seals	A-12	0	0	0	0	0	0	0	0	0	0	0	0
High pressure Shaft Seal	A-13	—	0	0	0	—	0	0	—	—	—	—	—
Environmental protection	A-13	0	0	0	0	0	0	0	0	0	0	0	0
Nickel Plating Options	A-20	0	0	0	0	0	0	0	0	0	0	—	—
Integrated Parking Brake	A-14	—	—	—	0	0	—	—	—	—	—	0	0
Mechanical Disc Brake	A-14	—	—	—	—	0	0	0	—	—	—	—	—
Free running option	A-15	0	0	0	0	0	0	0	0	0	0	0	0
Speed sensors	A-16	0	0	0	0		0	0	0	0	0	—	—
Shuttle valve	A-17					0	0	0	0	0	—	0	0
Case port	A-18	0	0	0	0	0	S	S	S	S	S	S	S
Internal check valves	A-18	S	0	S	0	0	—	—	—	—	—	—	—
Low speed valving	A-19	—	0	0	0	S	—	—	—	—	—	—	—
Vented Two-Stage seal	A-20	—	0	0	0		—	—	—	—	—	—	—
Integral cross over valving	A-21	—	—	—	—		0	0	—	—		—	—
Metric Shafts, Ports, & Mounts	—	0	0	0	0	0	0	0	0	0	0	0	0
Reverse Rotation	—	0	0	0	0	0	0	0	0	0	0	0	0
ATEX Certification			0	0	0		0	0	0	0	0	0	0

0 Optional  
 S Standard  
 — Not applicable

# Two Speed Motors

This option is available on all 2000, 10,000, VIS 40 and VIS 45 motors.

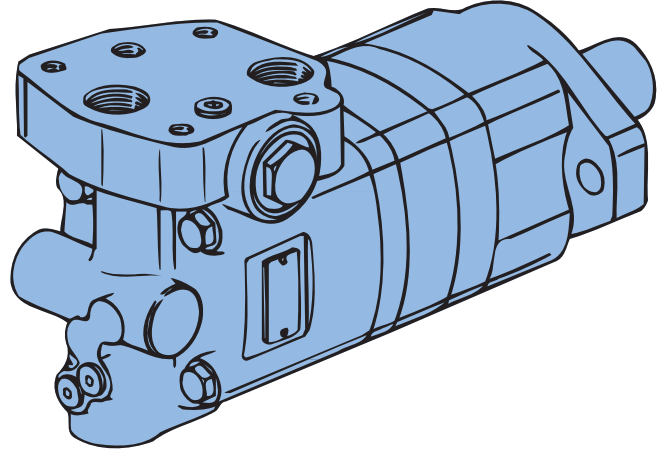

### Features:

This option gives the user the ability to switch the displacement of the motor thus providing a different speed at a different torque without changing the input flow or pressure. An external three way valve is required for shifting the pilot pressure port between signal pressure (HSLT) and low pressure (LSHT).

Two speed motors are available with a return line closed center shuttle for closed circuit applications.

### Benefits:

- Two operating speeds and torque levels with one motor
- Two selectable performance ranges in one motor package

### Application:

- Conveyors
- Winches
- Traction drives
- Augers
- Irrigation/utility cable reels

# Seal Guard

This option is available on H, S, T, 2000, 4000, 6000, 10,000, VIS 40 and VIS 45 series motors

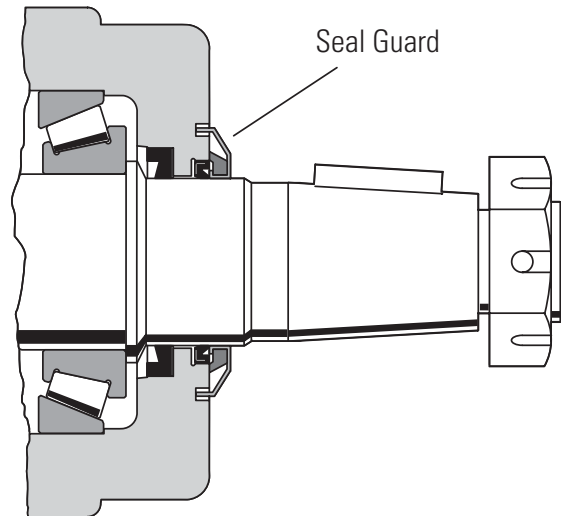

## Features:

This option consists of a metal shield that protects an internal wiper seal. The shield is interference-fit on the output shaft and moves with the output shaft. For added protection, the shield is recessed into a groove in the bearing housing face.

## Benefits:

Centrifugal force causes foreign debris to be forced away from the high pressure shaft and dust seal area. The seal does not seal hydraulic fluid, instead it protects the standard seals from damage caused by foreign debris.

## Applications:

- Street sweepers
- Industrial sweepers
- Lawn and turf equipment (ZTR)
- Harvesting machinery
- Mining equipment

# Viton Seals

This option is available on all Char-Lynn motors.

## Features:

Higher chemical compatibility and temperature tolerance make Viton the material of choice for demanding application in extremely corrosive and harsh environments.

## Benefits:

- Longer seal life in chemically aggressive environment
- Operating Temperature Range of -25°C to 200°C [-13°F to 392°F]

## Applications:

- Industrial conveyors
- Plastic injection molding

**Note:** Minimum Viscosity Levels must still be maintained

# High Pressure Seals

This option is available on H, S, T and 2000 series motors.

## Features:

Eaton has introduced a high-pressure shaft seal option for its H, S, T and 2000 series motors. The seal geometry is optimized for applications that operate under extreme conditions. The seal geometry increases the clamping force of the sealing lip against the output shaft to prevent seal leakage at extreme pressure conditions. Case pressure forces the lip of the seal to clamp more tightly against the output shaft. The result is a seal that handles high pressure spike conditions without failure. The seal is designed to withstand case pressures up to 200 bar [2900 PSI] at 150 rpm.

For reference, the standard seal can withstand case pressure up to:

- 100 bars (1500 PSI) for H, S, T motors
- 140 bars (2000PSI) for 2000 Series
- 100 bars (1500 PSI) for 4000 Series
- 70 bars (1000 PSI) for 6000 Series
- 20 bars (300 PSI) for the 10,000 Series
- 20 bars (300 PSI) for VIS 40, 45

## Benefits:

- Increases ability to handle high-pressure spike conditions.
- Eliminates the use of case port line in application with intermittent extreme operating conditions.
- Can be an effective alternative to additional case port plumbing.
- Operating Temperature -40°C to 150°C [-40°F to 300°F]

## Special Notes:

1. Intermittent operation is defined as 10% of every minute.
2. The standard seal with case port option is preferred for maximum life – especially for continuous duty at high pressure conditions.
3. Seal kits are available to convert motors with the standard shaft seal to the high pressure shaft seal. (complete motor seal kits include high pressure shaft seal).
4. Minimum Viscosity Levels must be maintained.

## Applications:

- Harvesters
- Sweepers
- Turf Equipment
- Wood Chippers
- Stump Grinders
- Skid Steer Loader Attachments (often loaders have no case line available)
- Any application with extreme intermittent operating conditions or where no case return line is available.

## Part Numbers:

H Series – Kit No. 60572-000

S Series – Kit No. 60578-000

T Series – Kit No. 60579-000

Shaft Seal – Part No. 14778-001

2000 Series – Kit No. 61329-000.

Shaft Seal – No. 14857-001



# Brake Solutions

Integrated brake options are available for all T, W, and VIS 40 series motors. Mechanical bolt-on packages are available for all W, 2000 and 4000 Compact series motors.

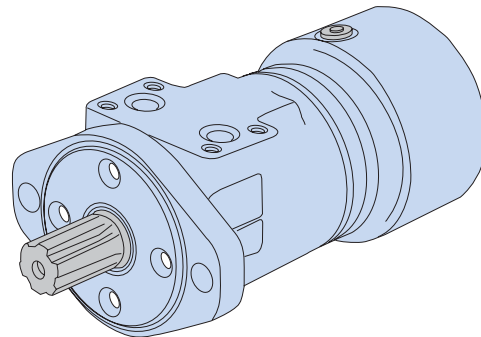
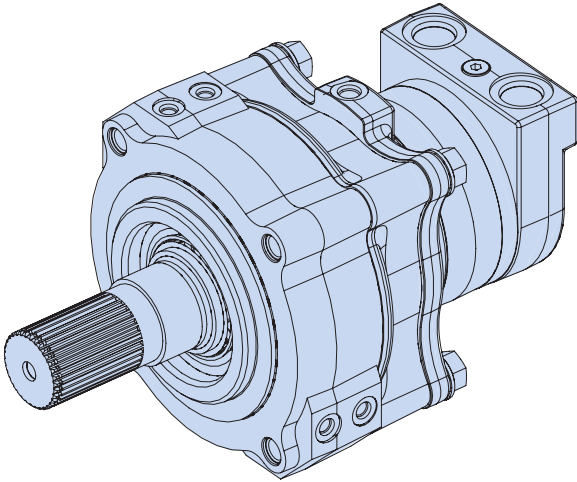

## Features:

Eaton continues to develop and bring new brake solutions to market that are performance matched to each motor series. These include:

- T Series with Integrated Parking Brake
- W Series with Integrated Parking Brake
- VIS Series with Integrated Parking Brake

In addition, Eaton brake motors can be mated with bolt-on valve packages to provide dynamic braking hydraulically using state of the art counter-balance valve technology.

There are also a variety of bolt-on mechanical brake options including Hayes brake system. This compact brake package can be used on 2000 Series and W Series wheel motors.

## Benefits:

- Complete compact system package
- Performance-matched brake / motor solution
- Increases design flexibility
- Reduces assembly costs and simplifies service requirements
- Streamlines inventory and order processing.
- Ability to direct port release pressure (eliminate brake release hose correction)

## Applications:

- Aerial Work Platforms
- Boom Lifts
- Track Cranes
- Forestry Grapples
- Winches
- Traction Drives
- Anywhere load holding is a requirement in a LSHT motor application

# Free Running Geroler Sets/Gerotor Sets

This feature is available in all Char-Lynn motors.

## Features:

The free running option is accomplished using a specially precision-machined gerotor/geroler assembly. This feature increases the clearance between the star and mating ring, allowing the motor to turn more freely with less mechanical drag. The increased clearance also improves lubrication across the wear surfaces of the gerotor star and ring and provides a

greater pressure-relieving flow path reducing pressure spikes. Flow is by-passed internally across the star tips, reducing shock loads to the main drive components. This feature provides an effective method for reducing shock loads to the main drive components.

## Benefits:

- Suited for applications with rapid stop/start or rapid reversals.

- Reduces starting pressure and increases starting torque efficiency.
- Reduces pressure spikes through the orbit gear set.

## Applications:

- Harvesters
- Stump Grinders
- Skid Steer Loader Attachments
- Machine Tools
- Especially suited for continuous high speed/high flow applications.

- Also suited for applications with high-pressure spikes from rapid reversals.

## Special Notes:

Volumetric Efficiency will be reduced with the free-running option.

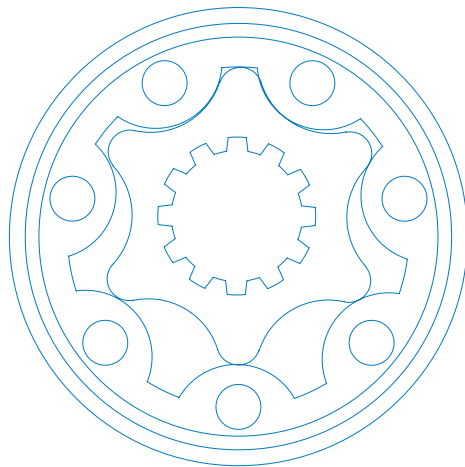

Gerotor

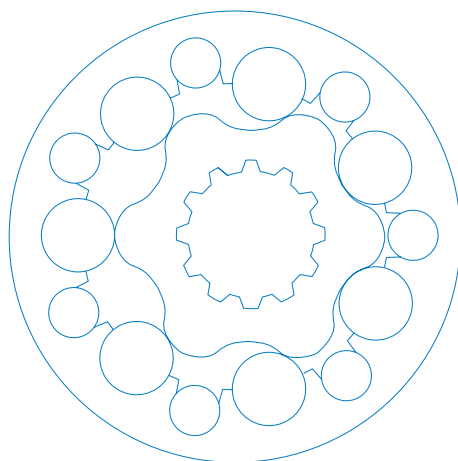

Geroler

## Gerotor or Geroler?

The H series motor uses a Gerotor while the rest of the Char-Lynn motors use a Geroler. The difference is shown in the picture below:

Essentially a Geroler, has rolls added to the lobes of the outer ring of the Orbit gear set. These rolls act as a roller bearing and reduce friction, increase mechanical efficiency and reduce wear in systems with low fluid viscosity. In addition, the Geroler type typically provides smoother performance at low speed conditions. The basic formula and guideline to determine whether a gerotor or Geroler should be used is as follows:

**20 x psi / RPM = SUS** (use this formula to determine minimum fluid viscosity)

RPM = speed of output shaft in revolutions per minute

SUS = minimum viscosity measured in SUS.

The recommended viscosity limits are as follows:

- 1) A Gerotor Orbit gear set requires a minimum fluid viscosity of 100 SUS or the value calculated by the formula  $20 \text{ psi/RPM} = \text{SUS}$ .
- 2) A Geroler Orbit gear set requires a minimum fluid viscosity of 70 SUS.

In addition, applications running at less than 100 rpm should consider using a Geroler motor.

# Speed Sensors

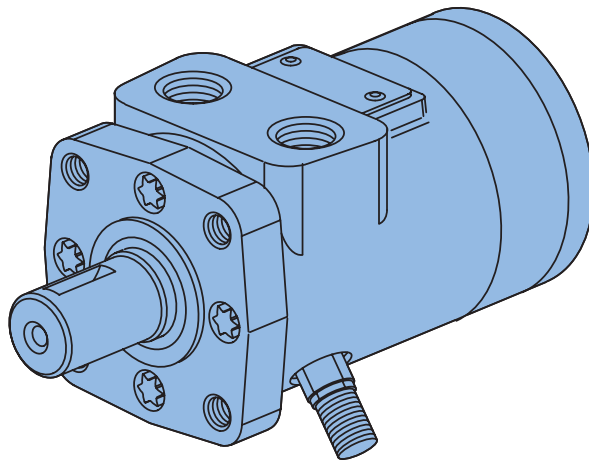

## Note:

The speed sensor option does NOT include read-out display. Possible sources for read-out display include:

Eaton Corporation Durant Products 901 South 12 Street Watertown, WI 57094 — Phone 1-800-289-3866.

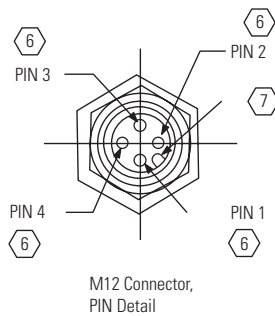

## Features:

Eaton has developed speed sensors specifically designed for LSHT motors.

### The single output speed sensor:

This design is rugged and fully protected against accidental reverse polarity or short circuit hook up. A built in pull up resistor simplifies installation with control systems. This sensor is fully compatible with the mobile vehicle electrical systems and gives a reliable digital on/off signal over a wide speed range and temperature range. The sensor is field-serviceable; no factory setting or shimming is required.

### The dual output speed sensor:

This sensor provides both speed and direction information. Its design is based on the field proven technology of our standard sensor and is designed for off road environments. The new sensor is based on the principle of quadrature.

- The first version speed sensor has two output signals 90° out of phase. Each output provides one pulse per target.
- The second version has a speed signal that is twice the output pulses per revolution and it also has a direction signal. (Direction not available on spool motors)

## Benefits:

These speed sensors provide vital information that can be collected and interpreted by a PLC or other device.

## Applications:

- Salt/Sand Spreaders
- Irrigation Drives
- Machine Tools
- Mixers/Grinders
- Industrial Conveyors
- Food Processing Equipment
- Underground Boring Equipment

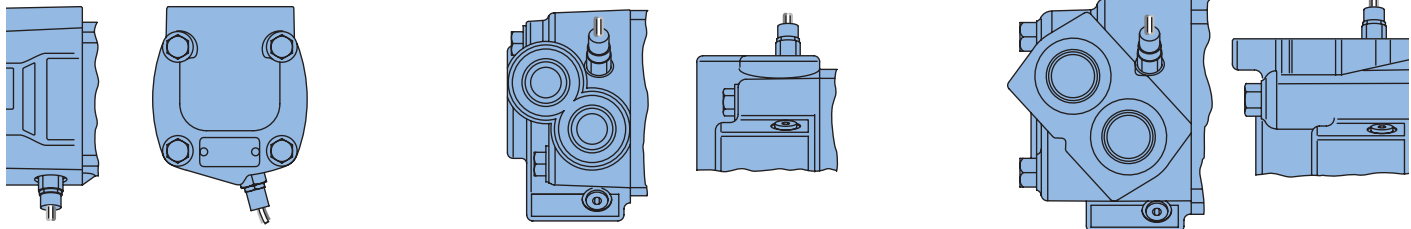

## TECHNICAL INFORMATION

Motors	Speed Sensor Pulses Per Rev	Quadrature Pulses Per Rev
J,H,S,T,W	15	60
2000 series	30	60
4000 series	30	72
6000 series	30	80
10,000 series	30	60

### Single and Two Outputs:

Supply Voltage: 8 to 24 Vdc (compatible with 12V vehicle systems)

Supply Current: 20 mA max. (Vs) (including internal pull-up resistor)

Output Voltage: Low < .5 Vdc @ 10 mA; output is open collector with 10kΩ pull-up resistor

### M12 Connector (version 1)

- Pin 1 = Power supply
- Pin 2 = Output one
- Pin 3 = Common
- Pin 4 = Output two

### M12 Connector (version 2)

- Pin 1 = Power Supply
- Pin 2 = Direction
- Pin 3 = Common
- Pin 4 = Speed signal

# Shuttle Valve

## Lubricating Shuttle

The shuttle valve option is available in W, 2000, 4000, 6000, and VIS series motors.

## Features

Case Port allows for hydraulic oil to be flushed and cools the system. In applications where more system cooling and flushing is required.

## Benefits

- Flushing
- Cooling
- Longer system life

## Applications

- Turf Propel
- Mixers/Grinders
- Traction drives
- Trencher chain drives

## Closed Loop Circuit

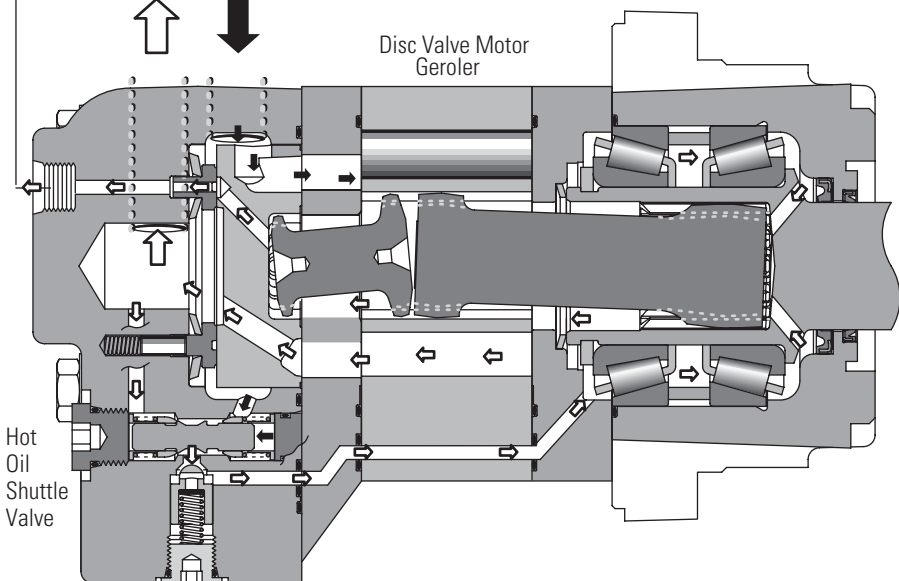
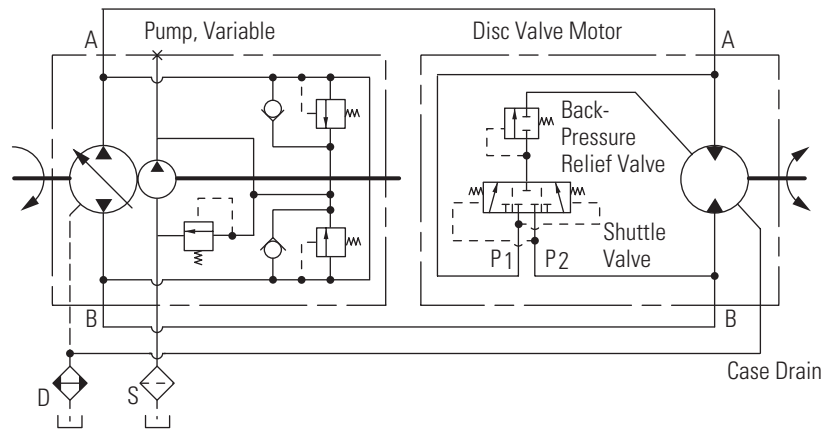
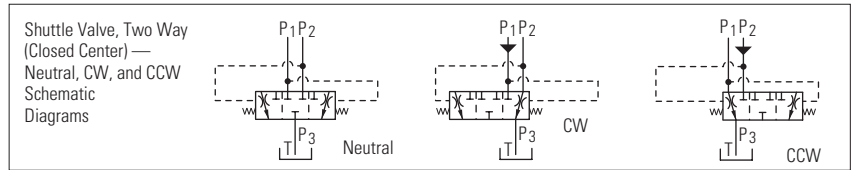
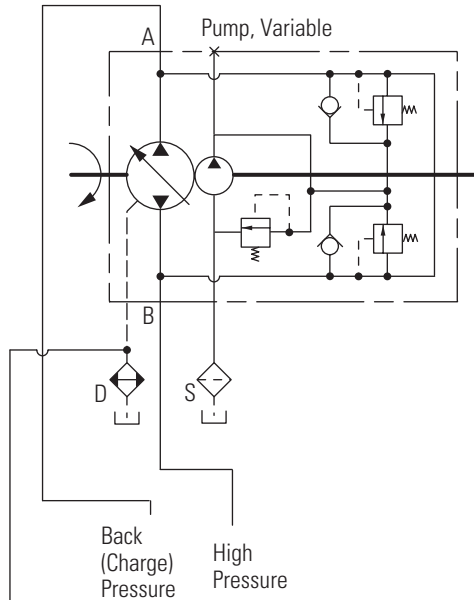

Closed Loop Back-Pressure (Charge) Relief Valve

Motors with shuttle valve must have a case port to tank, without this port line the internal drive splines will not have adequate lubrication.

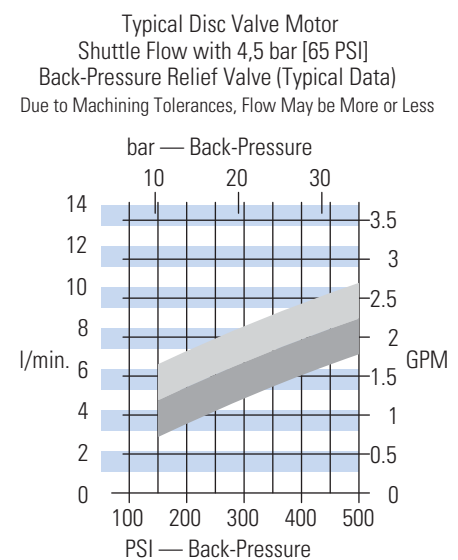

- 4000 Series and 6000 Series
- 2000 Series and 4000 Compact Series

# Case Porting

This option is available on all Char-Lynn Motors.

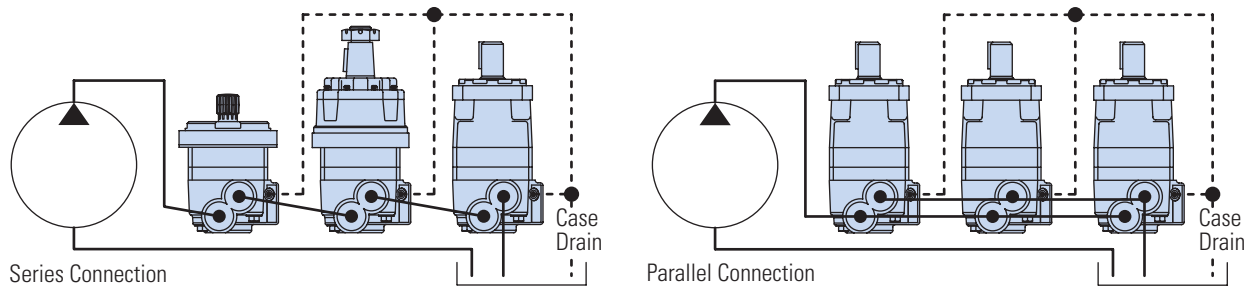

## Features:

This feature provides for connection of a port line connected to the motor case.

A port is located in the motor direct to motor case pressure that allows the case pressure to be returned directly to tank. Internal leakage to the motor case cavity can be drained directly which reduces case pressure and provides flushing of the system circuit.

## Benefits:

- Extends shaft seal life
- Extends thrust bearing life
- Reduces shaft seal leakage problems
- Improves flushing of the circuit to reduce system contaminates and cooling the system.

## Applications:

- Especially suited for continuous running industrial applications and where motors are operating under high back pressure conditions (e.g. series circuit applications).
- Conveyers
- Car wash
- Harvesters
- Recommended for applications running with high case pressure conditions

# Low Speed Valving

This option is available on H, S, T and W series motors.

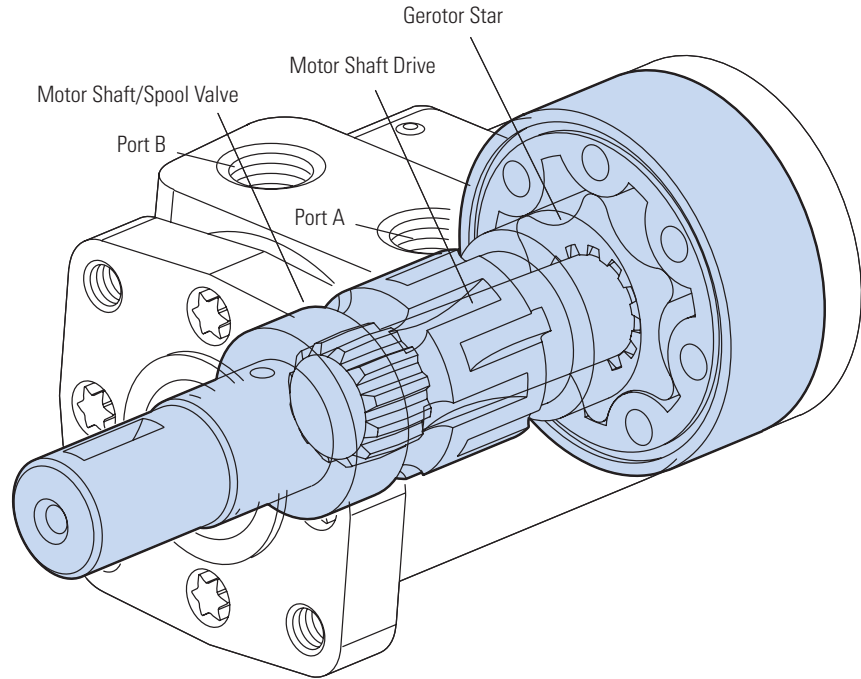

## Features:

This feature optimizes the motor for low-speed performance. It greatly improves smooth operation at speeds below 200 rpm. The valving is optimized with increased sealing and tighter clearances. Motors with this feature are designed to run continuously up to 200 rpm at standard rated pressures.

## Benefits:

- Improves smoothness at low speed conditions (less than 200 rpm)
- Improves volumetric efficiency

## Applications:

- Salt-sand spreaders
- Machine tools
- Irrigation drives
- Consider for applications running at low speed conditions below 200 rpm.

## Notes:

Motors with this valving are not intended for low pressure applications (A minimum of 300 psi delta must be maintained between A port pressure and case pressure)

# Nickel Plating Options

## Full Body Nickel Plating

This option is available on H, S, T, 2K, 4K, 6K motors.

### Features:

Eaton is offering full body nickel plating for Char Lynn Motors for protection against wash down environments (Note: this does not offer protection against salt water environments and the recommended option for that is epoxy paint). In order to meet the different requirements, Eaton is now offering two different nickel plating options shown below:

### Benefits:

- Protection in heavy and frequent washdown environments
- Single source plating at a competitive prices
- Warranty from Eaton on nickel plating

### Applications:

- Food Processing: Industrial Conveyors

### Choosing the options in the model code:

- H, S, T Motors - Choose Option Y in Paint / Packaging Options
- 2000, 4000, 6000 Series - Choose Option

OPTION	DESCRIPTION	APPLICATIONS
Electroless Nickel Plating (AMS 2404D specification)	Premium process offering extremely high quality corrosion resistance	Where water contact is extremely high <sup>+</sup>
Electrolytic Nickel Plating (AMS-QQ-N-290 specification)	Good quality process offering standard corrosion resistance	Where water contact is minimal <sup>+</sup>

+ Washdown applications only – does not include salt water applications

## Nickel Plated Shafts

This option is available on H, S, T, motors.

### Features:

Eaton is offering Electroless nickel plating on the shafts alone for corrosion protection primarily in wash down environments.

### Benefits:

- Protection in heavy and frequent washdown environments
- Single source plating at a competitive prices
- Warranty from Eaton on nickel plating

### Applications:

- Car Washes
- Fishing Winches / Marine applications

## Environmental Protection

(epoxy paint)  
(plated shafts)

This option is available on all Char-Lynn motors.

### Features:

All motors are available with a corrosion resistant coating for use in hostile environments. The Char-Lynn line is also available with the output shaft plated, or with plated shaft and entire motor exterior coating.

### Benefits:

This coating protects the motor from salt water and various chemicals.  
Motor output shaft plating helps eliminate seal damage caused by caustic or acidic materials.

### Applications:

- Marine
- Food processing,
- Cleansing
- Fishing and agricultural applications

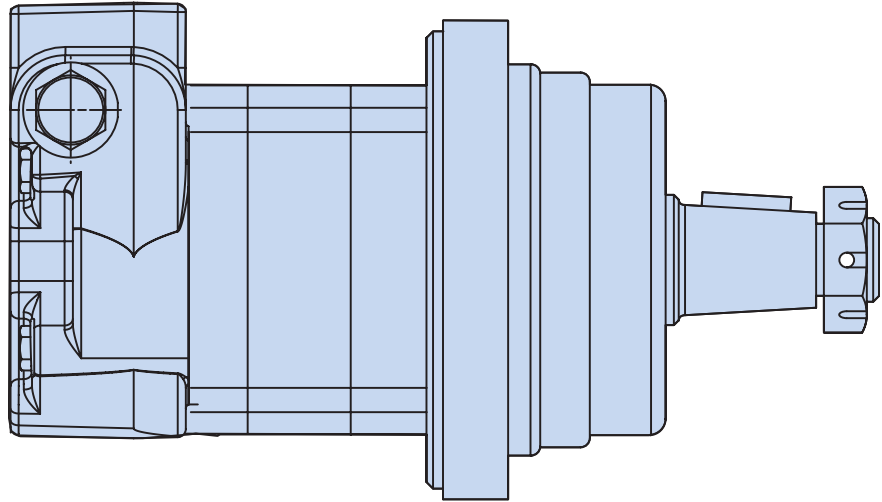

**Features:**

- Complete packaged system solution, single source for motors with relief valve capability
- Relief valves as close to Geroler as possible, providing added protection
- Eliminate leak points from in-line or bolt-on relief's
- Valves capable of full motor pressure
- Provides added flexibility to system design by allowing motors to have individual relief valve settings
- Simplifies assembly, purchasing and system design requirements

**Benefits:**

- This compact and efficient package offers increased value and cost effectiveness to designing Eaton into your applications.
- Minimizing the use of hoses, tubing and fittings will reduce production and assembly time significantly.

**Applications:**

- Skid-steer attachments
- Swing motors
- Brush cutters & Mowers
- Harvesting equipment
- Directional boring
- Winch
- Auger

Any place where pressure relief is optimal for system or motor performance and life

Replacement cartridges can be obtained by ordering the Item part number as listed below.

**REPLACEMENT CARTRIDGES**

Item part #	Item desc.	Relief valve setting
02-199291	RV5A-10-F-0-35/15	1500 PSI
02-199292	RV5A-10-F-0-35/17.5	1750 PSI
02-199293	RV5A-10-F-0-35/20	2000 PSI
02-199295	RV5A-10-F-0-35/22.5	2250 PSI
02-198563	RV5A-10-F-0-35/25	2500 PSI
02-199294	RV5A-10-F-0-35/27.5	2750 PSI
02-199296	RV5A-10-F-0-35/30	3000 PSI



# Special Housings Bolt on Solutions

Cartridge Valves & Manifolds for Spool & Disk Valve Motors

## We Manufacture Solutions

Designing hydraulic systems with Eaton-Vickers Cartridge Valves & Manifolds is a cost effective way of bringing your design into production well within the most demanding of production schedules. Minimizing the use of hoses, tubing and fittings will reduce production and assembly time significantly.

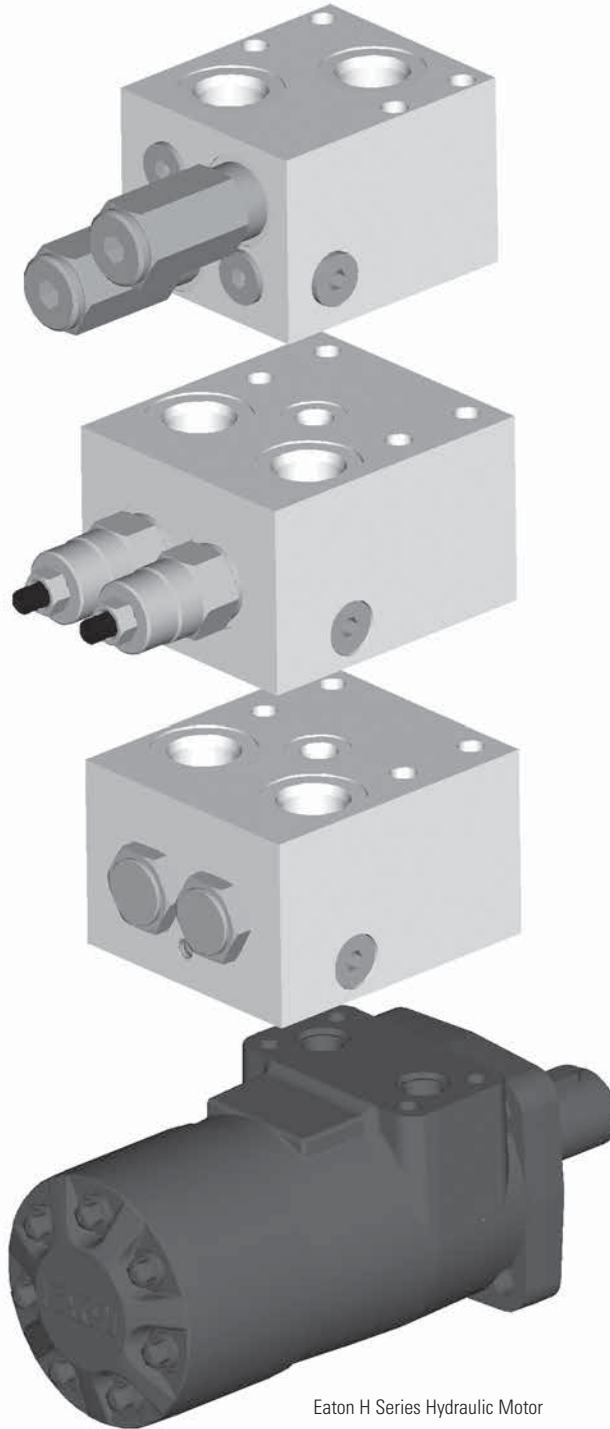

Eaton H Series Hydraulic Motor

## Features

- Compatible with Eaton H & T series spool valve motors, and most 2000 series disk valve motors
- Aluminum Manifolds Anodized Black
- Pre-set cartridges to your specifications
- 100% production tested assembly
- Wide range of settings available
- Intelligent model code
- Manifolds are available with out cartridge valves, or pre-assembled and tested to your specifications
- Manifolds and motors can be supplied as a pre-assembled package
- Dual counterbalance valve (with integral shuttle valve), dual pilot operated check valve and dual cross port relief valve packages are available

# ICEHT35/ICEEHT35 - Motor Mounted Valves

## H & T Mounting Pattern Single and Dual Overcenter Valves

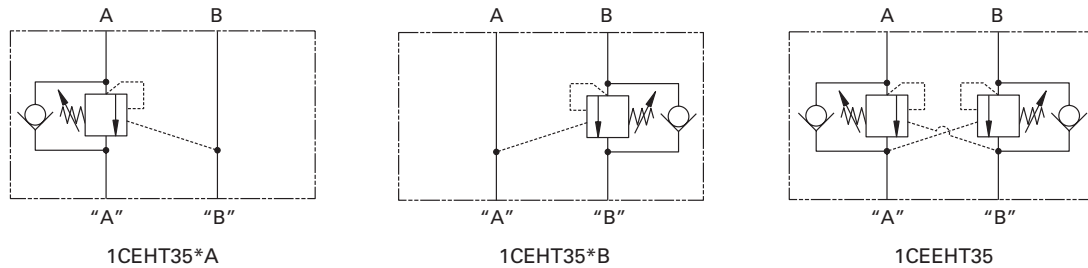

### Description

Overcenter valves give static and dynamic control of loads by regulating the flow into and out of hydraulic actuators. When installed close to or within an actuator, the overcenter valve will stop runaway in the event of hose burst and if open center directional control valves are used, will allow thermal expansion relief of the hydraulic fluid. The overcenter cartridge is ideal for mounting directly into a cavity machined in the body of the cylinder, motor or rotary actuator.

The cartridge can also be mounted directly to the ports via a specifically machined body as part of a Hydraulic Integrated Circuit or single unit, or contained within one of our standard line bodies.

Single overcenter valves are normally used when the load is unidirectional, for example an aerial platform or crane and dual overcenter valves are used for controlling loads in both directional for motor applications or for cylinders going over center.

### Operation

The check section allows free flow into the actuator then holds and locks the load against movement. The pilot assisted relief valve section will give controlled movement when pilot pressure is applied. The relief section is normally set to open at a pressure at least 1.3 times the maximum load induced pressure but the pressure required to open the valve and allow movement depends on the pilot ratio of the valve. For optimization of load control and energy usage, a choice of pilot ratios is available.

The pressure required to open the valve and start actuator movement can be calculated as follows:

$$\text{Pilot Pressure} = \frac{(\text{Relief Setting}) - (\text{Load Pressure})}{\text{Pilot Ratio}}$$

### Pilot Ratios

- 2.5:1 Best suited for extremely unstable applications such as long booms or flexible frameworks.
- 5:1 Best suited for applications where load varies (Standard) and machine structure can induce instability
- 10:1 Best suited for applications where the load remains relatively constant.

### Performance Data

#### Ratings and Specifications

Figures based on: Oil Temp = 40°C Viscosity = 32 cSt (150 SUS)

Rated flow	30 L/min (8 USgpm)		
Max setting	Max load induced		
	Pressure:	270 bar (4000 psi)	
	Relief setting:	350 bar (5000 psi)	
Cartridge material	Working parts hardened & ground steel External surface zinc plated		
Body material	Standard aluminium (up to 210 bar*) Steel (up to 350 bar)		
Mounting position	Unrestricted		
Cavity Number	A6610 (See section M)		
Torque cartridge into cavity	45 Nm (33 lbs ft)		
Weight	1CEOMP35	1.6 kg	(3.52 lbs)
(inc cartridges)	1CEEOMP35	1.66 kg	(3.65 lbs)
Seal kit number	1CEHT35	9900834-000 (Buna-N)	9900835-000 (Viton)
	1CEEHT35	9900836-000 (Buna-N)	9900837-000 (Viton)
Recommended filtration level	BS5540/4 Class 18/13 (25 micron nominal)		
Operating Temp	-30°C to +90°C (-22° to 194°F)		
Leakage	0.3 milliL/min nominal (5 dpm)		
Nominal viscosity range	5 to 500 cSt		
Installation Kit (includes cap screws, washers, and o-rings)	9900828-000 (Buna-N) 9900829-000 (Viton)		

# ICEHT35/ICEHT35 - Motor Mounted Valves

H & T Mounting Pattern Single and Dual Overcenter Valves

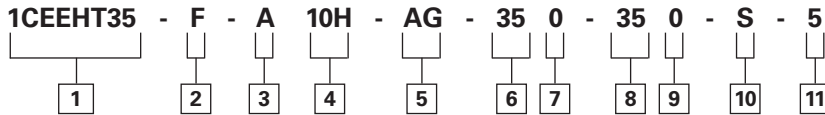
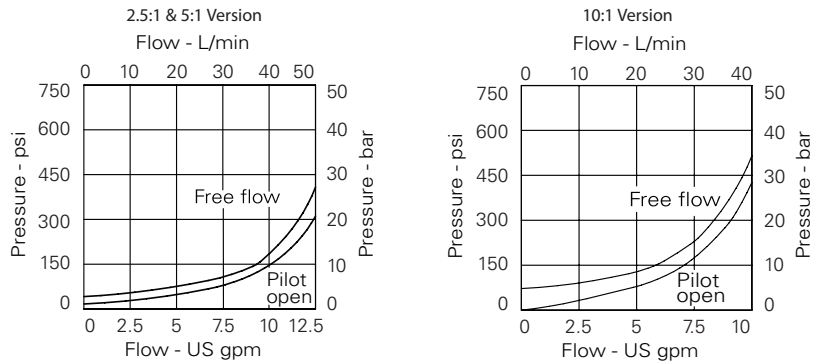

## 1 Basic Code

1CEEHT35 - Double Cartridge and Body  
 1CEEHT35\*A - Single overcenter in line A-"A"  
 1CEEHT35\*B - Single overcenter in line B-"B"

## 2 Adjustment Means

F - Screw Adjustment

## 3 Housing Material

A - Aluminum  
 S - Steel

## 4

Code	Port Size "A" & "B"	Dual Housing Number	
		Aluminum	Steel
4W	1/2" BSP	6024221-001	6024221-003
10H	SAE 10	6024221-002	
10T	SAE 10		6024221-04

## 5 Port Acted Upon

A - A Port  
 B - B Port  
 AB - A & B Ports (dual)

## 6 Pressure Range (Cart A)

Note: Code Based on pressure in bar.

20 - (2.5:1 and 5:1): 70-210 bar. Std setting 100 bar.  
 (10:1): 100-210 bar. Std setting 100 bar.

35 - (2.5:1 and 5:1): 100-350 bar. Std setting 210 bar.  
 (10:1): 120-350 bar. Std setting 210 bar.

## 7 Pressure Setting (Cart A)

0 - Std factory setting  
 1500 - 1500 psi

## 8 Pressure Range (Cart B)

Note: Code Based on pressure in bar.

20 - (2.5:1 and 5:1): 70-210 bar. Std setting 100 bar.  
 (10:1): 100-210 bar. Std setting 100 bar.

35 - (2.5:1 and 5:1): 100-350 bar. Std setting 210 bar.  
 (10:1): 120-350 bar. Std setting 210 bar.

## 9 Pressure Setting (Cart B)

0 - Std factory setting  
 1500 - 1500 psi

## 10 Seals

S - Buna-N  
 SV - Viton

## 11 Pilot Ratio

2 - 2.5:1  
 5 - 5:1  
 10 - 10:1

Cavity plug part number

Nitrile - AXP13032-01-N  
 Viton - AXP13032-01-V

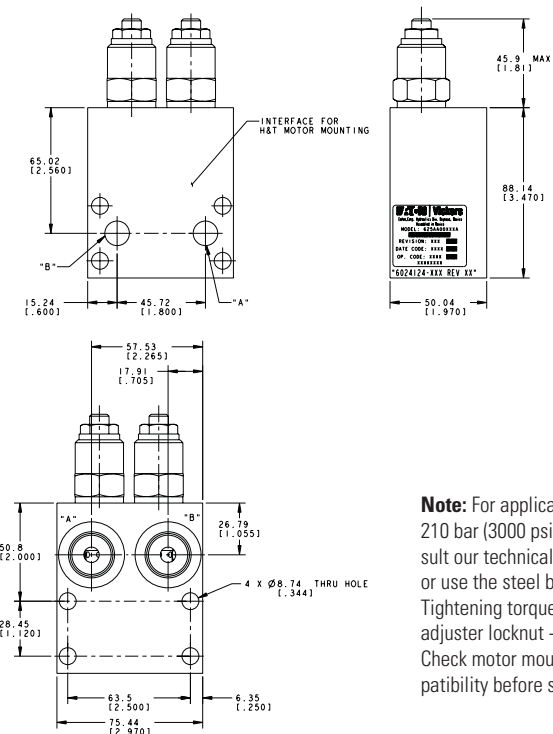

**Note:** For applications over 210 bar (3000 psi), please consult our technical department or use the steel body option. Tightening torque of "E" adjuster locknut - 20 to 25 Nm. Check motor mounting compatibility before specifying.

# ICESHHT35/ICEESHHT35 - Motor Mounted Valves

H & T Mounting Pattern Single and Dual Overcenter Valve with Brake Release Shuttle

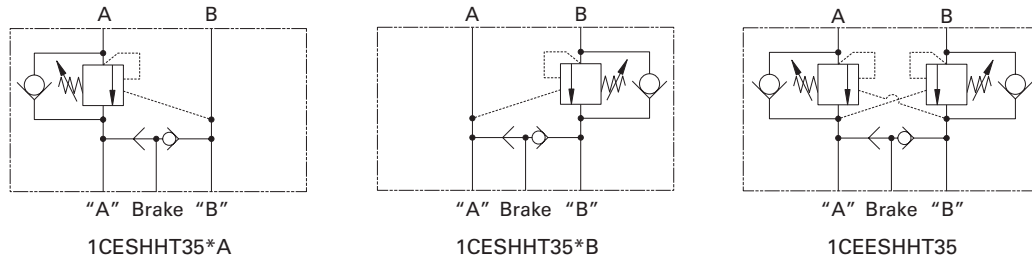

## Description

Overcenter Valves give static and dynamic control of loads by regulating the flow into and out of hydraulic actuators. When installed close to or within an actuator, the overcenter valve will stop runaway in the event of hose burst and if open center directional control valves are used, will allow thermal expansion relief of the hydraulic fluid.

These dual overcenter valves also contain a brake release shuttle valve which ensures that pressure is applied to a brake release circuit regardless of whether pressure is applied to ports "A" or "B". These multifunction valves are normally used for the static and dynamic control of systems using motors or semi-rotary-actuators.

## Operation

The check section allows free flow into the actuator then holds and locks the load against movement. The pilot assisted relief valve section will give controlled movement when pilot pressure is applied. The relief section is normally set to open at a pressure at least 1.3 times the maximum load induced pressure but the pressure required to open the valve and allow movement depends on the pilot ratio of the valve. For optimization of load control and energy usage, a choice of pilot ratios is available.

The pressure required to open the valve and start actuator movement can be calculated as follows:

$$\text{Pilot Pressure} = \frac{(\text{Relief Setting}) - (\text{Load Pressure})}{\text{Pilot Ratio}}$$

## Pilot Ratios

- 2.5:1 Best suited for extremely unstable applications such as long booms or flexible frameworks.
- 5:1 Best suited for applications where load varies (Standard) and machine structure can induce instability
- 10:1 Best suited for applications where the load remains relatively constant.

## Performance Data

### Ratings and Specifications

Figures based on: Oil Temp = 40°C Viscosity = 32 cSt (150 SUS)

Rated flow	30 L/min (8 USgpm)		
Max setting	Max load induced		
	Pressure:	270 bar (4000 psi)	
	Relief setting:	350 bar (5000 psi)	
Cartridge material	Working parts hardened & ground steel External surface zinc plated		
Body material	Standard aluminium (up to 210 bar*) Steel (up to 350 bar)		
Mounting position	Unrestricted		
Cavity Number	A6610 (See section M)		
Torque cartridge into cavity	45 Nm (33 lbs ft)		
Weight	1CESHHT35	2.29 kg	(5.04 lbs)
(inc cartridges)	1CEESHHT35	2.34 kg	(5.15 lbs)
Seal kit number	1CESHHT35	9900834-000 (Buna-N)	9900835-000 (Viton)
	1CEESHHT35	9900836-000 (Buna-N)	9900837-000 (Viton)
Recommended filtration level	BS5540/4 Class 18/13 (25 micron nominal)		
Operating Temp	-30°C to +90°C (-22° to 194°F)		
Leakage	0.3 milliL/min nominal (5 dpm)		
Nominal viscosity range	5 to 500 cSt		
Installation Kit (includes cap screws, washers, and o-rings)	9900828-000 (Buna-N) 9900829-000 (Viton)		

# ICESHHT35/1CEESHHT35 - Motor Mounted Valves

H & T Mounting Pattern Single and Dual Overcenter Valve with Brake Release Shuttle

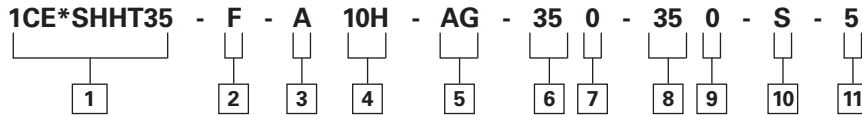
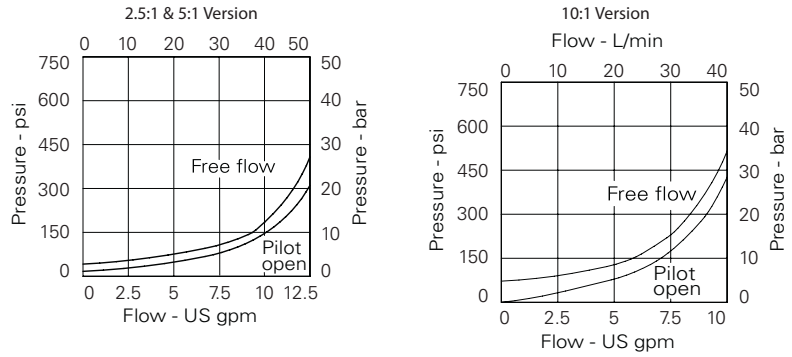

## 1 Basic Code

1CEESHHT35 – Double Cartridge and Body  
 1CESHHT35\*A – Single overcenter in line A-“A”  
 1CESHHT35\*B – Single overcenter in line B-“B”

## 2 Adjustment Means

F – Screw Adjustment

## 3 Housing Material

A – Aluminum  
 S – Steel

## 4

Code	Port Size		Dual Housing Number	
	“A” & “B”	Brake	Aluminum	Steel
4W	1/2” BSP	1/4” BSP	6025216-001	6025216-003
10H	SAE 10	SAE 4	6025216-002	
10T	SAE 10	SAE 4		6025216-004

## 5 Port Acted Upon

A – A Port  
 B – B Port  
 AB – A & B Ports (dual)

## 6 Pressure Range (Cart A)

Note: Code Based on pressure in bar.

20 – (2.5:1 and 5:1): 70-210 bar. Std setting 100 bar.  
 (10:1): 100-210 bar. Std setting 100 bar.

35 – (2.5:1 and 5:1): 100-350 bar. Std setting 210 bar.  
 (10:1): 120-350 bar. Std setting 210 bar.

## 7 Pressure Setting (Cart A)

0 – Std factory setting  
 1500 – 1500 psi

## 8 Pressure Range (Cart B)

Note: Code Based on pressure in bar.

20 – (2.5:1 and 5:1): 70-210 bar. Std setting 100 bar.  
 (10:1): 100-210 bar. Std setting 100 bar.

35 – (2.5:1 and 5:1): 100-350 bar. Std setting 210 bar.  
 (10:1): 120-350 bar. Std setting 210 bar.

## 9 Pressure Setting (Cart B)

0 – Std factory setting  
 1500 – 1500 psi

## 10 Seals

S – Buna-N  
 SV – Viton

## 11 Pilot Ratio

2 – 2.5:1  
 5 – 5:1  
 10 – 10:1

Cavity plug part number

Nitrile - AXP13032-01-N  
 Viton - AXP13032-01-V

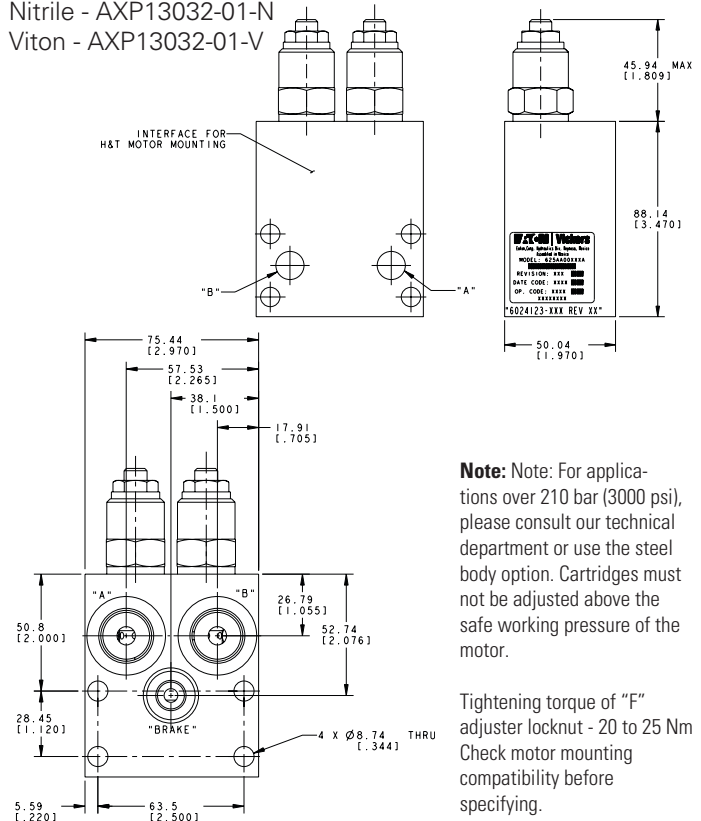

**Note:** Note: For applications over 210 bar (3000 psi), please consult our technical department or use the steel body option. Cartridges should not be adjusted above the safe working pressure of the motor.

Tightening torque of “F” adjuster locknut - 20 to 25 Nm  
 Check motor mounting compatibility before specifying.

# Dual Cross-over Relief Package for H&T Series Motors

Cartridge valves & manifolds for spool valve motors

## Dual Crossover Relief Valve Assembly

This valve assembly provides motor over-pressure protection in both directions of rotation, while supplying the return or lower pressure side of the motor with makeup oil. If closed center valving is used, an additional function is controlled braking.

Typical applications are vehicle propulsion and motor work circuits in which pressure limiting is required.

## How to Order

Complete pre-assembled packages are specified using the RV3A-10 model code. Option "A" must be selected for the cage seals,

position 6 of the model code is "H". To order the manifold separately, without the two RV3A cartridges, order the part number 4997062-001.

## RATINGS AND SPECIFICATIONS

Rated flow	76 L/min(20USgpm)
Rated pressure	210 bar (3000psi)
Internal leakage (maximum)	less than 5 drops/min @ 85% of nominal setting
Manifold sub-assembly only	4997062-001
Installation kit (includes cap screws, washers and o-rings)	4997242-001

For detailed specifications refer to the RV3A-10 data sheet

## Dimensions

mm (inch)

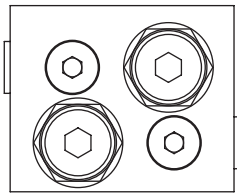

## Port Sizes

"A", "B" – SAE10

"Brake" – SAE4

## Functional Symbol

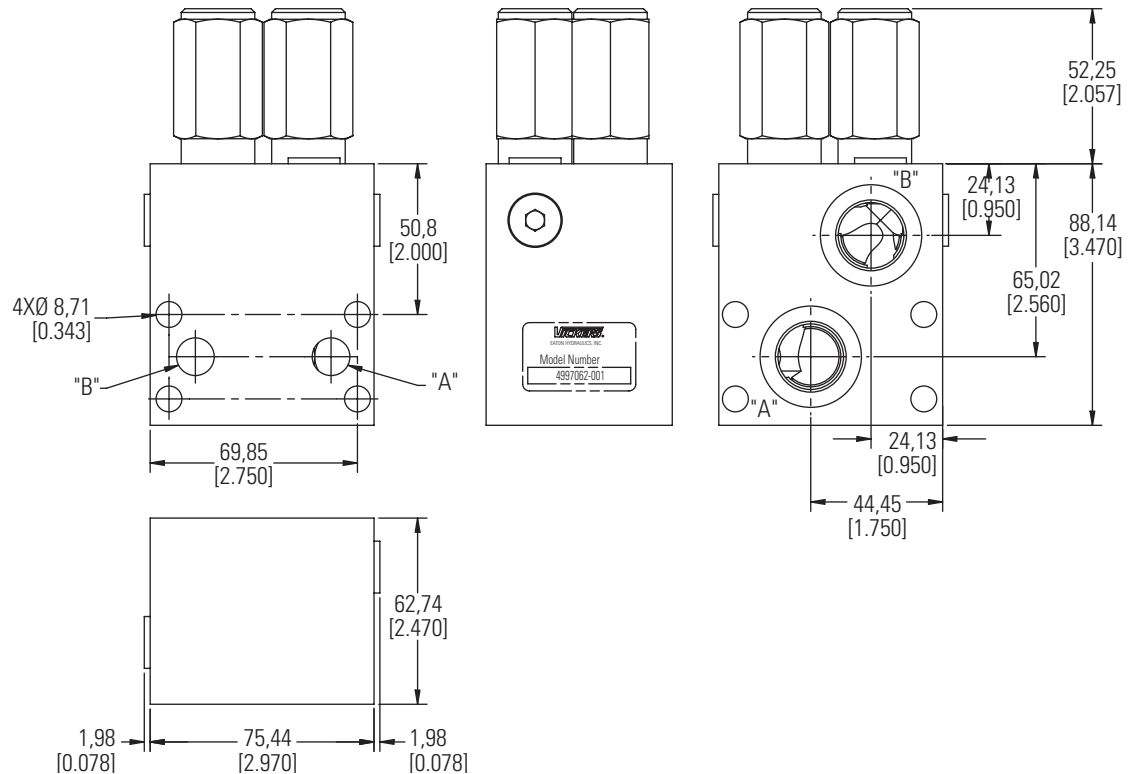
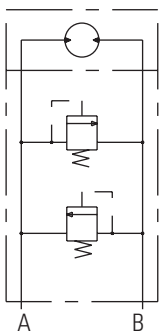

# 1CE2K95/1CEE2K95 - Motor Mounted Valves

## 2K Mounting Pattern Single and Dual Overcenter Valves

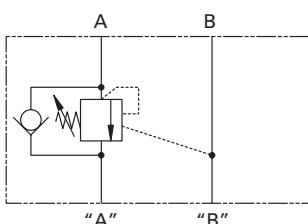

1CE2K95\*A

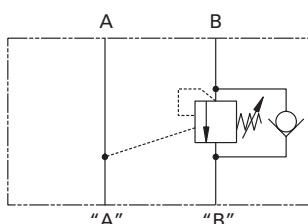

1CE2K95\*B

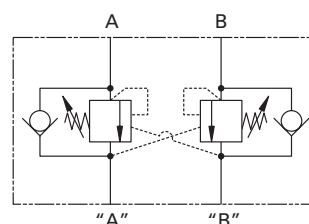

1CEE2K95

### Description

Overcenter valves give static and dynamic control of loads by regulating the flow into and out of hydraulic actuators. When installed close to or within an actuator, the overcenter valve will stop runaway in the event of hose burst and if open center directional control valves are used, will allow thermal expansion relief of the hydraulic fluid.

The overcenter cartridge is ideal for mounting directly into a cavity machined in the body of the cylinder, motor or rotary actuator. The cartridge can also be mounted directly to the ports via a specifically machined body as part of a Hydraulic Integrated Circuit or single unit, or contained within one of our standard line bodies.

Single overcenter valves are normally used when the load is unidirectional, for example an aerial platform or crane and dual overcenter valves are used for controlling loads in both directions for motor applications or for cylinders going over center.

### Operation

The check section allows free flow into the actuator then holds and locks the load against movement. The pilot assisted relief valve section will give controlled movement when pilot pressure is applied. The relief section is normally set to open at a pressure at least 1.3 times the maximum load induced pressure but the pressure required to open the valve and allow movement depends on the pilot ratio of the valve. For optimization of load control and energy usage, a choice of pilot ratios is available.

### Performance Data

#### Ratings and Specifications

Figures based on: Oil Temp = 40°C Viscosity = 32 cSt (150 SUS)

Rated flow	90 L/min (23 USgpm)	
Max setting	Max load induced	
	Pressure:	270 bar (4000 psi)
	Relief setting:	350 bar (5000 psi)
Cartridge material	Working parts hardened & ground steel External surface zinc plated	
Body material	Standard aluminium (up to 210 bar*) Steel (up to 350 bar)	
Mounting position	Unrestricted	
Cavity Number	A12336 (See section M)	
Torque cartridge into cavity	60 Nm (44 lbs ft)	
Weight	1CE2K95	2.16 kg (4.75 lbs)
(inc cartridges)	1CEE2K95	2.26 kg (4.97 lbs)
Seal kit number	1CE2K95	9900830-000 (Buna-N) 9900831-000 (Viton)
	1CEE2K95	9900832-000 (Buna-N) 9900833-000 (Viton)
Recommended filtration level	BS5540/4 Class 18/13 (25 micron nominal)	
Operating Temp	-30°C to +90°C (-22° to 194°F)	
Leakage	0.3 milliL/min nominal (5 dpm)	
Nominal viscosity range	5 to 500 cSt	
Installation Kit (includes cap screws, washers, and o-rings)	9900826-000 (Buna-N) 9900827-000 (Viton)	

The pressure required to open the valve and start actuator movement can be calculated as follows:

$$\text{Pilot Pressure} = \frac{(\text{Relief Setting}) - (\text{Load Pressure})}{\text{Pilot Ratio}}$$

### Pilot Ratios

- 4:1 Best suited for applications where load varies and machine structure can induce instability
- 8:1 Best suited for applications where the load remains relatively constant.

Other ratios available upon request

# 1CE2K95/1CEE2K95 Motor Mounted Valves

2K Mounting Pattern Single and Dual Overcenter Valves

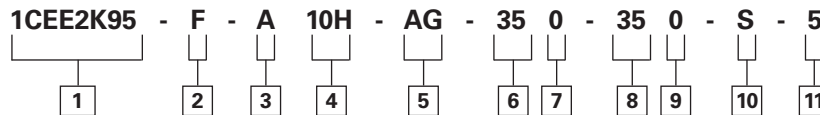
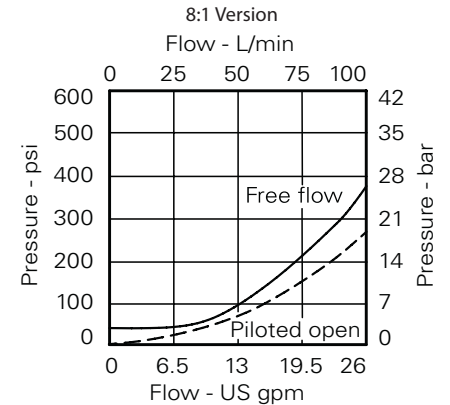
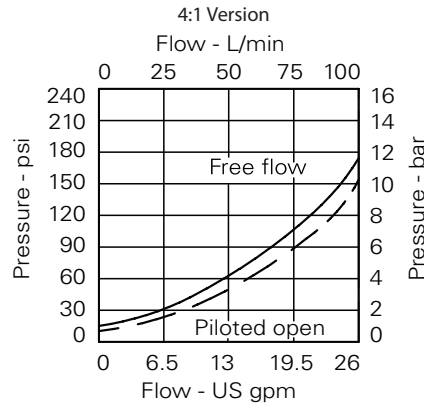

## 1 Basic Code

1CEE2K95 Double Cartridge and Body  
 1CE2K95\*A Single overcenter in line A-"A"  
 1CE2K95\*B Single overcenter in line B-"B"

## 2 Adjustment Means

F - Screw Adjustment

## 3 Housing Material

A - Aluminum  
 S - Steel

## 4

Code	Port Size "A" & "B"	Dual Housing Number	
		Aluminum	Steel
4W	1/2" BSP	6025185-001	6025185-003
10H	SAE 10	6025185-002	
10T	SAE 10		6025185-004

## 5 Port Acted Upon

A - A Port  
 B - B Port  
 AB - A & B Ports (dual)

## 6 Pressure Range (Cart A)

Note: Code Based on pressure in bar.

20 - 70-225 bar. Std setting 100 bar.  
 35 - 200-350 bar. Std setting 210 bar.

## 7 Pressure Setting (Cart A)

0 - Std factory setting  
 1500 - 1500 psi

## 8 Pressure Range (Cart B)

Note: Code Based on pressure in bar.

20 - 70-225 bar. Std setting 100 bar.  
 35 - 200-350 bar. Std setting 210 bar.

## 9 Pressure Setting (Cart B)

0 - Std factory setting  
 1500 - 1500 psi

## 10 Seals

S - Buna-N  
 SV - Viton

## 11 Pilot Ratio

4 - 4:1  
 8 - 8:1

Cavity plug part number

Nitrile - AXP14434-02-N  
 Viton - AXP14434-02-V

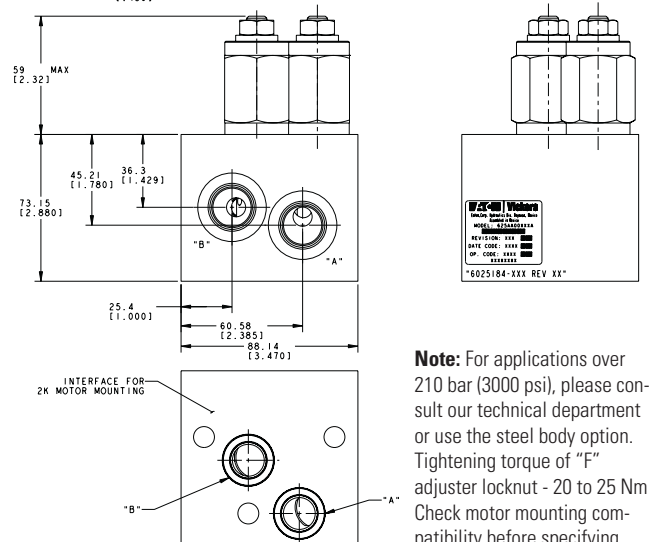
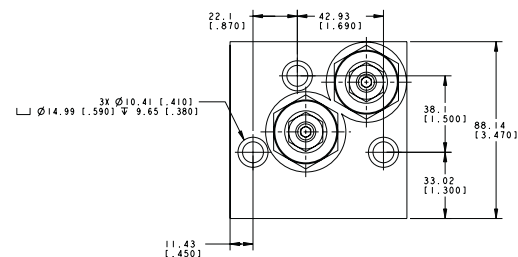

**Note:** For applications over 210 bar (3000 psi), please consult our technical department or use the steel body option. Tightening torque of "F" adjuster locknut - 20 to 25 Nm. Check motor mounting compatibility before specifying.



# ICESH2K95/ICEESH2K95 - Motor

## Mounted Valves

2K Mounting Pattern Single and Dual Overcenter Valves with Brake Release Shuttle

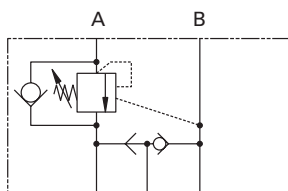

"A" Brake "B"

1CESH2K95\*A

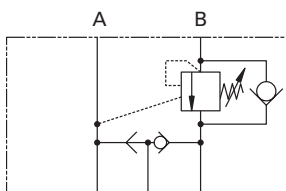

"A" Brake "B"

1CESH2K95\*B

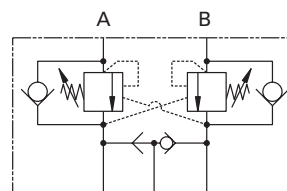

"A" Brake "B"

1CEESH2K95

### Description

Overcenter Valves give static and dynamic control of loads by regulating the flow into and out of hydraulic actuators. When installed close to or within an actuator, the overcenter valve will stop runaway in the event of hose burst and if open center directional control valves are used, will allow thermal expansion relief of the hydraulic fluid.

These dual overcenter valves also contain a brake release shuttle valve which ensures that pressure is applied to a brake release circuit regardless of whether pressure is applied to ports "A" or "B". These multifunction valves are normally used for the static and dynamic control of systems using motors or semi-rotary actuators.

### Operation

The check section allows free flow into the actuator then holds and locks the load against movement. The pilot assisted relief valve section will give controlled movement when pilot pressure is applied. The relief section is normally set to open at a pressure at least 1.3 times the maximum load induced pressure but the pressure required to open the valve and allow movement depends on the pilot ratio of the valve. For optimization of load control and energy usage, a choice of pilot ratios is available.

### Performance Data

#### Ratings and Specifications

Figures based on: Oil Temp = 40°C Viscosity = 32 cSt (150 SUS)

Rated flow	90 L/min (23 USgpm)	
Max setting	Max load induced	
	Pressure:	270 bar (4000 psi)
	Relief setting:	350 bar (5000 psi)
Cartridge material	Working parts hardened & ground steel External surface zinc plated	
Body material	Standard aluminium (up to 210 bar*) Steel (up to 350 bar)	
Mounting position	Unrestricted	
Cavity Number	A12336 (See section M)	
Torque cartridge into cavity	60 Nm (44 lbs ft)	
Weight	1CESH2K95	2.32 kg (5.10 lbs)
(inc cartridges)	1CEESH2K95	2.42 kg (5.32 lbs)
Seal kit number	1CESH2K95 9900834-000 (Buna-N)	9900835-000 (Viton)
	1CEESH2K95 9900836-000 (Buna-N)	9900837-000 (Viton)
Recommended filtration level	BS5540/4 Class 18/13 (25 micron nominal)	
Operating Temp	-30°C to +90°C (-22° to 194°F)	
Leakage	0.3 milliL/min nominal (5 dpm)	
Nominal viscosity range	5 to 500 cSt	
Installation Kit (includes cap screws, washers, and o-rings)	9900828-000 (Buna-N) 9900829-000 (Viton)	

The pressure required to open the valve and start actuator movement can be calculated as follows:

$$\text{Pilot Pressure} = \frac{(\text{Relief Setting}) - (\text{Load Pressure})}{\text{Pilot Ratio}}$$

### Pilot Ratios

- 4:1 Best suited for applications where load varies and machine structure can induce instability
- 8:1 Best suited for applications where the load remains relatively constant.

Other ratios available upon request

# ICESH2K95/ICEESH2K95 - Motor Mounted Valves

2K Mounting Pattern Single and Dual Overcenter Valves with Brake Release Shuttle

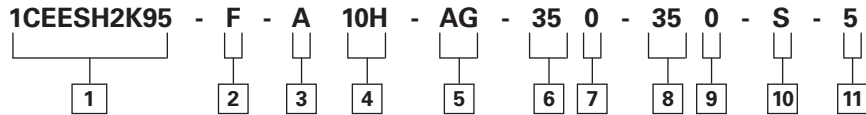
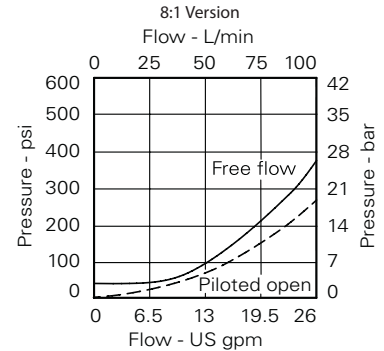
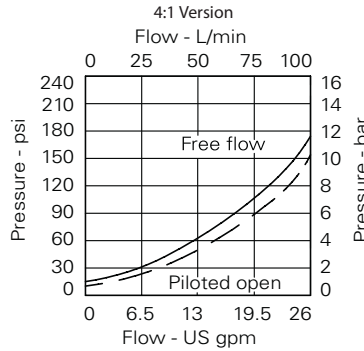

## 1 Basic Code

1CEESH2K95 - Double Cartridge and Body  
 1CESH2K95\*A - Single overcenter in line A-"A"  
 1CESH2K95\*B - Single overcenter in line B-"B"

## 2 Adjustment Means

F - Screw Adjustment

## 3 Housing Material

A - Aluminum  
 S - Steel

## 4

Code	Port Size "A" & "B" Brake		Dual Housing Number	
	"A"	"B"	Aluminum	Steel
4W	1/2" BSP	1/4" BSP	6025134-001	6025134-003
10H	SAE 10	SAE 4	6025134-003	
10T	SAE 10	SAE 4		6025134-004

## 5 Port Acted Upon

A - A Port  
 B - B Port  
 AB - A & B Ports (dual)

## 6 Pressure Range (Cart A)

Note: Code Based on pressure in bar.

20 - 70-225 bar. Std setting 100 bar.  
 35 - 200-350 bar. Std setting 210 bar.

## 7 Pressure Setting (Cart A)

0 - Std factory setting  
 1500 - 1500 psi

## 8 Pressure Range (Cart B)

Note: Code Based on pressure in bar.

20 - 70-225 bar. Std setting 100 bar.  
 35 - 200-350 bar. Std setting 210 bar.

## 9 Pressure Setting (Cart B)

0 - Std factory setting  
 1500 - 1500 psi

## 10 Seals

S - Buna-N  
 SV - VitoN

## 11 Pilot Ratio

4 - 4:1  
 8 - 8:1

Cavity plug part number

Nitrile - AXP13032-01-N  
 Viton - AXP13032-01-V

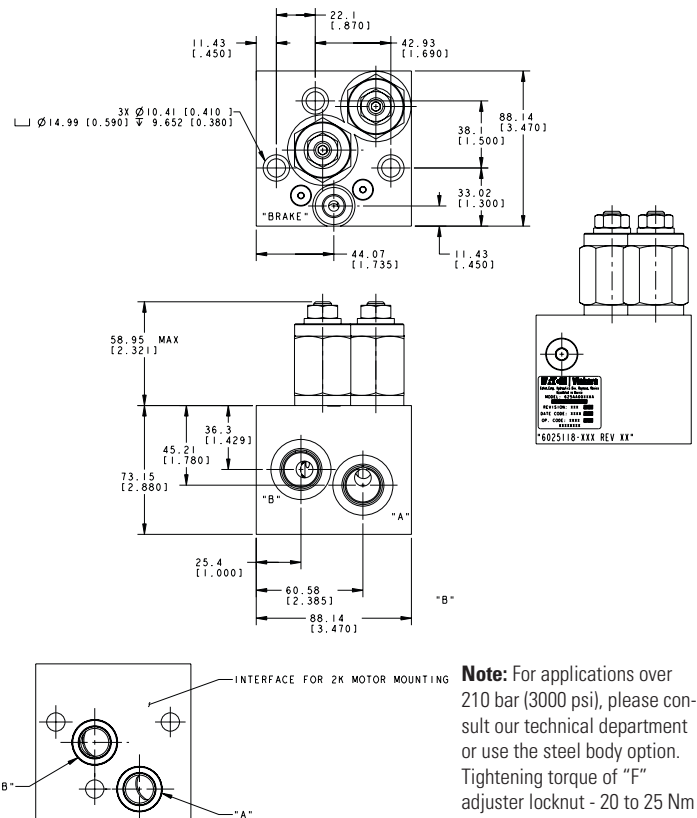

**Note:** For applications over 210 bar (3000 psi), please consult our technical department or use the steel body option. Tightening torque of "F" adjuster locknut - 20 to 25 Nm. Check motor mounting compatibility before specifying.

# Dual Cross-over Relief Package for 2000 Series Disc Valve Motors

Cartridge valves & manifolds for disc valve motors

## Dual Crossover Relief Valve Assembly

This valve assembly provides motor over-pressure protection in both directions of rotation, while supplying the return or lower pressure side of the motor with makeup oil. If closed center valving is used, an additional function is controlled braking.

Typical applications are vehicle propulsion and motor work circuits in which pressure limiting is required.

## How to Order

Complete pre-assembled packages are specified using the RV3A-10 model code. Option "A" must be selected for the cage seals, position 6 of the model code is

"2K". To order the manifold separately, without the two RV3A cartridges, order 4997060-001

## RATINGS AND SPECIFICATIONS

Rated flow	76 L/min(20USgpm)
Rated pressure	210 bar (3000psi)
Internal leakage (maximum)	less than 5 drops/min @ 85% of nominal setting
Manifold sub-assembly only	4997060-001
Installation kit (includes cap screws, washers and o-rings)	02-372492

For detailed specifications refer to the RV3A-10 data sheet.

## Dimensions

mm (inch)

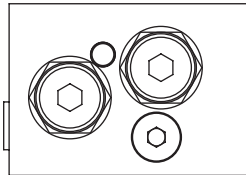

## Port Sizes

"A", "B" – SAE10  
"Brake" – SAE4



## Warning

This manifold package may not be suitable for application with all 2000 series motors - please check installation dimensions carefully.

## Functional Symbol

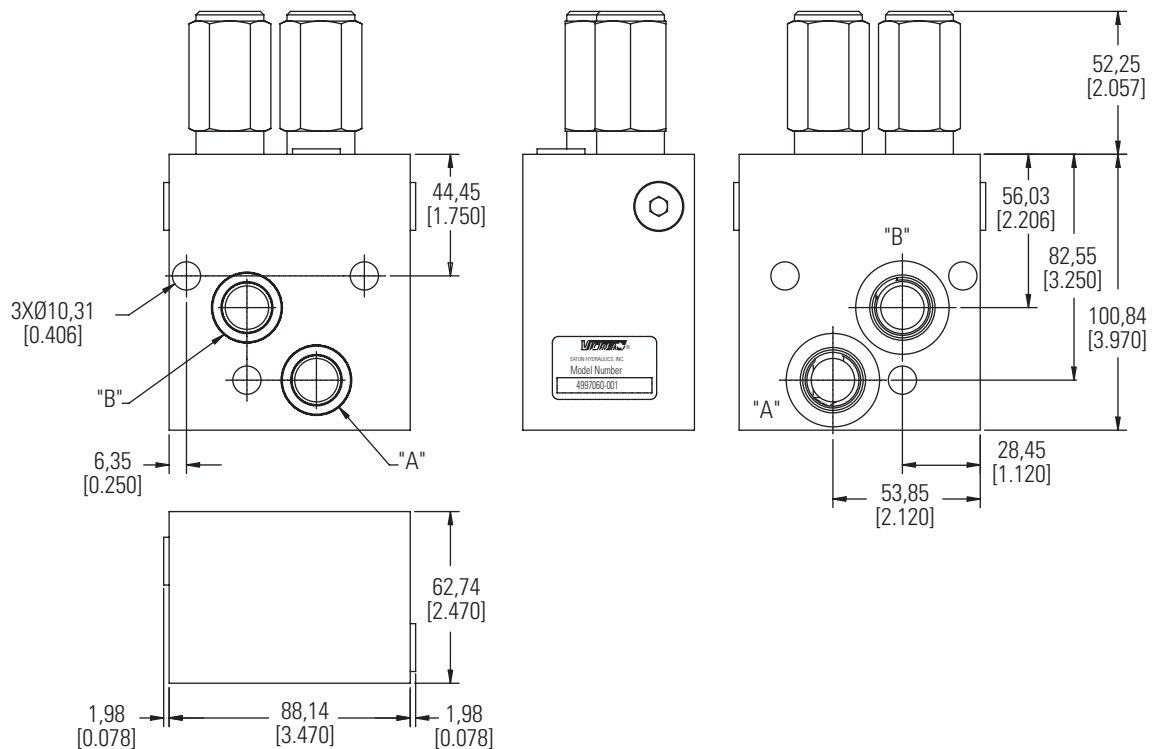
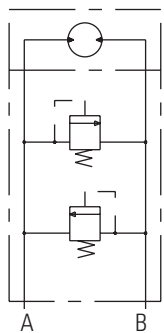

# ATEX Certification

This option is available on H,S,T, 2000 series, 4000 series, 4000 Compact series, 6000 series, 10,000 series, VIS 40, VIS 45 and HP 30 Motors



## What is ATEX Certification?

ATEX certification is a certification that allows our motors to be used in certain types of explosive environments. It derives its name from the French title of the European Union ATEX directive - ATmosphèresEXplosives.

## Benefits

ATEX certification on our motors allows our motors to be used in certain types of explosive environments. When you order an ATEX certified motor, you receive:

- An ATEX certified motor that has the ATEX marking on the label.
- An operating instructions manual
- EC Declaration of Conformity (ATEX Certificate)

## Applications

As mentioned above, it can be any application that operates in explosive environments. Typically, this includes Oil and Gas applications, Mining applications and applications in the rubber industry.

## How to configure an ATEX certified Motor in the model code?

To specify an ATEX certified motor, you will need to select the 'EX' option from the Special features (Hardware) section of the model code for the above motors.

# Fluids Recommendations

Product Line	Viscosity Minimum	Viscosity Best Range	ISO Cleanliness Requirements
J-2, S, W, T Series	70 SUS 13 cst	100-200 SUS 20-43 cst	20/18/13
H Series	100 SUS 20 cst	100-200 SUS 20-43 cst	20/18/13
Disc Values Series	70 SUS 13 cst	100-200 SUS 20-43 cst	20/18/13
VIS Series	70 SUS 13 cst	100-200 SUS 20-43 cst	20/18/13

## Introduction

Hydraulic fluids are one of the vital components of hydraulic system. Proper selection of oil assures satisfactory life and operation of system components. The purpose of this section is to provide readers with the knowledge required to select the appropriate fluids for use in systems that employ Eaton hydraulic components.

### Viscosity and Temperature

Viscosity is the measure of a fluid's resistance to flow. The most important characteristic to consider when choosing a fluid to be used in a hydraulic system is viscosity. The fluid must be thin enough to flow easily but thick enough to maintain adequate lubricating film between component and to maintain proper sealing at the operating temperatures of the hydraulic system. For viscosity requirements see table. Viscosity of any fluid is relative to temperature, as the fluid warms the viscosity decreases and vice versa. When choosing a fluid,, it is important to consider the start-up and operating temperatures of the hydraulic system. A high VI fluid shows relatively small change of viscosity with temperature. Lubricants used for hydraulic applications may contain viscosity index improvers (VII). They refer to these fluids as viscosity index improved, or multi-viscosity fluids. The viscosity of these fluids may drop down in use due to the shearing of VI improvers used in the

formulations. Anti-wear hydraulic oils containing polymeric thickeners (Viscosity Index Improvers [VII]) are generally used for wide band operating temperature applications. These fluids experience temporary and permanent viscosity loss during use in hydraulic system. Check the extent of viscosity loss (shear stability) to avoid hydraulic service below the recommended minimum viscosity. Oil with good shear stability is recommended for wide band temperature applications. Multi-grade engine oils, ATFs, UTTOs, etc., also contain VIIs, and viscosity loss will be encountered during use.

## Cleanliness

Cleanliness of the fluid in a hydraulic system is extremely important. More than 70% of all failures are caused by contamination. Eaton recommends that the fluids used in its hydraulic components be maintained per ISO 4406. Cleanliness level requirements varies with the hydraulic components. The cleanliness of a hydraulic system is dictated by the cleanliness requirement of the most stringent component in the system. Cleanliness requirements for specific products are given in the table. OEMs and distributors who use Eaton hydraulic components in their products should provide for these requirements in their design. A reputable filter supplier can supply filter information.

## Fluid Maintenance

The condition of a fluid has a direct effect on the performance and reliability of the system. Maintaining proper fluid viscosity, cleanliness level, water content, and additive level is essential for excellent hydraulic system performance. Routine fluid condition monitoring is recommended.

## Fluid Selection

Premium grade anti-wear (AW) petroleum based hydraulic fluids will provide the best performance in Eaton hydraulic components. Lubricants that pass Eaton Vickers® 35VQ25A high-pressure vane pump test (Eaton ATS-373 test procedure, ASTM Specification D-6973) are considered good quality, anti-wear hydraulic fluids. Automotive crankcase oils with American Petroleum Institute (API) letter designation SE, SF, SG, SH, or higher per SAE J183 classes of oils are recommended for applications using Eaton GG motors. Automotive crankcase oils generally exhibit less shear stability compared to industrial anti-wear hydraulic fluids, which can result in higher loss of viscosity during service life. Other mineral oil-based lubricants commonly used in hydraulic systems are automatic transmission fluids (ATFs) and universal tractor transmission oils (UTTOs). Synthetic hydrocarbon base stocks, such as polyalphaolefins (PAOs), are also

used to formulate hydraulic fluids, engine oils, ATFs and UTTOs. Alternative fluids are recommended when specific properties, such as fire resistance, biodegradability, etc., are necessary for the application. Keep in mind that alternative fluids may differ from AW petroleum fluids in properties such as pressure viscosity coefficient, specific gravity, lubricity, etc. Hence, GG motors may need to be derated, some can be operated under full ratings, and other are not rated.

## Additional Notes:

When choosing a hydraulic fluid, all the components in the system must be considered. Viscosity limitations has to meet the most stringent components requirements. For any system where the fluid is non petroleum oil, set the target one ISO range code cleaner for each particle size, than that of petroleum fluids. Keep adequate fluid level in the reservoir. Take fluid level reading when the system is cold. For more details, refer to Eaton Fluid Recommendation Document # 03-401-2010

Contact your Eaton representative if you have specific questions about the fluid requirements of Eaton hydraulic components.



B-1

B-2

B-3

B-4

B-5



Spool Valve motors incorporate the proven orbit motor principle to provide high torque at low speeds.

# Spool Valve Motors

## Highlights

### Product Description

Char-Lynn spool valve motors distribute pressurized fluid into and out of the Orbit gear set (Gerotor or Geroler) via valve slots integrated into the output shaft. The spool valve motors incorporate both valving and hydrodynamic journal bearings into a common shaft design. The valve section (spool valve) can be optimized for low flow, low speed needs using a low speed spool option to enhance smooth running performance.

These motors incorporate the proven orbit motor principle to provide high torque at low speeds.

Motor shaft rotation can be instantly reversed by changing direction of input/output flow while generating equal torque in either direction. The displacements available provide a wide variety of speeds and torques from any spool valve motor series.

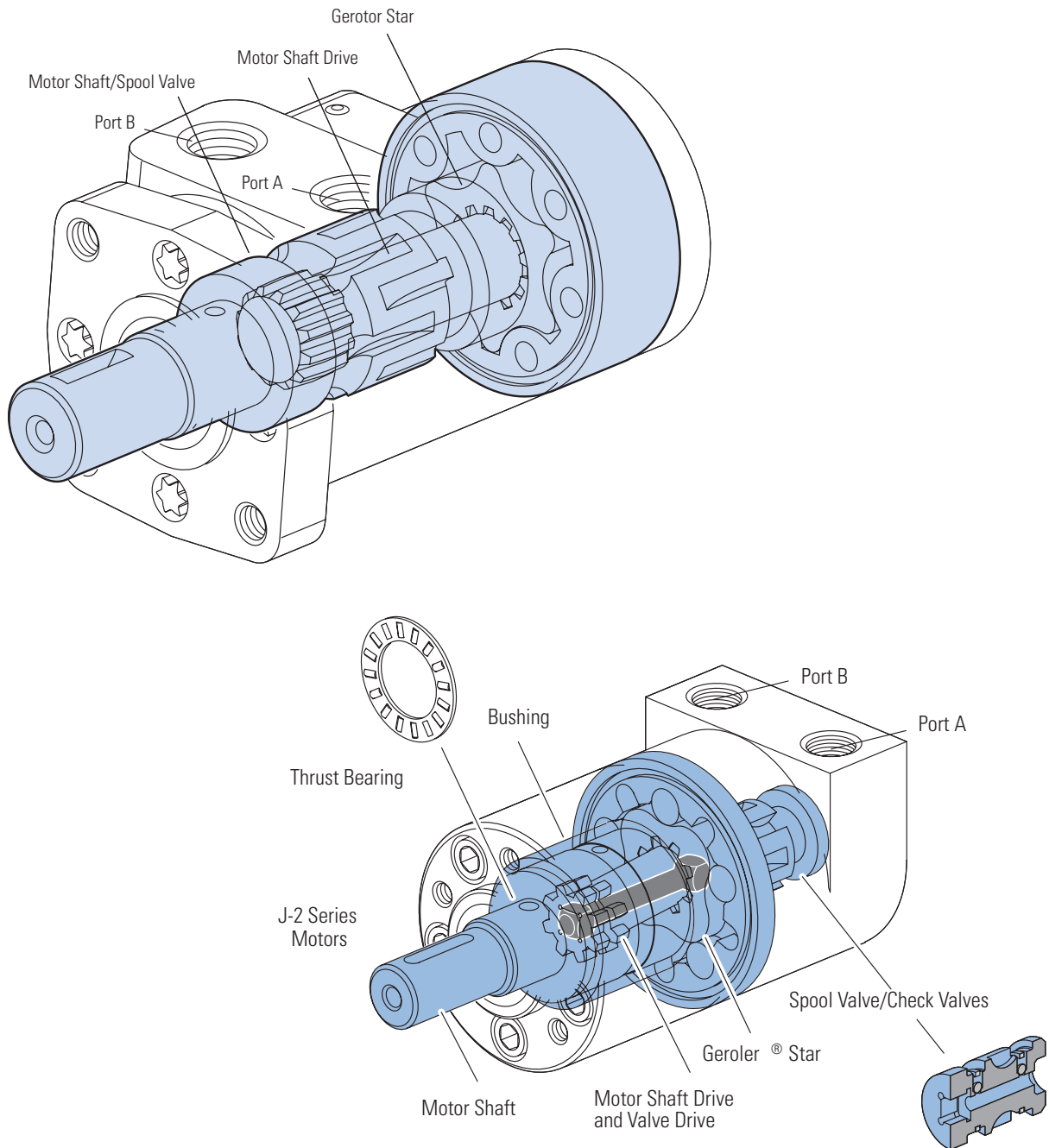



# Features, Benefits, and Applications

B-1

B-2

B-3

B-4

B-5

## Features

- Proven Orbit Motor Principle
- Hydrodynamic Journal Bearings
- Constant Clearance Geroler
- Three-Zone Pressure Design
- Reduced drive running-angle
- High-pressure seals
- Modular design

## Benefits

- Compact, powerful package
- Infinite bearing life (at rated loads)
- High efficiency
- Increases shaft seal & bearing life
- Smooth operation, increases drive life
- Reduces leakage
- Design flexibility
- Economically tailored solutions

## Applications

- Harvesters
- Augers
- Spreaders
- Machine tools
- Conveyors
- Winches
- Turf care equipment
- Food processing
- Aerial Work Platforms
- Anywhere a compact drive with high output torque is needed

## Design Features

Spool valve technology is typically used where compact, economical solutions are most needed. Spool valve motors use a spool valve to precisely time and control flow through the orbit gear set (Gerotor or Geroler). Inlet flow is directed into and out of the orbit set via slots in the spool and passages through the motor housing. The result is a very cost-effective compact package suited to many application requirements. The three

primary components in the motor are the orbit star, drive and output shaft. H, S and T Series incorporate the spool valve and hydrodynamic bearings in the motor shaft. The W series is similar except a ball bearing is used for the front bearing for increased side-load capacity. Due to its compact size and high speed capability, the J Series is unique and utilizes a separate dedicated spool and spool valve drive. All motors utilize Eaton's

constant-clearance Geroler technology except the H Series, which continues to use the time-proven H motor gerotor set. These motors all use a three-zone pressure design consisting of three unique pressure areas: 1) inlet, 2) return, 3) case. This provides the capability to limit motor case pressure and allows the use of several case pressure options for extended shaft seal and thrust bearing life.

Below is a quick-guide to help select the proper motor for your application:

### MOTOR QUICK-GUIDE (BASED ON MAXIMUM CONTINUOUS RATINGS)

Series	Output Torque Nm [lb-in]	Pressure bar [psi]	Flow lpm [gpm]	Side Load kg [lbs]
J Series	62 [550]	140 [2030]	21 [5.5]	196 [430]
H Series	407 [3607]	124 [1800]	57 [15]	635 [1400]
S Series	430 [3800]	135 [2000]	55 [15]	635 [1400]
T Series	450 [4000]	155 [2250]	55 [15]	635 [1400]
W Series	410 [3625]	165 [2400]	68 [18]	845 [1900]

\* The above are provided as guidelines only. Actual ratings vary depending on final motor configuration

# Table of Contents

Highlights	B-ii
Features, Benefits, and Applications	B-iii

## **J Series (129-)**

Highlights	B-1-1
Specifications	B-1-2
Performance Data	B-1-3
Dimensions	B-1-5
Product Numbers	B-1-9
Shaft Side Load Capacity	B-1-10
Case Pressure and Case Drain	B-1-11
Model Code	B-1-12

## **H Series (101-)**

Highlights	B-2-1
Specifications	B-2-2
Performance Data	B-2-3
Dimensions	B-2-9
Product Numbers	B-2-10
Model Code	B-2-11

## **S Series (103-)**

Highlights	B-3-1
Specifications	B-3-2
Performance Data	B-3-3
Dimensions	B-3-8
Product Numbers	B-3-9
S Series with Low Speed Valving	B-3-10
Model Code	B-3-11

## **T Series (158-)**

Highlights	B-4-1
Specifications	B-4-2
Performance Data	B-4-3
Dimensions	B-4-8
Product Numbers	B-4-9
Model Code	B-4-10

## **T Series with Parking Brake (185-)**

Highlights	B-4-11
Application Information	B-4-12
Specifications	B-4-13
Dimensions	B-4-14
Brake Release and Motor Case Pressure	B-4-15
Product Numbers	B-4-16
Model Code	B-4-17

## **H, S and T Series (101-, 103-, 158-, 185-)**

Side Load Capacity	B-4-18
Dimensions	B-4-19
Mounting Options	B-4-21

## **W Series (162-)**

Highlights	B-5-1
Specifications	B-5-2
Performance Data	B-5-3
Dimensions	B-5-5
Dimensions Shafts	B-5-6
Shaft Side Load Capacity	B-5-7
Model Code	B-5-8

## **W Series with Parking Brake (162-)**

Dimensions	B-5-9
Product Numbers	B-5-10
Model Code	B-5-11

# J Series (129-)

## Highlights

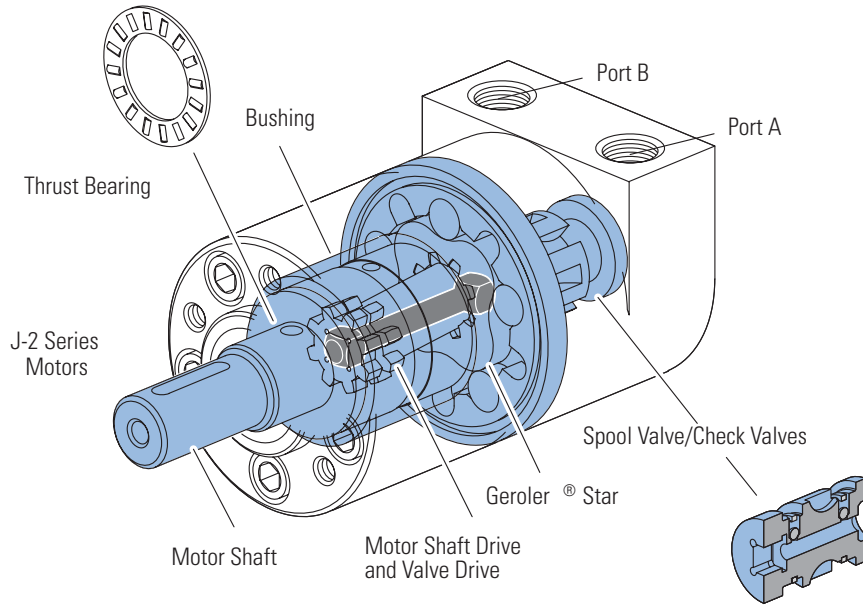

### Description

Char-Lynn J Series motors provide a lot of power from a very small package. Up to 5 kW [6 1/2 HP] of power. These motors are 61 mm [2.4 in] in diameter and 104 to 130 mm [4.1 to 5.1 in] in length.

The J Series motor shaft and seal allows high case pressure up to 76 bar [1100 PSI] return line pressure without case drain line. When a case drain line is used a 220 bar [3190 PSI] peak pressure is allowed in the return line.

### Specifications

Geroler Element	5 Displacements
Flow l/min [GPM]	21 [5.5] Continuous*** 25 [6.5] Intermittent**
Speed	Up to 1992 RPM Cont. Up to 2458 RPM Inter.
Pressure bar [PSI]	140 [2030] Cont.*** 165 [2400] Inter.**
Torque Nm [lb-in]	62 [549] Cont.*** 84 [743] Inter.**

\*\*\* Continuous—(Cont.) Continuous rating, motor may be run continuously at these ratings.

\*\* Intermittent—(Inter.) Intermittent operation, 10% of every minute.

### Features:

- Constant clearance Geroler set
- Integrated check valves
- Self-lubricating shaft bushing
- High-strength rigid components
- Increased valve seal lands
- High pressure seals
- Variety of displacements, shafts, mounts and special options

### Benefits:

- High efficiency
- Extended leak-free performance
- Powerful compact package
- Design flexibility

### Applications:

- Agricultural augers, harvesters, seeders
- Car wash tire spray wands and brushes
- Marine bow thrusters
- Food processing
- Railroad maintenance equipment
- Machine tools
- Conveyors
- Snow blower chute rotor
- Industrial sweepers and floor polishers
- Saw mill works
- Turf equipment reel drives
- Paint stripper
- Many more

B-1



Plastic Injection



Metal Forming



Food Processing



Ship-Boat Building

# J Series (129-)

## Specifications

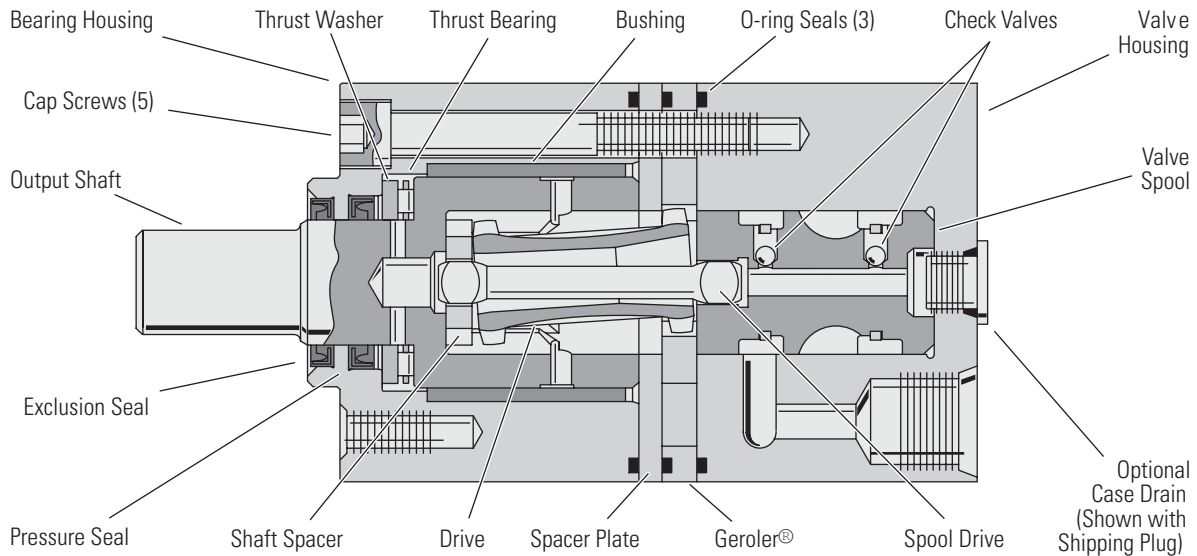

### SPECIFICATION DATA – J MOTORS

Displ. cm <sup>3</sup> /r [in <sup>3</sup> /r]		8,2 [.50]	12,9 [.79]	19,8 [1.21]	31,6 [1.93]	50,0 [3.00]
Max. Speed (RPM) @ Continuous Flow		1992	1575	1043	650	393
Flow l/min [GPM]	Continuous	17 [4.5]	21 [5.5]	21 [5.5]	21 [5.5]	21 [5.5]
	Intermittent	21 [5.5]	25 [6.5]	25 [6.5]	25 [6.5]	25 [6.5]
Torque Nm [lb-in]	Continuous	16 [141]	25 [225]	38 [333]	50 [446]	62 [549]
	Intermittent	19 [164]	30 [263]	46 [405]	62 [546]	84 [743]
	Peak	22 [193]	36 [321]	48 [425]	83 [733]	86 [765]
Pressure Δ bar [Δ PSI]	Continuous	140 [2030]	140 [2030]	140 [2030]	121 [1750]	97 [1400]
	Intermittent	165 [2400]	165 [2400]	165 [2400]	150 [2175]	140 [2030]
	Peak	220 [3190]	220 [3190]	220 [3190]	190 [2756]	150 [2175]
Weight kg [lbs]		2 [4.4]	2,1 [4.6]	2,2 [4.8]	2,3 [5.0]	2,4 [5.4]

\* Maximum pressure at motor inlet port is 220 Bar [3190 PSI] without regard to Δ bar [Δ PSI] and/or back pressure ratings or combination thereof.

#### Note:

To assure best motor life, run motor for approximately one hour at 30% of rated pressure before application to full load. Be sure motor is filled with fluid prior to any load applications.

#### Δ Pressure:

The true Δ bar [Δ PSI] difference between inlet port and outlet port.

See individual shafts for maximum torque recommendation. Splined shafts are recommended for those applications subject to frequent reversals.

#### Continuous Rating:

Motor may be run continuously at these ratings

#### Intermittent Operation:

10% of every minute

#### Peak Operation:

1% of every minute

#### Recommended Fluids:

Premium quality, anti-wear type hydraulic oil with a viscosity of not less than 70 SUS at operating temperature.

#### Recommended System Operating Temp.:

-34°C to 82°C  
[-30°F to 180°F]

#### Recommended Filtration:

per ISO Cleanliness Code 4406, level 20/18/13

# J Series (129-)

## Performance Data

Motors run with high efficiency in all areas designated with a number for torque and speed. For best motor life select a motor to run with a torque and speed range shown in the light shaded area.

Performance data is typical at 120 SUS. Actual data may vary slightly from motor to motor in production.

8,2 cm<sup>3</sup>/r [.50 in<sup>3</sup>/r]

D Pressure Bar [PSI]

Continuous

Max. Continuous

Max. Intermittent

		[200] 14	[400] 28	[500] 34	[600] 41	[700] 48	[800] 55	[1000] 69	[1400] 97	[1500] 103	[2000] 138	[2030] 140	[2400] 165
Flow LPM [GPM]	[1] 3,8	[11] 1 456	[25] 3 444	[33] 4 437	[40] 5 429	[47] 5 422	[55] 6 412	[69] 8 394	[96] 11 347	[102] 12 332	[130] 15 250	[132] 15 239	[146] 16 170
	[2] 7,6	[9] 1 897	[24] 3 886	[31] 4 877	[38] 4 867	[46] 5 860	[53] 6 847	[68] 8 823	[97] 11 768	[105] 12 749	[139] 16 657	[141] 16 647	[163] 18 557
	[3] 11,4	[6] 1 1349	[20] 2 1331	[28] 3 1318	[35] 4 1309	[44] 5 1296	[51] 6 1285	[65] 7 1261	[94] 11 1198	[102] 12 1176	[137] 15 1070	[139] 16 1060	[164] 19 959
	[4.25] 16,0		[16] 2 1902	[23] 3 1885	[30] 3 1873	[36] 4 1858	[44] 5 1846	[60] 7 1817	[90] 11 1750	[97] 12 1721	[133] 15 1599	[135] 15 1585	[160] 18 1475
Max. Continuous	[4.5] 17,0		[16] 2 1992	[23] 3 1979	[29] 3 1964	[36] 4 1947	[43] 5 1929	[59] 7 1900	[89] 10 1833	[96] 11 1808	[131] 15 1684	[134] 15 1673	[160] 18 1553
	Max. Intermittent 20,8		[12] 1 2458	[18] 2 2437	[26] 3 2420	[33] 4 2405	[40] 5 2387	[54] 6 2353	[83] 9 2272	[92] 10 2255	[124] 14 2134	[129] 15 2115	[154] 17 1994

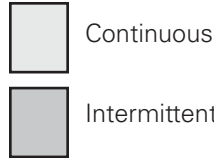

12,9 cm<sup>3</sup>/r [0.79 in<sup>3</sup>/r]

D Pressure Bar [PSI]

Continuous

Max. Continuous

Max. Intermittent

		[200] 14	[400] 28	[500] 34	[600] 41	[700] 48	[800] 55	[1000] 69	[1400] 97	[1450] 100	[1500] 103	[2000] 138	2030 140	[2400] 165
Flow LPM [GPM]	[1] 3,8	[19] 2 290	[43] 5 285	[54] 6 281	[65] 7 277	[76] 9 273	[88] 10 268	[109] 12 260	[154] 17 237	[159] 18 234	[164] 19 230	[214] 24 194	[217] 25 189	[250] 28 151
	[2] 7,6	[16] 2 573	[39] 4 566	[51] 6 561	[63] 7 555	[74] 8 549	[86] 10 544	[109] 12 534	[155] 18 501	[160] 19 496	[165] 20 490	[221] 25 442	[225] 25 437	[263] 30 396
	[3] 11,4	[11] 1 859	[35] 4 849	[47] 5 843	[58] 7 838	[70] 8 832	[82] 9 825	[105] 12 810	[152] 17 777	[157] 18 771	[163] 19 763	[219] 25 708	[223] 25 701	[263] 30 652
	[4] 15,1	[6] 1 1153	[30] 3 1140	[41] 5 1135	[53] 6 1129	[64] 7 1124	[76] 9 1117	[99] 11 1101	[146] 16 1060	[152] 17 1051	[157] 18 1044	[214] 24 982	[217] 25 975	[260] 29 924
Max. Continuous	[5.5] 20,8		[19] 2 1575	[30] 3 1566	[42] 5 1556	[54] 6 1547	[65] 7 1539	[89] 10 1521	[136] 15 1473	[142] 16 1466	[148] 17 1457	[205] 23 1396	[209] 24 1387	[251] 28 1330
	Max. Intermittent 24,6		[11] 1 1859	[23] 3 1851	[35] 4 1842	[46] 5 1831	[56] 6 1820	[81] 9 1804	[130] 15 1755	[135] 15 1743	[140] 16 1734	[198] 22 1670	[202] 23 1663	[243] 27 1599

[42]  
5 } Torque [lb-in]  
Nm  
1556 } Speed RPM

# J Series (129-)

## Performance Data

Motors run with high efficiency in all areas designated with a number for torque and speed. For best motor life select a motor to run with a torque and speed range shown in the light shaded area.

Performance data is typical at 120 SUS. Actual data may vary slightly from motor to motor in production.

### 19.8 cm<sup>3</sup>/r [1.21 in<sup>3</sup>/r] D Pressure Bar [PSI] Continuous

		[200] 14	[400] 28	[500] 34	[600] 41	[700] 48	[800] 55	[1000] 69	[1400] 97	[1450] 100	[1500] 103	[2000] 138	[2030] 140	[2400] 165
Flow LPM [GPM]	[1] 3,8	[32] 4 189	[67] 8 187	[85] 10 186	[102] 12 185	[119] 13 183	[136] 15 182	[170] 19 179	[236] 27 172	[244] 28 170	[253] 29 169	[321] 36 141	[325] 37 138	[374] 42 114
	[2] 7,6	[30] 3 379	[65] 7 375	[83] 9 373	[101] 11 370	[119] 13 368	[136] 15 366	[172] 19 361	[223] 25 351	[248] 28 349	[257] 29 347	[328] 37 312	[333] 38 309	[388] 44 285
	[3] 11,4	[21] 2 569	[57] 6 565	[75] 8 563	[93] 11 560	[111] 13 558	[128] 14 556	[163] 18 551	[231] 26 529	[240] 27 526	[248] 28 523	[325] 37 487	[330] 37 484	[405] 46 459
	[4] 15,1	[12] 1 761	[47] 5 758	[65] 7 754	[83] 9 751	[101] 11 749	[119] 13 746	[154] 17 741	[221] 25 717	[230] 26 711	[239] 27 707	[316] 36 660	[320] 36 656	[382] 43 628
Max. Continuous	[5.5] 20,8	[31] 4 1043	[49] 6 1040	[67] 8 1035	[84] 9 1033	[101] 11 1028	[137] 15 1021	[202] 23 997	[211] 24 993	[218] 25 990	[295] 33 938	[299] 34 934	[365] 41 899	
Max. Intermittent	[6.5] 24,6	[21] 2 1226	[38] 4 1222	[56] 6 1219	[74] 8 1215	[91] 10 1211	[126] 14 1204	[189] 21 1179	[196] 22 1174	[206] 23 1169	[278] 31 1121	[283] 32 1117	[347] 39 1079	

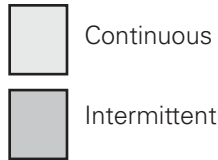

### 31.6 cm<sup>3</sup>/r [1.93 in<sup>3</sup>/r] D Pressure Bar [PSI] Continuous

		[200] 14	[400] 28	[500] 34	[600] 41	[700] 48	[800] 55	[1000] 69	[1400] 97	[1450] 100	[1500] 103	[1750] 121	[2175] 150
Flow LPM [GPM]	[1] 3,8	[51] 6 118	[106] 12 116	[133] 15 115	[160] 18 113	[187] 21 112	[213] 24 111	[265] 30 107	[362] 41 91	[372] 42 85	[383] 43 81	[439] 50 70	
	[2] 7,6	[46] 5 236	[103] 12 234	[132] 15 232	[159] 18 230	[187] 21 228	[214] 24 225	[269] 30 221	[362] 41 187	[374] 42 179	[387] 44 175	[446] 50 165	[546] 62 145
	[3] 11,4	[36] 4 355	[94] 11 352	[122] 14 349	[149] 17 347	[177] 20 345	[205] 23 342	[259] 29 336	[351] 40 296	[364] 41 292	[377] 43 287	[440] 50 273	[542] 61 245
	[4] 15,1	[24] 3 474	[79] 9 472	[107] 12 469	[135] 15 466	[162] 18 462	[190] 21 460	[246] 28 452	[337] 38 404	[349] 39 397	[362] 41 393	[425] 48 373	[528] 60 346
Max. Continuous	[5.5] 20,8	[55] 6 650	[83] 9 647	[111] 13 645	[139] 16 640	[167] 19 636	[221] 25 629	[307] 35 584	[320] 36 580	[334] 38 575	[400] 45 550	[505] 57 513	
Max. Intermittent	[6.5] 24,6	[35] 4 767	[64] 7 764	[93] 11 760	[121] 14 755	[150] 17 751	[204] 23 742	[279] 32 712	[294] 33 707	[308] 35 701	[378] 43 675	[485] 55 637	

### 50.0 cm<sup>3</sup>/r [3.00 in<sup>3</sup>/r] D Pressure Bar [PSI] Continuous

		[200] 14	[400] 28	[500] 34	[600] 41	[700] 48	[800] 55	[1000] 69	[1100] 76	[1200] 83	[1300] 90	[1400] 97	[2030] 140
Flow LPM [GPM]	[1] 3,8	[82] 9 75	[167] 19 72	[211] 24 72									
	[2] 7,6	[70] 8 149	[156] 18 147	[201] 23 145	[243] 28 144	[286] 32 143	[327] 37 142						
	[3] 11,4	[53] 6 221	[140] 16 220	[184] 21 218	[227] 26 217	[271] 31 215	[311] 35 213	[396] 45 209	[441] 50 205	[484] 55 201	[521] 59 200	[549] 62 191	
	[4] 15,1	[30] 3 296	[120] 14 292	[162] 18 289	[204] 23 286	[250] 28 284	[292] 33 282	[374] 42 273	[419] 47 270	[460] 52 265	[501] 57 263	[541] 61 259	[743] 84 213
Max. Continuous	[5.5] 20,8	[81] 9 393	[127] 14 392	[170] 19 389	[214] 24 387	[254] 29 383	[339] 38 377	[379] 43 372	[422] 48 369	[463] 52 364	[506] 57 358	[702] 79 302	
Max. Intermittent	[6.5] 24,6	[47] 5 465	[90] 10 462	[133] 15 460	[176] 20 458	[219] 25 455	[307] 35 448	[345] 39 445	[385] 43 440	[429] 48 435	[467] 53 430	[685] 77 364	

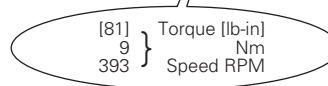

# J Series (129-)

## Dimensions

### Standard Rotation Viewed from Shaft End

Port A Pressurized — CW

Port B Pressurized — CCW

### 9/16 Inch End Port

9/16 -18 UNF - 2B O-Ring Ports, M14 x 1,5  
 - 6H O-Ring Ports — Metric Motor or  
 G 1/4 (BSP) Ports (2 Ports each)

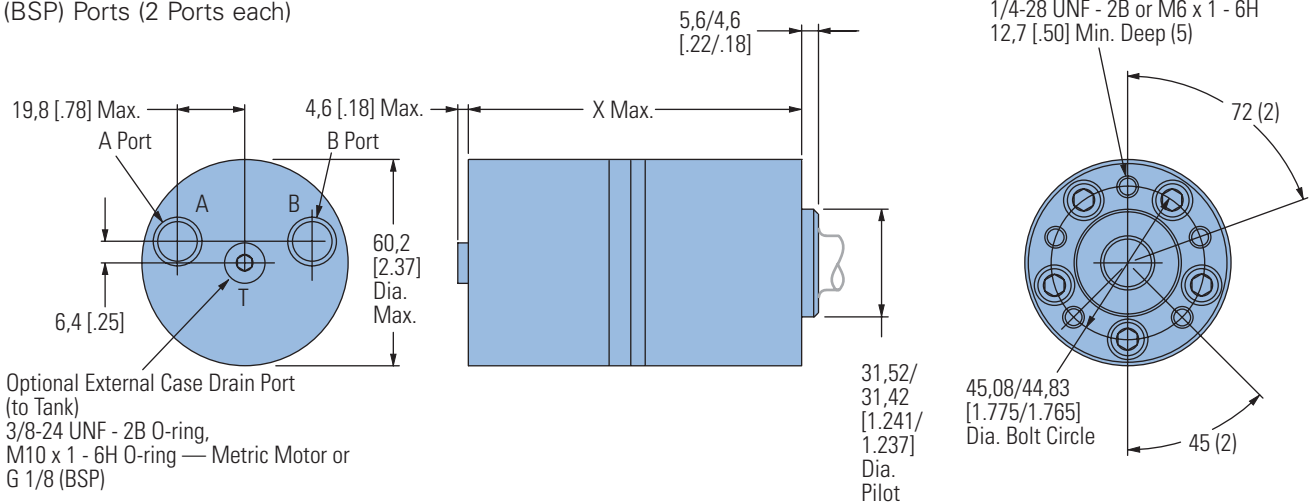

Optional External Case Drain Port  
 (to Tank)  
 3/8-24 UNF - 2B O-ring,  
 M10 x 1 - 6H O-ring — Metric Motor or  
 G 1/8 (BSP)

#### END PORT DIMENSIONS

Displacement cm <sup>3</sup> /r [in <sup>3</sup> /r]	X mm [inch]
8,2 [ .50]	103,9 [4.09]
12,9 [ .79]	106,9 [4.21]
19,8 [1.21]	112,5 [4.38]
31,6 [1.93]	118,9 [4.68]
50,0 [3.00]	130,3 [5.13]

### 3/8 Inch End Port

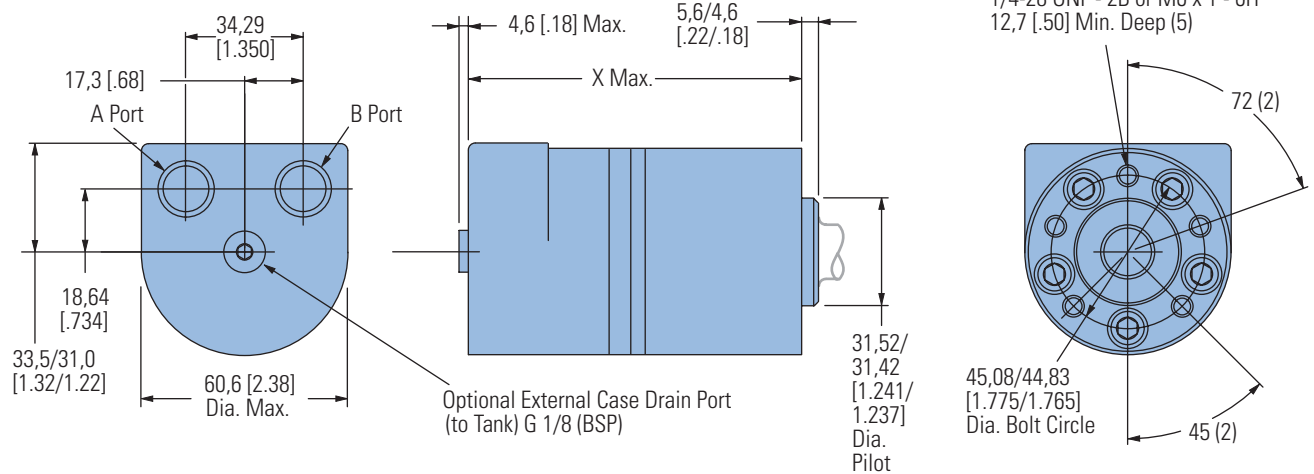

Optional External Case Drain Port  
 (to Tank) G 1/8 (BSP)

#### END PORT DIMENSIONS

Displacement cm <sup>3</sup> /r [in <sup>3</sup> /r]	X mm [inch]
8,2 [ .50]	103,9 [4.09]
12,9 [ .79]	106,9 [4.21]
19,8 [1.21]	112,5 [4.38]
31,6 [1.93]	118,9 [4.68]
50,0 [3.00]	130,0 [5.12]
160,5 [6.32]	132,3 [5.21]

# J Series (129-)

## Dimensions

### Ports

9/16 -18 UNF - 2B O-Ring Ports,  
 M14 x 1,5 -6H O-Ring Ports — Metric Motor,  
 G 3/8 or G 1/4 (BSP) Ports (2)

### Standard Rotation Viewed from Shaft End

Port A Pressurized — CW  
 Port B Pressurized — CCW

## Side Port

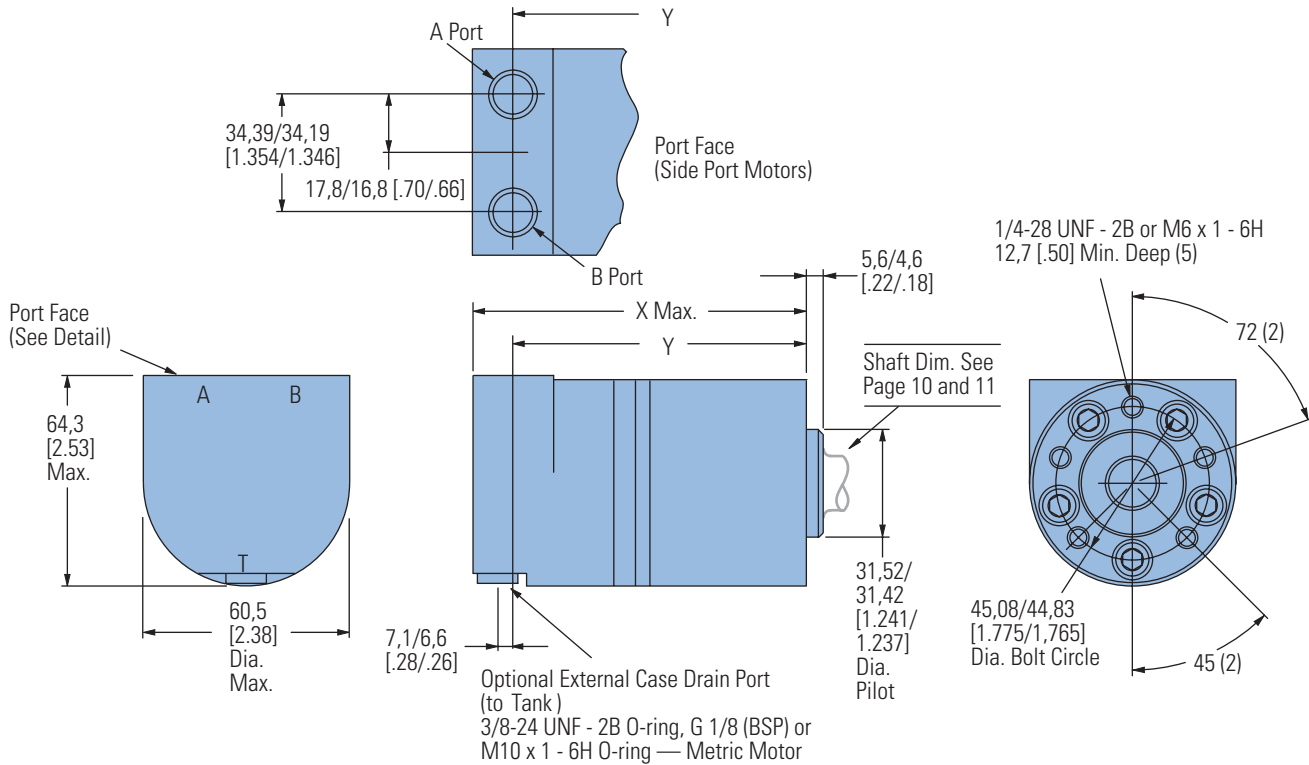

### SIDE PORT MOTORS

Displacement $\text{cm}^3/\text{r}$ [ $\text{in}^3/\text{r}$ ]	X mm [inch]	Y mm [inch]
8,2 [.50]	103,9 [4.09]	89,4/ 87,4 [3.52/3.44]
12,9 [.79]	106,9 [4.21]	92,5/ 90,4 [3.64/3.56]
19,8 [1.21]	112,5 [4.38]	96,8/ 94,7 [3.81/3.73]
31,6 [1.93]	118,9 [4.68]	104,4/102,4 [4.11/4.03]
50,0 [3.00]	130,0 [5.12]	115,7/113,9 [4.56/4.48]



# J Series (129-)

## Dimensions

### Shafts

### 5/8 Inch Straight Keyed

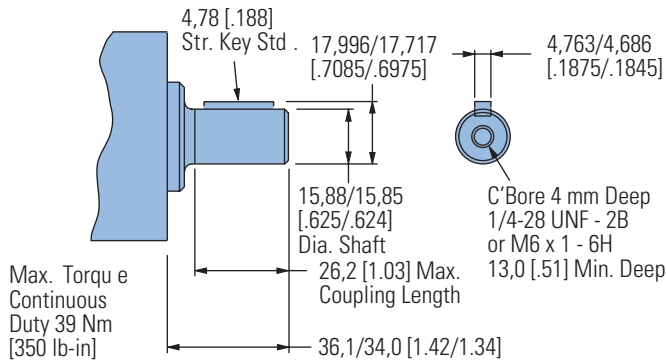

### 11/16 Inch Straight Keyed

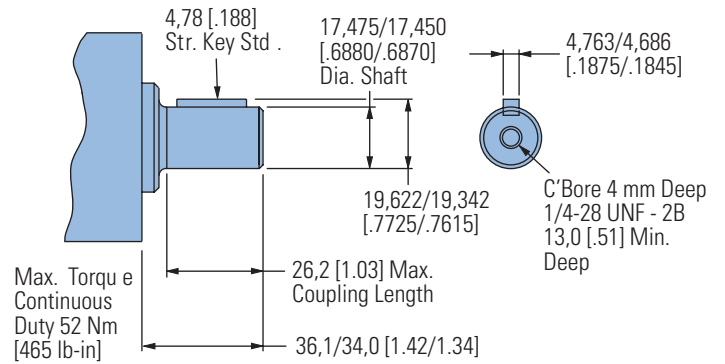

### 5/8 Inch Straight Keyed w/ Crosshole

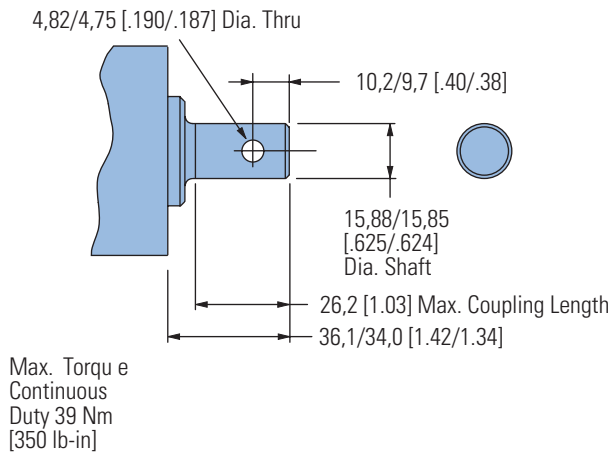

### 3/4 Inch Tapered

(Tapered Shaft End Per SAE J744)

Except as Specified — 1.5 : 12 Ratio)

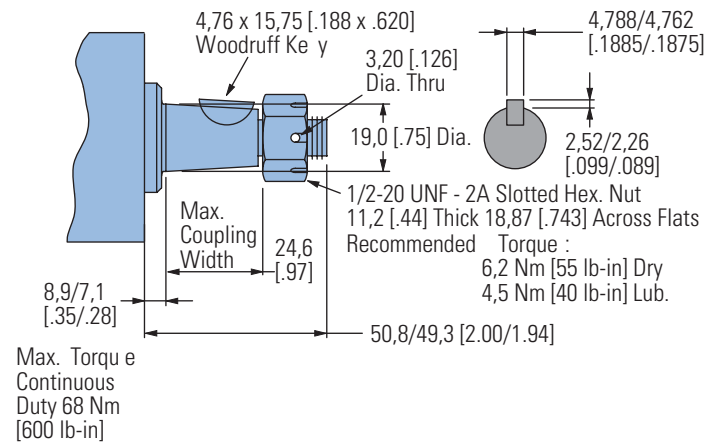

# J Series (129-)

## Dimensions

### Shafts and Flange Kit

#### 16 mm Straight Keyed

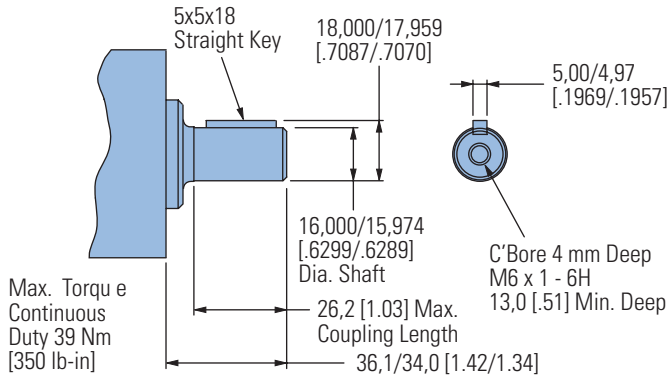

#### 18 mm Straight Keyed

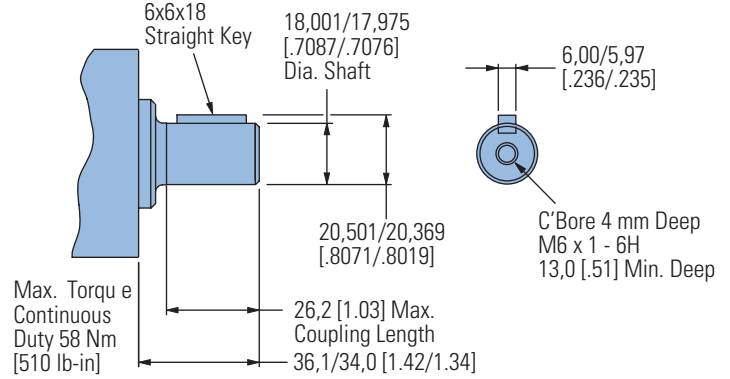

#### Involute 9T Splined – Metric

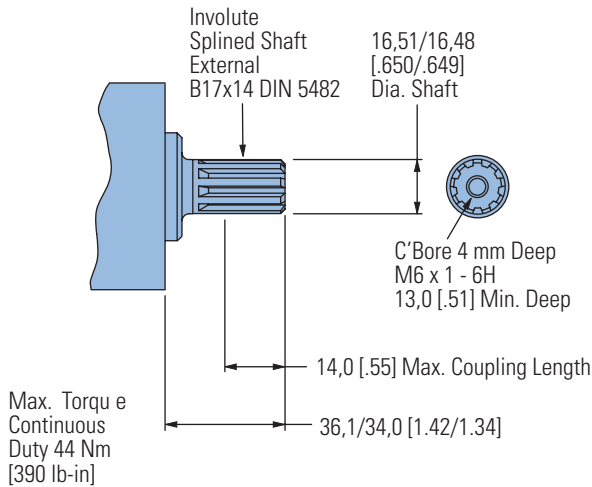

#### 2 Bolt Flange Kits (2)

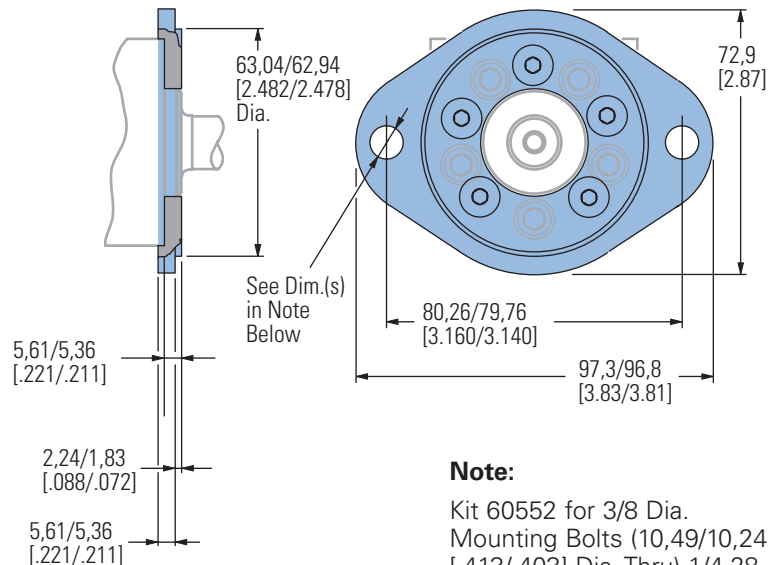

#### Note:

Kit 60552 for 3/8 Dia. Mounting Bolts (10,49/10,24 [0.413/0.403] Dia. Thru) 1/4-28 UNF screws for attaching flange to motor (5)

Kit 60553 for M8 Dia. Mounting Bolts (9,12/8,86 [0.359/0.349] Dia. Thru) M6 x 1 - 6H screws for attaching flange to motor (5)

# J Series (129-)

Product Numbers

Use digit prefix —  
129- plus four digit number  
from charts for complete  
product number—  
Example 129-0479.

**Orders will not be accepted  
without three digit prefix.**

B-1

## End Port

MOUNTING	SHAFT	PORT SIZE	DISPL. cm <sup>3</sup> /r [in <sup>3</sup> /r] / PRODUCT NUMBER				
			8,2 [.50]	12,9 [.79]	19,8 [1.21]	31,6 [1.93]	50,0 [3.00]
1/4-28 UNF 2B	5/8 inch Straight		129-0291	-0292	-0293	-0294	-0458
	11/16 inch Straight	9/16 -18 UNF 2B O-Ring (2)	129-0295	-0296	-0297	-0298	-0459
	Splined — Metric		129-0299	-0300	-0301	-0302	-0460
	3/4 inch Tapered		129-0480				
M6 x 1 - 6H	16 mm Straight	M14 x 1,5 - 6H O-Ring (2)	129-0303	-0304	-0305	-0306	-0461
	18 mm Straight		129-0307	-0308	-0309	-0310	-0462
	Splined — Metric		129-0311	-0312	-0313	-0314	-0463
	16 mm Straight	G 1/4 (BSP) (2)	129-0315	-0316	-0317	-0318	-0464
	18 mm Straight		129-0319	-0320	-0321	-0322	-0465
	Splined — Metric		129-0323	-0324	-0325	-0326	-0466
	16 mm Straight		129-0327	-0328	-0329	-0330	-0467
	18 mm Straight	G 3/8 (BSP) (2)*	129-0331	-0332	-0333	-0334	-0468
Splined — Metric	129-0335		-0336	-0337	-0338	-0469	

\*Note: The Same Casting used for Side Ports is Required for G 3/8 (BSP) End Ports

129-0336

## Side Port

MOUNTING	SHAFT	PORT SIZE	DISPL. cm <sup>3</sup> /r [in <sup>3</sup> /r] / PRODUCT NUMBER				
			8,2 [.50]	12,9 [.79]	19,8 [1.21]	31,6 [1.93]	50,0 [3.00]
1/4-28 UNF 2B	5/8 inch Straight		129-0339	-0340	-0341	-0342	-0470
	11/16 inch Straight	9/16 -18 UNF 2B O-Ring (2)	129-0343	-0344	-0345	-0346	-0471
	Splined — Metric		129-0347	-0348	-0349	-0350	-0472
	3/4 inch Tapered		129-0481				
M6 x 1 - 6H	16 mm Straight	M14 x 1,5 - 6H O-Ring (2)	129-0351	-0352	-0353	-0354	-0473
	18 mm Straight		129-0355	-0356	-0357	-0358	-0474
	Splined — Metric		129-0359	-0360	-0361	-0362	-0475
	16 mm Straight	G 1/4 (BSP) (2)	129-0363	-0364	-0365	-0366	-0476
	18 mm Straight		129-0367	-0368	-0369	-0370	-0477
	Splined — Metric		129-0371	-0372	-0373	-0374	-0403
	18 mm Straight		G 3/8 (BSP) (2)	129-0375	-0376	-0377	-0378
	Splined — Metric	129-0379		-0380	-0381	-0382	-0479

Two Bolt Mounting Flange Kit (for 3/8 inch Mounting Bolts) — Kit Number 60552 (includes 5 screws — 1/4 -28 UNF-2B)

Two Bolt Mounting Flange Kit (for M8 Mounting Bolts ) — Kit Number 60553 (includes 5 screws — M6 x 1-6H)

# J Series (129-)

## Shaft Side Load Capacity

The hydrodynamic bearing has infinite life when shaft load ratings are not exceeded. Hence, the shaft side load capacity is more than adequate to handle most externally applied loads (such as belts, chains, etc.), providing the motor to shaft size is applied within its torque rating.

Allowable side load chart, shaft load location drawing (right) and load curves (below) are based on the

side or radial loads being applied to shaft at locations A, B, and C, to determine the shaft side load capacity at locations other than those shown use the formula (shown below). For more information about shaft side loads on Char-Lynn motors contact your Eaton representative.

### ALLOWABLE SIDE LOAD – KG [LB]

RPM	A	B	C
2300	29 [ 64]	24 [ 53]	20 [ 43]
1500	44 [ 98]	37 [ 82]	30 [ 66]
1250	54 [118]	44 [ 98]	36 [ 79]
1000	67 [147]	55 [122]	45 [ 99]
750	89 [196]	74 [163]	60 [132]
600	111 [245]	93 [204]	75 [165]
500	133 [294]	111 [245]	90 [198]
400	167 [368]	139 [306]	112 [248]
340	196 [432]	163 [360]	132 [291]

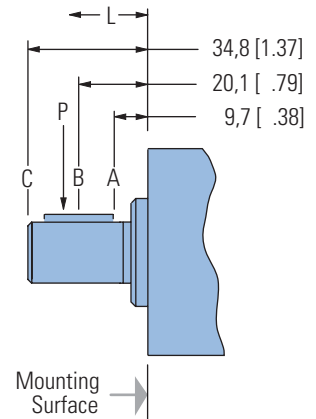
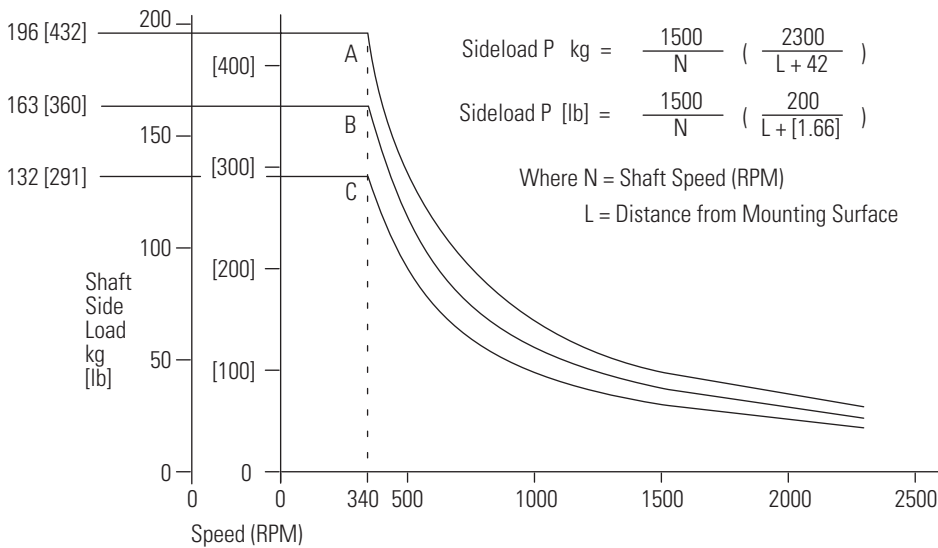

# J Series (129-)

## Case Pressure and Case Drain

The J Series now offers check valves in the motor as a standard feature. This addition reduces the case pressure in the motor to the return pressure of the system when the case drain is not used. For return pressures higher than the rated pressures (see chart) the external case drain can be connected. If the case drain line is needed, connect drain line to assure that the motor will always remain full of fluid.

### Case Drain Advantage

In addition to providing lower case pressures for motors connected in series, there are advantages for adding an external case drain line to motors with normal case pressures as well. These advantages are:

**Contamination Control** — flushing the motor case.

**Motor Cooler** — exiting oil draws motor heat away.

**Extend Motor Seal Life** — maintain low case pressure with a preset restriction installed in the case drain line

### Example:

A 14 Bar case pressure will cause a load of 40 kg, so the allowable thrust load will be 82 kg plus 40 = 120 kg pushing inward on shaft. Tension load is 82 kg under all case pressure conditions.

### Example:

A 200 PSI case pressure will cause a load of 88 lbs, so the allowable thrust load will be 180 lbs plus 88 = 268 lbs pushing inward on shaft. Tension load is 180 lb under all case pressure conditions

### Note:

J Series motors can be connected in parallel or in series.

Case pressure will add to the allowable compressive thrust load. Case pressure will push outward on the shaft at 20 kg/7 Bar [44 lb/100 PSI].

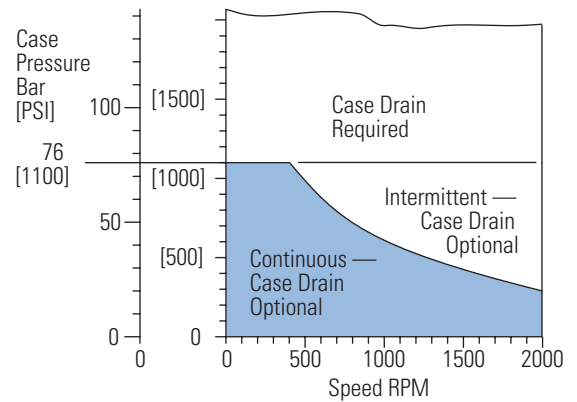
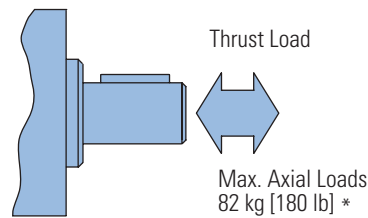
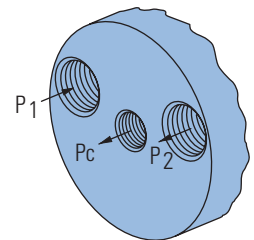

# J Series (129-)

Model Code

The following 16-digit coding system has been developed to identify all of the configuration options for the J motor. Use this model code to specify a motor with the desired features. All 16-digits of the code must be present when ordering. You may want to photocopy the matrix below to ensure that each number is entered in the correct box.

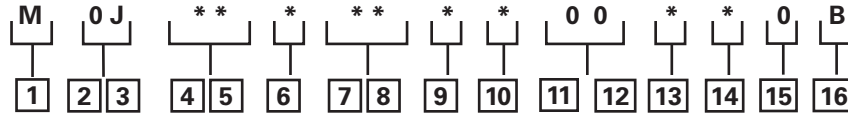

## 1 Product

**M** – Motor

## 2, 3 Series

**0J** – J Series

## 4, 5 Displacement cm<sup>3</sup>/r [in<sup>3</sup>/r]

**05** – 8,2 [ .50]

**08** – 12,9 [ .79]

**12** – 19,8 [1.21]

**19** – 31,6 [1.93]

**30** – 50,0 [3.00]

## 6 Mounting Type

**A** – 5 Bolt: Dia. 31,47 [1.239] x 5,1 [.20] Pilot 1/4-28 UNF 2B Mounting Holes on 45 [1.77] Dia. Bolt Circle

**B** – 5 Bolt: Dia. 31,47 [1.239] x 5,1 [.20] Pilot M6 x 1- 6H Mounting Holes on 45 [1.77] Dia. Bolt Circle

**C** – 2 Bolt: Dia. 62,99 [2.480] x 2,0 [.08] Pilot 10,36[.408] Mounting Holes on 80,0 [3.150] Dia. Bolt Circle

**D** – 2 Bolt: Dia. 62,99 [2.480] x 2,0 [.08] Pilot 9,0 [.354] Mounting Holes on 80,0 [3.150] Dia. Bolt Circle

## 7, 8 Output Shaft

**01** – 5/8 inch Dia. Straight with 4,72 [.186] Square Key and 1/4-28 UNF - 2B Threaded Hole

**02** – 16 mm Dia. Straight with 5,00 [.197] Square Key with M6 x 1 - 6H Threaded Hole

**04** – 11/16 inch Dia. Straight with 4,72 [.186] Square Key and 1/4-28 UNF - 2B Threaded Hole

**05** – 18 mm Dia. Straight with 5,92 [.233] Square Key with M6 x 1 - 6H Threaded Hole

**06** – Involute Splined 9T—Metric 16,50 [.650] Dia. (B17 x 14 DIN 5482) M6 x 1 - 6H Threaded Hole

**07** – 5/8 inch Dia. Straight with 4,75 [.187] Dia. Crosshole

**08** – 3/4 inch Tapered with Woodruff Key and Nut

**09** – 5/8 inch Dia. Straight with 4,72 [.186] Sq. Key with 1/4-28 UNF -2B Threaded Hole (Plated for Corrosion Protection)

**14** – 16 mm Dia. Straight with 5,00 [.197] Sq. Key with M6 x 1- 6H Threaded Hole (Plated for Corrosion Protection)

## 9 Ports

**A** – 9/16 -18 UNF - 2B O-Ring End Ported

**B** – G 1/4 (BSP) End Ported

**C** – M14 x 1,5 - 6H O-Ring Port, End Ported

**D** – 9/16 -18 UNF - 2B O-Ring Side Ported

**E** – G 3/8 (BSP) Side Ported

**F** – G 1/4 (BSP) Side Ported

**H** – G 3/8 (BSP) End Ported

## 10 Case Flow Options

**0** – No Case Drain

**1** – 3/8 -24 UNF - 2B O-Ring

**2** – G 1/8 (BSP)

**3** – M10 x 1 - 6H O-Ring

## 11, 12 Special Features (Hardware)

**00** – None

## 13 Special Features (Assembly)

**0** – None

**1** – Reverse Rotation

## 14 Paint/Special Packaging

**0** – No Paint, Individual Box

**A** – Low Gloss Black Primer, Individual Box

**B** – No Paint, Bulk Box Option

## 15 Eaton Assigned Code when Applicable

**0** – Assigned Code

## 16 Eaton Assigned Design Code

**B** – Assigned Design Code

# H Series (101-)

## Highlights

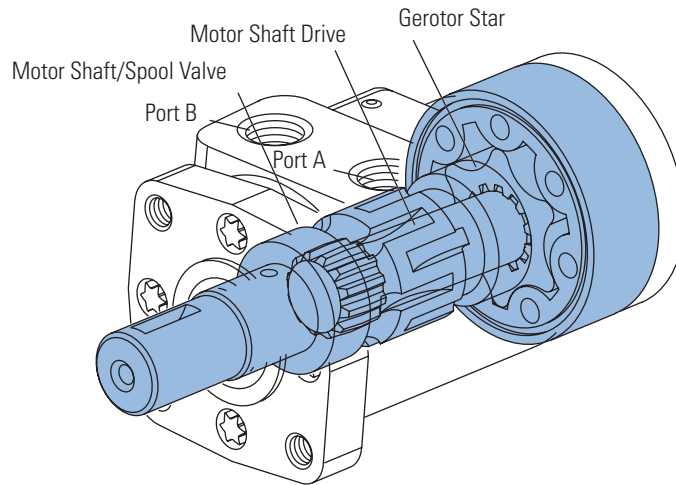

### Description

Designed for medium duty applications, these motors use industry-proven spool valve technology combined with state-of-the-art gerotors. In addition, a wide variety of mounting flanges, shafts, Ports and valving options provide design flexibility. Direction of shaft rotation and shaft speed can be controlled easily and smoothly throughout the speed range of the motor, and equipment can be driven direct, eliminating costly mechanical components.

### Specifications

Gerotor Element	13 Displacements
Flow l/min [GPM]	57 [15] Continuous***
	76 [20] Intermittent**
Speed	Up to 1100 RPM
Pressure bar [PSI]	125 [1800] Cont.***
	165 [2400] Inter.**
Torque Nm [lb-in]	407 [3604] Cont.***
	520 [4600] Inter.**

\*\*\* Continuous—(Cont.) Continuous rating, motor may be run continuously at these ratings.

\*\* Intermittent—(Inter.) Intermittent operation, 10% of every minute.

### Features:

- Time-tested Char-Lynn drive set
- Three moving components (gerotor-star, drive, and shaft)
- Optimized drive running angle
- Three-zone pressure design (inlet, return and case)
- Variety of displacements, shafts and mounts
- Special options to meet customer needs

### Benefits:

- High efficiency
- Powerful compact package
- Design flexibility
- Extended leak-free performance

### Applications:

- Agricultural augers, harvesters, seeders
- Car wash brushes
- Food processing
- Railroad maintenance equipment
- Machine tools
- Conveyors
- Industrial sweepers and floor polishers
- Saw mill works
- Turf equipment
- Concrete and asphalt equipment
- Skid steer attachments
- Many more

B-2



Conveyer



Combine



Sweeper



Salt and Sand Spreader

# H Series (101-)

## Specifications

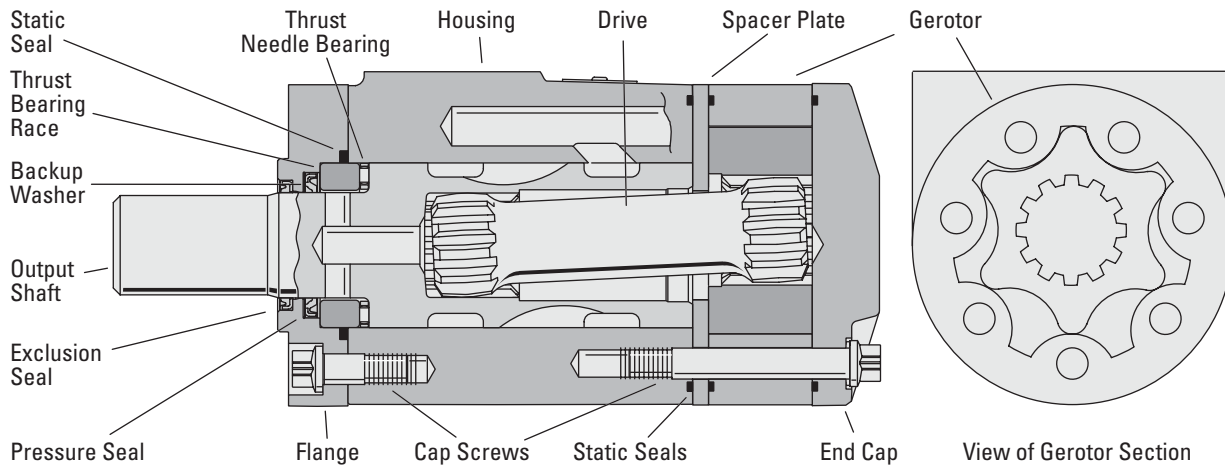

### SPECIFICATION DATA – H MOTORS

Displ. cm <sup>3</sup> /r [in <sup>3</sup> /r]		36 [2.2]	46 [2.8]	59 [3.6]	74 [4.5]	97 [5.9]	120 [7.3]	146 [8.9]	159 [9.7]	185 [11.3]	231 [14.1]	293 [17.9]	370 [22.6]	739 [45.1]
Max. Speed (RPM) @ Continuous Flow		1021	969	953	760	585	469	385	353	304	243	192	152	74
Flow LPM [GPM]	Continuous	38 [10]	45 [12]	57 [15]	57 [15]	57 [15]	57 [15]	57 [15]	57 [15]	57 [15]	57 [15]	57 [15]	57 [15]	57 [15]
	Intermittent	38 [10]	53 [14]	64 [17]	68 [18]	68 [18]	76 [20]	76 [20]	76 [20]	76 [20]	76 [20]	76 [20]	76 [20]	76 [20]
Torque Nm [lb-in]	Continuous	56 [497]	73 [650]	91 [802]	118 [1044]	155 [1368]	192 [1699]	221 [1954]	233 [2059]	265 [2343]	302 [2669]	351 [3110]	407 [3604]	389 [3440]
	Intermittent	75 [668]	99 [876]	122 [1076]	158 [1401]	207 [1829]	257 [2278]	300 [2653]	319 [2824]	356 [3151]	415 [3671]	466 [4121]	484 [4283]	520 [4600]
Min. Starting Torque @ Int. Pressure	@ Cont. Pressure	46 [410]	59 [520]	76 [670]	95 [840]	124 [1100]	154 [1360]	176 [1560]	186 [1650]	211 [1870]	238 [2110]	282 [2500]	330 [2920]	316 [2800]
	@ Int. Pressure	63 [560]	81 [720]	104 [920]	130 [1150]	171 [1510]	2102 [1860]	46 [2180]	262 [2320]	293 [2590]	339 [3000]	388 [3430]	408 [3610]	434 [3840]
Pressure ΔBar [Δ PSI]	Continuous	124 [1800]	124 [1800]	124 [1800]	124 [1800]	124 [1800]	124 [1800]	117 [1700]	114 [1650]	110 [1600]	100 [1450]	93 [1350]	86 [1250]	41 [600]
	Intermittent	165 [2400]	165 [2400]	165 [2400]	165 [2400]	165 [2400]	165 [2400]	159 [2300]	155 [2250]	148 [2150]	138 [2000]	124 [1800]	103 [1500]	55 [800]
End Ported Units Only														
Δ Bar [Δ PSI]	Cont. Pressure	83 [1200]	83 [1200]	76 [1100]	76 [1100]	76 [1100]	69 [1000]	69 [1000]	69 [1000]	62 [900]	55 [800]	48 [700]	57 [825]	27 [396]
	Intermittent	117 [1700]	117 [1700]	110 [1600]	110 [1600]	110 [1600]	103 [1500]	103 [1500]	103 [1500]	91 [1400]	90 [1300]	83 [1200]	68 [990]	36 [528]
Weight kg [lb]		5,1 [11.2]	5,1 [11.2]	5,2 [11.5]	5,2 [11.5]	5,4 [11.8]	5,5 [12.1]	5,6 [12.4]	5,7 [12.5]	5,8 [12.8]	6,0 [13.3]	6,3 [14.0]	6,7 [14.7]	8,4 [18,6]

A simultaneous maximum torque and maximum speed NOT recommended.

#### Note:

To assure best motor life, run motor for approximately one hour at 30% of rated pressure before application to full load. Be sure motor is filled with fluid prior to any load applications.

#### Note:

Δ pressure is derated for end ported units.

#### Maximum Inlet Pressure:

172 Bar [2500 PSI] without regard to Δ Bar [Δ PSI] and/or back pressure ratings or combination thereof.

6B splined or Tapered shafts are recommended whenever operation above 282 NM [2500 lb-in] of torque, especially for those applications subject to frequent reversals.

#### Δ Pressure:

The true Δ bar [Δ PSI] difference between inlet port and outlet port

#### Continuous Rating:

Motor may be run continuously at these ratings

#### Intermittent Operation:

10% of every minute

#### Recommended Fluids:

Recommended Fluids — Premium quality, anti-wear type hydraulic oil. Minimum oil viscosity (at operating temperature) should be the highest of the following:

$$100 \text{ SUS or } \left[ \frac{300 \times \text{Bar}}{\text{RPM}} = \text{SUS} \right]$$

$$\frac{20 \times \text{PSI}}{\text{RPM}} = \text{SUS} \right]$$

#### Recommended System Operating Temp.:

-34°C to 82°C [-30°F to 180°F]

#### Recommended Filtration:

per ISO Cleanliness Code 4406, level 20/18/13



# H Series (101-)

## Performance Data

Motors run with high efficiency in all areas designated with a number for torque and speed, however for best motor life select a motor to run with a torque and speed range printed in the light shaded area.

Performance data is typical at 120 SUS. Actual data may vary slightly from unit to unit in production.

Continuous  
 Intermittent

36 cm<sup>3</sup>/r [2.2 in<sup>3</sup>/r]  
Δ Pressure Bar [PSI]  
Continuous

	[200] 14	[400] 28	[600] 41	[800] 55	[1000] 69	[1200] 83	[1400] 97	[1600] 110	[1800] 124	Max. Contin- uous	Max. Inter- mittent
<b>Flow LPM [GPM]</b>	[2] 7,6	[49] 6 204	[103] 12 201	[162] 18 198	[189] 21 194	[270] 31 189	[325] 37 184	[379] 43 177	[432] 49 170	[489] 55 162	[650] 73 122
	[4] 15,1	[47] 5 408	[106] 12 407	[160] 18 402	[191] 22 399	[274] 31 394	[327] 37 387	[384] 43 381	[439] 50 373	[495] 56 365	[654] 74 323
	[6] 22,7	[44] 5 613	[102] 12 612	[158] 18 609	[188] 21 604	[272] 31 599	[328] 37 591	[383] 43 586	[440] 50 576	[496] 56 565	[661] 75 523
	[8] 30,3	[40] 5 817	[97] 11 817	[153] 17 814	[184] 21 807	[270] 31 799	[326] 37 793	[383] 43 785	[440] 50 776	[497] 56 762	[668] 75 721
<b>Max. Contin- uous</b>	[10] 4 1021	[90] 10 1021	[148] 17 1015	[180] 20 1008	[265] 30 1001	[322] 36 991	[380] 43 981	[438] 49 969	[495] 56 959	[664] 75 920	

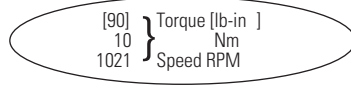

46 cm<sup>3</sup>/r [2.8 in<sup>3</sup>/r]  
Δ Pressure Bar [PSI]  
Continuous

	[200] 14	[400] 28	[600] 41	[800] 55	[1000] 69	[1200] 83	[1400] 97	[1600] 110	[1800] 124	Max. Contin- uous	Max. Inter- mittent
<b>Flow LPM [GPM]</b>	[2] 7,6	[64] 7 161	[136] 15 158	[212] 24 156	[284] 32 153	[355] 40 148	[426] 48 145	[497] 56 139	[567] 64 133	[641] 72 127	[852] 96 95
	[4] 15,1	[61] 7 323	[139] 16 320	[209] 24 316	[286] 32 314	[359] 41 310	[429] 48 304	[503] 57 300	[576] 65 293	[649] 73 287	[857] 97 253
	[6] 22,7	[58] 7 486	[134] 15 481	[207] 23 479	[282] 32 475	[356] 40 471	[430] 49 464	[502] 57 461	[577] 65 453	[650] 73 444	[867] 98 410
	[8] 30,3	[52] 6 648	[128] 14 643	[200] 23 640	[276] 31 635	[354] 40 628	[428] 48 623	[502] 57 617	[577] 65 610	[651] 74 599	[876] 99 566
<b>Max. Contin- uous</b>	[10] 5 808	[47] 13 803	[118] 22 798	[194] 30 793	[269] 38 787	[347] 47 779	[423] 56 771	[498] 65 761	[575] 73 753	[649] 81 722	[871] 98 722
<b>Max. Inter- mittent</b>	[14] 3 1127	[25] 11 1123	[98] 20 1115	[175] 28 1108	[249] 37 1100	[327] 46 1093	[404] 55 1086	[484] 63 1079	[559] 72 1068	[634] 81 1068	[864] 98 877

# H Series (101-)

## Performance Data

Motors run with high efficiency in all areas designated with a number for torque and speed, however for best motor life select a motor to run with a torque and speed range printed in the light shaded area.

Performance data is typical at 120 SUS. Actual data may vary slightly from unit to unit in production.

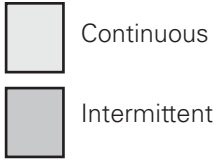

		59 cm <sup>3</sup> /r [3.6 in <sup>3</sup> /r] Pressure Bar [PSI] Continuous									Max. Continuous	Max. Intermittent
		[200]	[400]	[600]	[800]	[1000]	[1200]	[1400]	[1600]	[1800]	[2400]	[1800]
		14	28	41	55	69	83	97	110	124	165	124
Flow LPM [GPM]	[2]	[79]	[169]	[260]	[305]	[437]	[526]	[616]	[704]	[796]	[1055]	[1055]
	7.6	9 127	19 125	29 123	34 121	49 117	59 114	70 109	80 103	90 96	119 65	119 65
	[4]	[76]	[168]	[257]	[307]	[441]	[529]	[620]	[710]	[800]	[1065]	[1065]
	15.1	9 254	19 254	29 251	35 249	50 246	60 241	70 236	80 230	90 224	120 193	120 193
	[6]	[73]	[161]	[252]	[303]	[439]	[529]	[618]	[709]	[802]	[1069]	[1069]
	22.7	8 381	18 381	28 380	34 377	50 373	60 368	70 364	80 358	91 349	121 319	121 319
	[8]	[64]	[151]	[243]	[294]	[428]	[519]	[609]	[701]	[794]	[1076]	[1076]
	30.3	7 508	17 508	27 508	33 504	48 500	59 496	69 491	79 484	90 476	122 446	122 446
	[10]	[57]	[141]	[234]	[283]	[419]	[512]	[602]	[693]	[786]	[1071]	[1071]
	37.9	6 635	16 635	26 634	32 630	47 626	58 621	68 614	78 614	89 608	121 601	121 601
[12]	[45]	[131]	[227]	[274]	[409]	[505]	[593]	[684]	[778]	[1058]	[1058]	
45.4	5 762	15 762	26 762	31 757	46 753	57 747	67 741	77 734	88 728	120 694	120 694	
[14]	[33]	[118]	[213]	[266]	[396]	[492]	[583]	[676]	[770]	[1055]	[1055]	
53.0	4 889	13 889	24 887	30 882	45 877	56 872	66 866	76 860	87 851	119 813	119 813	
[15]	[29]	[111]	[205]	[260]	[389]	[486]	[576]	[670]	[765]	[1055]	[1055]	
56.8	3 953	13 953	23 951	29 945	44 940	55 935	65 929	76 921	86 913	119 872	119 872	
Max. Continuous	[20]	[17]	[98]	[192]	[252]	[377]	[475]	[567]	[660]	[757]		
75.7	2 1080	11 1080	22 1077	28 1071	43 1067	54 1062	64 1055	75 1049	86 1040			

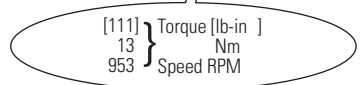

		74 cm <sup>3</sup> /r [4.5 in <sup>3</sup> /r] Pressure Bar [PSI] Continuous									Max. Continuous	Max. Intermittent
		[200]	[400]	[600]	[800]	[1000]	[1200]	[1400]	[1600]	[1800]	[2400]	[1800]
		14	28	41	55	69	83	97	110	124	165	124
Flow LPM [GPM]	[2]	[103]	[220]	[339]	[454]	[569]	[685]	[801]	[916]	[1036]	[1373]	[1373]
	7.6	12 101	25 99	38 98	51 96	64 93	77 90	91 86	103 81	117 76	155 51	155 51
	[4]	[99]	[219]	[335]	[457]	[574]	[689]	[808]	[925]	[1042]	[1386]	[1386]
	15.1	11 203	25 201	38 199	52 197	65 194	78 191	91 187	105 182	118 177	157 153	157 153
	[6]	[94]	[210]	[328]	[451]	[571]	[689]	[805]	[924]	[1044]	[1392]	[1392]
	22.7	11 305	24 303	37 301	51 298	65 296	78 292	91 288	104 283	118 276	157 252	157 252
	[8]	[86]	[196]	[319]	[438]	[558]	[676]	[793]	[913]	[1033]	[1401]	[1401]
	30.3	10 406	22 404	36 402	49 399	63 396	76 393	90 388	103 383	117 377	158 352	158 352
	[10]	[74]	[183]	[310]	[422]	[545]	[667]	[784]	[903]	[1024]	[1394]	[1394]
	37.9	8 507	21 505	35 502	48 499	62 496	75 492	89 486	102 482	116 476	158 452	158 452
[12]	[58]	[171]	[295]	[408]	[533]	[657]	[773]	[891]	[1013]	[1377]	[1377]	
45.4	7 608	19 606	33 603	46 600	60 596	74 591	87 587	101 581	114 576	156 549	156 549	
[14]	[43]	[154]	[277]	[396]	[515]	[640]	[760]	[880]	[1002]	[1374]	[1374]	
53.0	5 709	17 706	31 702	45 698	58 694	72 691	86 686	99 681	113 674	155 643	155 643	
[15]	[36]	[145]	[268]	[387]	[506]	[632]	[750]	[873]	[996]	[1373]	[1373]	
56.8	4 760	16 757	30 753	44 749	57 744	71 740	85 735	99 729	113 723	155 690	155 690	
Max. Continuous	[20]	[14]	[121]	[233]	[351]	[482]	[609]	[725]	[856]	[981]		
75.7	2 904	14 902	26 898	40 895	54 891	69 887	82 882	97 877	111 869			

# H Series (101-)

## Performance Data

Motors run with high efficiency in all areas designated with a number for torque and speed, however for best motor life select a motor to run with a torque and speed range printed in the light shaded area.

Performance data is typical at 120 SUS. Actual data may vary slightly from unit to unit in production.

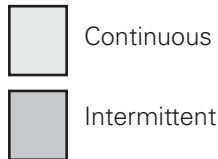

		97 cm <sup>3</sup> /r [5.9 in <sup>3</sup> /r] Δ Pressure Bar [PSI] Continuous										Max. Continuous	Max. Intermittent
		[200]	[400]	[600]	[800]	[1000]	[1200]	[1400]	[1600]	[1800]	[2400]		
		14	28	41	55	69	83	97	110	124	165		
Flow LPM [GPM]	[2] 7,6	[134] 15 78	[292] 33 76	[442] 50 75	[593] 67 73	[746] 84 71	[899] 102 68	[1054] 119 65	[1209] 137 61	[1365] 154 55	[1806] 204 33		
	[4] 15,1	[131] 15 156	[281] 32 155	[436] 49 153	[596] 67 151	[750] 85 149	[903] 102 147	[1059] 120 143	[1212] 137 139	[1367] 154 134	[1828] 207 113		
	[6] 22,7	[126] 14 234	[269] 30 233	[425] 48 231	[588] 66 230	[747] 84 228	[900] 102 224	[1054] 119 221	[1206] 136 217	[1368] 155 210	[1823] 206 189		
	[8] 30,3	[110] 12 312	[246] 28 311	[408] 46 310	[566] 64 308	[718] 81 305	[873] 99 303	[1023] 116 300	[1177] 133 295	[1339] 151 291	[1829] 207 269		
	[10] 37,9	[96] 11 390	[231] 26 389	[392] 44 387	[539] 61 385	[699] 79 383	[859] 97 380	[1005] 114 376	[1156] 131 373	[1318] 149 368	[1821] 206 346		
	[12] 45,4	[77] 9 468	[218] 25 467	[378] 43 465	[522] 59 463	[681] 77 460	[844] 95 457	[990] 112 453	[1142] 129 449	[1301] 147 445	[1792] 202 421		
	[14] 53,0	[60] 7 546	[197] 22 544	[358] 40 542	[513] 58 539	[662] 75 537	[828] 94 535	[973] 110 531	[1131] 128 526	[1293] 146 521	[1776] 201 499		
	Max. Continuous 56,8	[52] 6 585	[189] 21 583	[346] 39 581	[495] 56 578	[651] 74 575	[819] 93 573	[963] 109 569	[1126] 127 564	[1286] 145 559	[1778] 201 536		
	Max. Intermittent 75,7	[25] 3 701	[157] 18 700	[311] 35 697	[455] 51 694	[625] 71 691	[790] 89 688	[941] 106 684	[1110] 125 681	[1272] 144 674			



		120 cm <sup>3</sup> /r [7.3 in <sup>3</sup> /r] Δ Pressure Bar [PSI] Continuous										Max. Continuous	Max. Intermittent
		[200]	[400]	[600]	[800]	[1000]	[1200]	[1400]	[1600]	[1800]	[2400]		
		14	28	41	55	69	83	97	110	124	165		
Flow LPM [GPM]	[2] 7,6	[162] 18 62	[357] 40 61	[544] 61 61	[736] 83 59	[927] 105 58	[1116] 126 55	[1305] 147 53	[1498] 169 49	[1687] 191 45	[2231] 252 26		
	[4] 15,1	[160] 18 125	[348] 39 124	[539] 61 123	[736] 83 121	[930] 105 120	[1119] 126 119	[1316] 149 116	[1506] 170 114	[1698] 192 110	[2268] 256 90		
	[6] 22,7	[155] 18 188	[338] 38 187	[530] 60 186	[729] 82 185	[923] 104 183	[1116] 126 180	[1310] 148 178	[1500] 169 175	[1699] 192 170	[2271] 257 152		
	[8] 30,3	[139] 16 250	[319] 36 250	[515] 58 249	[710] 80 247	[901] 102 245	[1094] 124 243	[1283] 145 241	[1476] 167 237	[1673] 189 233	[2278] 257 216		
	[10] 37,9	[121] 14 313	[303] 34 312	[497] 56 311	[686] 78 309	[883] 100 308	[1081] 122 306	[1267] 143 302	[1460] 165 300	[1655] 187 296	[2268] 256 278		
	[12] 45,4	[102] 12 375	[288] 33 374	[480] 54 373	[664] 75 371	[862] 97 370	[1060] 120 367	[1246] 141 365	[1440] 163 361	[1640] 185 358	[2232] 252 338		
	[14] 53,0	[78] 9 438	[263] 30 437	[458] 52 435	[652] 74 433	[841] 95 431	[1041] 118 430	[1228] 139 427	[1420] 160 423	[1616] 183 419	[2213] 250 401		
	Max. Continuous 56,8	[67] 8 469	[253] 29 468	[446] 50 466	[632] 71 464	[828] 94 462	[1030] 116 460	[1214] 137 458	[1411] 159 454	[1608] 182 450	[2205] 249 430		
	Max. Intermittent 75,7	[20] 2 626	[202] 23 624	[384] 43 621	[581] 66 618	[778] 88 617	[971] 110 614	[1169] 132 611	[1356] 153 609	[1559] 176 606			

# H Series (101-)

## Performance Data

Motors run with high efficiency in all areas designated with a number for torque and speed, however for best motor life select a motor to run with a torque and speed range printed in the light shaded area.

Performance data is typical at 120 SUS. Actual data may vary slightly from unit to unit in production.

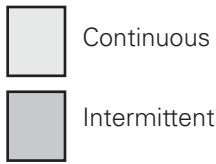

		146 cm <sup>3</sup> /r [8.9 in <sup>3</sup> /r] Δ Pressure Bar [PSI] Continuous									Max. Continuous	Max. Intermittent
		[200]	[400]	[600]	[800]	[1000]	[1200]	[1400]	[1600]	[1700]	[2300]	
		14	28	41	55	69	83	97	110	117	159	
Flow LPM [GPM]	[2] 7,6	[198] 22 51	[435] 49 50	[664] 75 50	[897] 101 49	[1130] 128 47	[1361] 154 45	[1591] 180 43	[1827] 206 40	[1942] 219 39	[2611] 295 24	
	[4] 15,1	[196] 22 103	[424] 48 102	[657] 74 101	[898] 101 99	[1133] 128 99	[1365] 154 97	[1604] 181 95	[1836] 207 93	[1954] 221 92	[2648] 299 78	
	[6] 22,7	[189] 21 154	[412] 47 153	[646] 73 152	[889] 100 151	[1125] 127 150	[1361] 154 148	[1598] 181 146	[1829] 207 143	[1951] 220 141	[2653] 300 128	
	[8] 30,3	[169] 19 205	[389] 44 205	[628] 71 204	[866] 98 203	[1098] 124 201	[1333] 151 200	[1564] 177 197	[1799] 203 195	[1919] 217 193	[2649] 299 180	
	[10] 37,9	[148] 17 257	[369] 42 256	[605] 68 255	[836] 94 253	[1076] 122 252	[1318] 149 251	[1544] 174 248	[1780] 201 246	[1899] 215 244	[2789] 315 231	
	[12] 45,4	[125] 14 308	[351] 40 307	[586] 66 306	[810] 92 305	[1051] 119 303	[1293] 146 301	[1519] 172 299	[1756] 198 296	[1878] 212 295	[2606] 294 281	
	[14] 53,0	[95] 11 359	[321] 36 358	[558] 63 357	[795] 90 355	[1026] 116 354	[1290] 146 352	[1497] 169 350	[1731] 196 347	[1851] 209 346	[2580] 292 331	
	Max. Continuous 56,8	[82] 9 85	[308] 35 384	[544] 61 383	[771] 87 381	[1010] 114 379	[1256] 142 378	[1480] 167 375	[1720] 194 373	[1840] 208 371	[2569] 290 356	
	Max. Intermittent 75,7	[24] 3 513	[246] 28 512	[468] 53 509	[708] 80 507	[948] 107 506	[1184] 134 504	[1425] 161 501	[1653] 187 499	[1780] 201 498		

		159 cm <sup>3</sup> /r [9.7 in <sup>3</sup> /r] Δ Pressure Bar [PSI] Continuous									Max. Continuous	Max. Intermittent
		[200]	[400]	[600]	[800]	[1000]	[1200]	[1400]	[1600]	[1650]	[2250]	
		14	28	41	55	69	83	97	110	134	155	
Flow LPM [GPM]	[2] 7,6	[209] 24 47	[465] 53 46	[715] 81 46	[973] 110 45	[1228] 139 44	[1478] 167 42	[1724] 195 40	[1981] 224 38	[2046] 231 37	[2764] 312 23	
	[4] 15,1	[210] 24 94	[460] 52 94	[710] 80 93	[971] 110 91	[1229] 139 91	[1480] 167 90	[1745] 197 89	[1996] 226 87	[2059] 233 87	[2813] 318 76	
	[6] 22,7	[205] 23 141	[454] 51 141	[704] 80 140	[965] 109 139	[1216] 137 138	[1477] 167 136	[1738] 196 134	[1991] 225 132	[2055] 232 132	[2824] 319 119	
	[8] 30,3	[186] 21 188	[440] 50 188	[693] 78 187	[951] 107 186	[1205] 136 185	[1461] 165 183	[1716] 194 181	[1973] 223 179	[2038] 230 178	[2808] 317 166	
	[10] 37,9	[164] 19 235	[422] 48 234	[671] 76 234	[930] 105 232	[1189] 134 232	[1451] 164 230	[1702] 192 228	[1965] 219 226	[2032] 230 225	[2789] 315 213	
	[12] 45,4	[144] 16 282	[404] 46 281	[652] 74 281	[900] 102 279	[1163] 131 279	[1421] 161 277	[1674] 189 275	[1937] 219 273	[2004] 226 272	[2770] 313 260	
	[14] 53,0	[109] 12 330	[374] 42 329	[623] 70 328	[883] 100 327	[1140] 129 325	[1396] 158 323	[1653] 187 322	[1900] 215 319	[1963] 222 319	[2727] 308 306	
	Max. Continuous 56,8	[92] 10 353	[359] 41 352	[612] 69 351	[861] 97 350	[1123] 127 348	[1381] 156 347	[1633] 185 345	[1886] 213 343	[1950] 220 342	[2712] 306 330	
	Max. Intermittent 75,7	[26] 3 471	[268] 30 470	[510] 58 467	[772] 87 465	[1034] 117 464	[1290] 146 462	[1553] 175 460	[1802] 204 458	[1865] 211 458		



# H Series (101-)

## Performance Data

Motors run with high efficiency in all areas designated with a number for torque and speed, however for best motor life select a motor to run with a torque and speed range printed in the light shaded area.

Performance data is typical at 120 SUS. Actual data may vary slightly from unit to unit in production.

	Continuous
	Intermittent

		185 cm <sup>3</sup> /r [11.3 in <sup>3</sup> /r]								Max. Contin-	Max. Inter-
		Δ Pressure Bar [PSI]								uous	mittent
		Continuous									
		[200]	[400]	[600]	[800]	[1000]	[1200]	[1400]	[1600]		
		14	28	41	55	69	83	97	110	[2150]	148
Flow LPM [GPM]	[2]	[257]	[554]	[847]	[1150]	[1447]	[1739]	[2035]	[2320]	[3103]	
	7,6	29 40	63 40	96 39	130 38	163 37	196 36	230 33	262 29	351 12	
	[4]	[254]	[546]	[845]	[1145]	[1448]	[1744]	[2049]	[2343]	[3147]	
	15,1	29 81	62 81	95 80	129 79	164 78	197 77	232 76	265 74	356 63	
	[6]	[246]	[540]	[834]	[1137]	[1434]	[1736]	[2036]	[2337]	[3151]	
	22,7	28 121	61 121	94 120	128 120	162 119	196 117	230 115	264 112	356 100	
	[8]	[224]	[520]	[820]	[1117]	[1414]	[1716]	[2014]	[2315]	[3133]	
	30,3	25 162	59 162	93 161	126 160	160 159	194 157	228 155	262 152	354 140	
	[10]	[202]	[499]	[793]	[1095]	[1394]	[1699]	[1997]	[2299]	[3112]	
	37,9	23 202	56 202	90 201	124 201	158 200	192 198	226 196	260 193	352 181	
[12]	[176]	[475]	[767]	[1063]	[1368]	[1664]	[1969]	[2268]	[3088]		
45,4	20 243	54 242	87 242	120 241	155 240	188 238	222 236	256 234	349 222		
[14]	[140]	[443]	[735]	[1035]	[1340]	[1637]	[1936]	[2227]	[3051]		
53,0	16 283	50 283	83 282	117 281	151 280	185 279	219 277	252 274	345 262		
Max. Contin-uous	[15]	[120]	[425]	[719]	[1014]	[1320]	[1618]	[1914]	[2205]	[3023]	
	56,8	14 304	48 303	81 302	115 301	149 300	183 299	216 297	249 294	342 283	
Max. Inter-mittent	[20]	[27]	[321]	[612]	[911]	[1211]	[1504]	[1795]			
	75,7	3 405	36 404	69 402	103 401	137 400	170 398	203 397			

		231 cm <sup>3</sup> /r [14.1 in <sup>3</sup> /r]								Max. Contin-	Max. Inter-
		Δ Pressure Bar [PSI]								uous	mittent
		Continuous									
		[200]	[400]	[600]	[800]	[1000]	[1200]	[1400]	[1450]	[2000]	138
		14	28	41	55	69	83	97	100		
Flow LPM [GPM]	[2]	[338]	[707]	[1074]	[1456]	[1827]	[2192]	[2572]	[2657]		
	7,6	38 32	80 32	121 31	165 30	206 30	248 28	291 26	300 25		
	[4]	[328]	[695]	[1076]	[1447]	[1827]	[2201]	[2577]	[2669]	[3671]	
	15,1	37 65	79 65	122 64	163 63	206 62	249 62	291 60	302 60	415 50	
	[6]	[317]	[687]	[1057]	[1434]	[1811]	[2186]	[2555]	[2650]	[3668]	
	22,7	36 97	78 97	119 97	162 96	205 95	247 94	289 92	299 91	414 80	
	[8]	[289]	[659]	[1038]	[1406]	[1777]	[2160]	[2531]	[2625]	[3644]	
	30,3	33 130	74 130	117 130	159 129	201 128	244 127	286 124	297 124	412 112	
	[10]	[265]	[631]	[1004]	[1381]	[1751]	[2131]	[2510]	[2602]	[3608]	
	37,9	30 162	71 162	113 162	156 162	198 160	241 158	284 156	294 156	408 145	
[12]	[230]	[599]	[968]	[1345]	[1722]	[2088]	[2480]	[2571]	[3571]		
45,4	26 195	68 195	109 194	152 194	195 193	236 192	280 189	290 189	403 178		
[14]	[191]	[563]	[927]	[1299]	[1686]	[2058]	[2428]	[2519]	[3532]		
53,0	22 227	64 227	105 227	147 226	190 226	233 224	274 222	285 221	399 212		
Max. Contin-uous	[15]	[167]	[538]	[904]	[1279]	[1661]	[2030]	[2404]	[2493]	[3488]	
	56,8	19 243	61 243	102 243	145 242	188 242	229 240	272 238	282 238	394 229	
Max. Inter-mittent	[20]	[29]	[411]	[785]	[1152]	[1520]	[1877]	[2222]	[2318]		
	75,7	3 324	46 324	89 323	130 322	172 322	212 320	251 319	262 318		

[538] } Torque [lb-in ]  
61 } Nm  
243 } Speed RPM

# H Series (101-)

## Performance Data

Motors run with high efficiency in all areas designated with a number for torque and speed, however for best motor life select a motor to run with a torque and speed range printed in the light shaded area.

Performance data is typical at 120 SUS. Actual data may vary slightly from unit to unit in production.

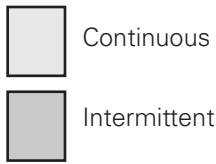

		293 cm <sup>3</sup> /r [17.9 in <sup>3</sup> /r]						Max. Continuous	Max. Intermittent
		Δ Pressure Bar [PSI]							
		[200]	[400]	[600]	[800]	[1000]	[1200]	[1350]	[1800]
		14	28	41	55	69	83	93	124
Flow LPM [GPM]	[2]	[427]	[893]	[1361]	[1829]	[2293]	[2672]	[2977]	
	7,6	48 26	101 25	154 25	207 24	259 22	302 16	336 13	
	[4]	[419]	[886]	[1362]	[1833]	[2305]	[2771]	[3110]	[4107]
	15,1	47 51	100 51	154 51	207 50	260 49	313 47	351 44	464 22
	[6]	[402]	[872]	[1342]	[1819]	[2291]	[2757]	[3098]	[4121]
	22,7	45 77	99 77	152 76	206 76	259 74	312 71	350 68	466 54
	[8]	[367]	[838]	[1316]	[1785]	[2252]	[2723]	[3070]	[4086]
	30,3	41 102	95 102	149 102	202 101	254 100	308 98	347 95	462 84
	[10]	[332]	[803]	[1276]	[1749]	[2215]	[2684]	[3034]	[4061]
	37,9	38 128	91 128	144 128	198 127	250 126	303 123	343 120	459 108
[12]	[289]	[760]	[1230]	[1706]	[2177]	[2634]	[2989]	[4012]	
45,4	33 153	86 153	139 153	193 153	246 151	298 149	338 146	453 135	
[14]	[241]	[712]	[1176]	[1650]	[2126]	[2592]	[2935]	[3963]	
53,0	27 179	80 179	133 179	186 179	240 177	293 175	332 172	448 161	
Max. Continuous	[15]	[211]	[683]	[1149]	[1623]	[2096]	[2558]	[2905]	[3914]
	56,8	24 192	77 192	130 192	183 191	237 190	289 188	328 174	442 174
Max. Intermittent	[20]	[43]	[527]	[1001]	[1463]	[1919]	[2375]	[2720]	
	75,7	5 256	60 256	113 255	165 255	217 254	268 252	307 249	

		370 cm <sup>3</sup> /r [22.6 in <sup>3</sup> /r]						Max. Continuous	Max. Intermittent			739 cm <sup>3</sup> /r [45.1 in <sup>3</sup> /r]			Max. Continuous	Max. Intermittent	
		Δ Pressure Bar [PSI]										Δ Pressure Bar [PSI]					
		[200]	[400]	[600]	[800]	[1000]	[1200]	[1250]	[1500]			[200]	[400]	[600]	[800]		
		14	28	41	55	69	83	86	103			14	28	41	55		
Flow LPM [GPM]	[2]	[537]	[1121]	[1715]	[2285]	[2862]						[2]	[1080]	[2250]	[3440]	[4570]	
	7,6	61 20	127 20	194 20	258 19	323 16						7,6	122 10	254 10	389 10	516 9	
	[4]	[532]	[1123]	[1715]	[2308]	[2893]	[3467]	[3604]	[4274]			[4]	[1070]	[2250]	[3440]	[4600]	
	15,1	60 40	127 40	194 40	261 39	327 38	392 36	407 35	483 27			15,1	121 20	254 20	389 19	520 18	
	[6]	[508]	[1100]	[1693]	[2294]	[2884]	[3458]	[3598]	[4283]			[6]	[1020]	[2200]	[3390]	[4590]	
	22,7	57 61	124 61	191 61	259 60	326 58	391 55	407 53	484 47			22,7	115 30	249 30	383 29	519 27	
	[8]	[463]	[1060]	[1661]	[2255]	[2840]	[3414]	[3557]	[4254]			[8]	[ 945]	[2135]	[3330]	[4515]	
	30,3	52 81	120 81	188 81	255 80	321 79	386 76	402 74	481 68			30,3	107 40	241 40	376 39	510 37	
	[10]	[414]	[1017]	[1613]	[2203]	[2788]	[3363]	[3506]	[4212]			[10]	[ 840]	[2050]	[3250]	[4430]	
	37,9	47 101	115 101	182 101	249 101	315 99	380 96	396 94	476 88			37,9	95 50	232 50	367 48	501 46	
[12]	[363]	[960]	[1553]	[2152]	[2737]	[3305]	[3446]	[4152]			[12]	[ 740]	[1945]	[3130]	[4320]		
45,4	41 121	108 121	175 121	243 121	309 119	373 116	389 115	469 109			45,4	84 60	220 59	354 58	488 55		
[14]	[303]	[897]	[1484]	[2086]	[2667]	[3246]	[3386]	[4092]			[14]	[ 630]	[1820]	[3005]	[4195]		
53,0	34 142	101 142	168 142	236 142	301 140	367 137	383 136	462 130			53,0	71 69	206 68	340 68	474 66		
Max. Continuous	[15]	[266]	[862]	[1452]	[2050]	[2630]	[3206]	[3347]	[4054]			Max. Continuous	[15]	[ 540]	[1735]	[2905]	[4130]
	56,8	30 152	97 152	164 152	232 152	297 150	362 148	378 147	458 140			56,8	61 74	196 74	328 73	467 72	
Max. Intermittent	[20]	[61]	[671]	[1269]	[1847]	[2410]	[2987]	[3119]			Max. Intermittent	[20]	[ 143]	[1350]	[2565]	[3705]	
	75,7	7 202	76 202	143 202	209 202	272 202	337 199	352 198			75,7	16 99	153 98	290 97	419 96		

[862] Torque [lb-in]  
97 Nm  
152 Speed RPM

# H Series (101-)

## Dimensions

(Refer to pages B-4-19 thru B-4-22 for shaft and port dimensions.)

## Standard Rotation Viewed from Shaft End

Port A Pressurized — CW

Port B Pressurized — CCW

## Note:

Mounting surface flatness requirement is  $\nabla$ , 13 mm [.005 inch] Max.

## Note:

End ported motor pressure is derated. Reference page B-2-2 for ratings.

## 2 Bolt Flange

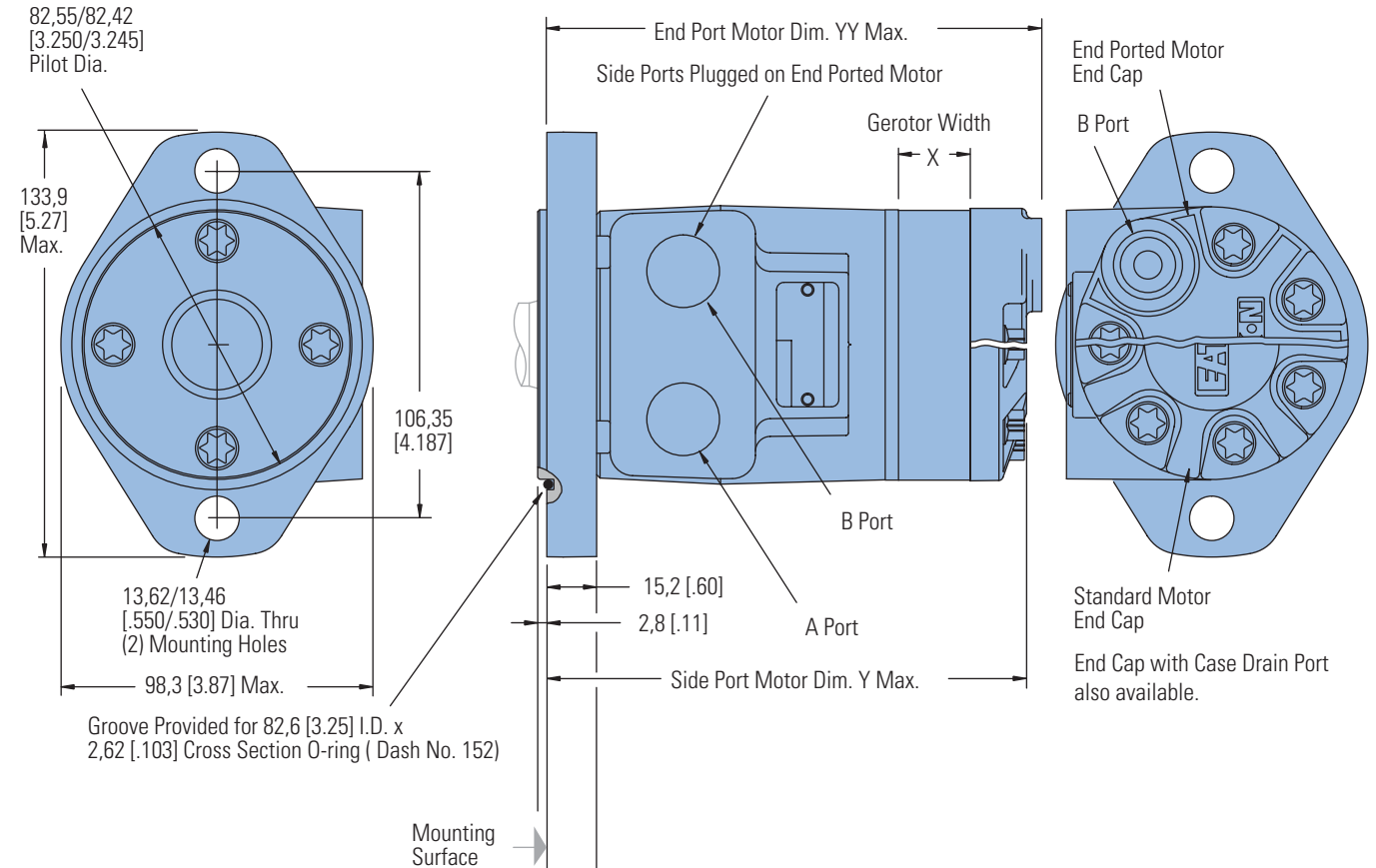

## 4 Bolt Flange

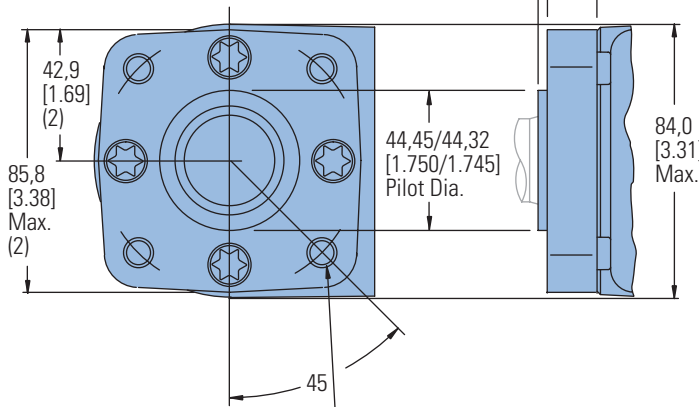

3/8-16 UNC (15,2 [.60] Max. Bolt Thread Engagement ) Mounting Holes (4) Equally Spaced on 82,6 [3.25] Dia. Bolt Circle or  
 M10 x 1,5 (15,2 [.60] Max. Bolt Thread Engagement ) Mounting Holes (4) Equally Spaced on 82,6 [3.25] Dia. Bolt Circle

## 2 AND 4 BOLT FLANGE

Displacement cm <sup>3</sup> /r [in <sup>3</sup> /r]	X mm [inch]	Y mm [inch]	YY mm [inch]
36 [ 2.2]	6,4 [ .25]	132,1 [5.20]	138,5 [5.45]
46 [ 2.8]	6,4 [ .25]	132,1 [5.20]	138,5 [5.45]
59 [ 3.6]	10,2 [ .40]	135,9 [5.35]	142,3 [5.60]
74 [ 4.5]	10,2 [ .40]	135,9 [5.35]	142,3 [5.60]
97 [ 5.9]	13,2 [ .52]	139,0 [5.47]	145,3 [5.72]
120 [ 7.3]	16,5 [ .65]	142,3 [5.60]	148,6 [5.85]
146 [ 8.9]	20,1 [ .79]	145,8 [5.74]	152,2 [5.99]
159 [ 9.7]	21,9 [ .86]	147,6 [5.81]	154,0 [6.06]
185 [11.3]	25,4 [1.00]	151,2 [5.95]	157,5 [6.20]
231 [14.1]	31,8 [1.25]	157,5 [6.20]	
293 [17.9]	40,4 [1.59]	166,2 [6.54]	
370 [22.6]	50,8 [2.00]	176,6 [6.95]	
739 [45.1]	101,6 [4.00]	227,4 [8.95]	

# H Series (101-)

## Product Numbers

Use digit prefix —101- plus four digit number from charts for complete product number—Example 101-1001. Orders will not be accepted without three digit prefix.

### 2 Bolt Flange

SHAFT	PORT SIZE	DISPL. cm <sup>3</sup> /r [in <sup>3</sup> /r] / PRODUCT NUMBER													
		36 [ 2.2]	46 [ 2.8]	59 [ 3.6]	74 [ 4.5]	97 [ 5.9]	120 [ 7.3]	146 [ 8.9]	159 [ 9.7]	185 [11.3]	231 [14.1]	293 [17.9]	370 [22.6]	740 [45.0]	
.1 in. Straight w/Woodruff key	7/8-14 O-Ring	101-1700	-1033	-1701	-1034	-1035	-1702	-1703	-1036	-1037	-1038	-1039	-1040	—	
	1/2 NPTF	101-1704	-1025	-1705	-1026	-1027	-1706	-1707	-1028	-1029	-1030	-1031	-1032	—	
	Manifold*	101-1708	-1041	-1709	-1042	-1043	-1710	-1711	-1044	-1045	-1046	-1047	-1048	—	
1 in. SAE 6B Splined	7/8-14 O-Ring	101-1721	-1081	-1722	-1082	-1083	-1723	-1724	-1084	-1085	-1086	-1087	-1088	—	
	1/2 NPTF	101-1725	-1073	-1726	-1074	-1075	-1727	-1728	-1076	-1077	-1078	-1079	-1080	—	
	Manifold*	101-1729	-1089	-1730	-1090	-1091	-1731	-1732	-1092	-1093	-1094	-1095	-1096	—	
1 in. Straight w/ .31 Dia. Crosshole	7/8-14 O-Ring	101-1796	-1797	-1798	-1799	-1800	-1801	-1802	-1803	—	—	—	—	—	
	1/2 NPTF	101-1804	-1805	-1806	-1807	-1808	-1870	-1809	-1810	—	—	—	—	—	
	Manifold*	101-1811	-1812	-1813	-1814	-1815	-1816	-1817	-1818	—	—	—	—	—	
1 in. Straight w/ .40 Dia. Crosshole	7/8-14 O-Ring	101-1819	-1323	-1820	-1324	-1325	-1821	-1822	-1326	—	—	—	—	—	
	1/2 NPTF	101-1823	-1319	-1824	-1320	-1825	-1826	-1827	-1828	—	—	—	—	—	
	Manifold*	101-1829	-1463	-1830	-1831	-1832	-1833	-1834	-1871	—	—	—	—	—	

101-1834

### 4 Bolt Flange

SHAFT	PORT SIZE	DISPL. cm <sup>3</sup> /r [in <sup>3</sup> /r] / PRODUCT NUMBER													
		36 [ 2.2]	46 [ 2.8]	59 [ 3.6]	74 [ 4.5]	97 [ 5.9]	120 [ 7.3]	146 [ 8.9]	159 [ 9.7]	185 [11.3]	231 [14.1]	293 [17.9]	370 [22.6]	740 [45.0]	
1 in. Straight w/ Woodruff key O-Ring	7/8-14 O-Ring	101-1749	-1009	-1750	-1010	-1011	-1751	-1752	-1012	-1013	-1014	-1015	-1016	—	
	1/2 NPTF	101-1753	-1001	-1754	-1002	-1003	-1755	-1756	-1004	-1005	-1006	-1007	-1008	—	
	Manifold*	101-1757	-1017	-1758	-1018	-1019	-1759	-1760	-1020	-1021	-1022	-1023	-1024	—	
1 in. SAE 6B Splined	7/8-14 O-Ring	101-1761	-1057	-1762	-1058	-1059	-1872	-1763	-1060	-1061	-1062	-1063	-1064	—	
	1/2 NPTF	101-1764	-1049	-1765	-1050	-1051	-1766	-1767	-1052	-1053	-1054	-1055	-1056	—	
	Manifold*	101-1768	-1065	-1769	-1066	-1067	-1770	-1771	-1068	-1069	-1070	-1071	-1072	—	
1 in. Straight w/ .31 Dia. Crosshole	7/8-14 O-Ring	101-1835	-1836	-1837	-1838	-1839	-1840	-1841	-1842	—	—	—	—	—	
	1/2 NPTF	101-1843	-1497	-1844	-1449	-1352	-1845	-1846	-1847	—	—	—	—	—	
	Manifold*	101-1848	-1466	-1849	-1459	-1850	-1851	-1852	-1853	—	—	—	—	—	
1 in. Straight w/ .40 Dia. Crosshole	7/8-14 O-Ring	101-1854	-1311	-1855	-1856	-1857	-1858	-1859	-1860	—	—	—	—	—	
	1/2 NPTF	101-1861	-1313	-1862	-1312	-1314	-1863	-1864	-1315	—	—	—	—	—	
	Manifold*	101-1865	-1305	-1866	-1306	-1307	-1867	-1868	-1869	—	—	—	—	—	

101-1868

### 4 Bolt Flange with Corrosion Protection

SHAFT	PORT SIZE	DISPL. cm <sup>3</sup> /r [in <sup>3</sup> /r] / PRODUCT NUMBER													
		36 [ 2.2]	46 [ 2.8]	59 [ 3.6]	74 [ 4.5]	97 [ 5.9]	120 [ 7.3]	146 [ 8.9]	159 [ 9.7]	185 [11.3]	231 [14.1]	293 [17.9]	370 [22.6]	740 [45.0]	
1 in. Straight w/ Woodruff Key	1/2 NPTF	101-2032	-2014	-2093	-2027	-2013	-2094	-2095	-2015	-2028	-2029	-2030	-2031	—	
	Manifold*		-2067							-2068	-2069				

\*Manifold product numbers shown are for motors with four 5/16-18 port face mounting threads. Manifold, manifold mounting O-Rings and bolts are NOT included.

For H Series Motors with a configuration Not Shown in the charts above: Use the model code system on page B-2-11 to specify the product in detail.



# H Series (101-)

## Model Code

The following 30-digit coding system has been developed to identify all of the configuration options for the H motor. Use this model code to specify a motor with the desired features. All 30-digits of the code must be present when ordering. You may want to photocopy the matrix below to ensure that each number is entered in the correct box.

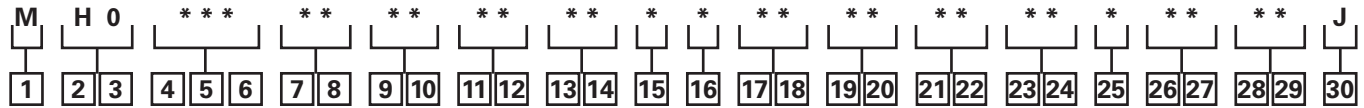

B-2

### 1 Product

M - Motor

### 2, 3 Series

H0 - H Motor

### 4, 5, 6 Displacement

cm<sup>3</sup>/r [in<sup>3</sup>/r]

- 022 - 36 [2.2]†
- 028 - 46 [2.8]
- 035 - 58 [3.5]†
- 045 - 74 [4.5]
- 059 - 96 [5.9]
- 073 - 120 [7.3]
- 089 - 146 [8.9]
- 097 - 159 [9.7]
- 113 - 185 [11.3]
- 141 - 231 [14.1]
- 179 - 294 [17.9]
- 226 - 370 [22.6]
- 451 - 739 [45.1]†

†The H Series motors with the displacement code "022", "035", or "451" must also specify free running gerotor. (Option "A" in position 15).

### 7, 8 Mounting Type

**A - 2 Bolt (Standard) 82.50 [3.248] Dia. x 3.05 [.120] Pilot, 13.59 [.535] Dia. Mounting Holes on 106.35 [4.187] Dia. B.C.**

**BA - 4 Bolt (Standard) 44.40 [1.748] Dia. x 3.05 [.120] Pilot, .375-16 UNC-2B Mounting Holes on 82.55 [3.250] Dia. B.C.**

CA - 2 Bolt (Standard) 82.50 [3.248] Dia. x 6.10 [.240] Pilot, 10.41 [.410] Dia. Mounting Holes on 106.35 [4.187] Dia. B.C. (SAE A)

DD - 2 Bolt (Standard) 101.60 [4.000] Dia. x 6.10 [.240] Pilot, 14.35 [.565] Dia. Mounting Holes on 146.05 [5.750] Dia. B.C. (SAE B)

**FA - 4 Bolt (Standard) 44.40 [1.748] Dia. x 3.05 [.120] Pilot, M10 x 1.5-6H Mounting Holes on 82.55 [3.250] Dia. B.C.**

MA - 2 Bolt (Standard) 82.50 [3.248] Dia. x 8.13 [.320] Pilot, 13.59 [.535] Dia. Mounting Holes on 106.35 [4.187] Dia. B.C., w/o O-ring Groove

### 9, 10 Output Shaft

**01 - 25.4 [1.00] Dia. Straight, Woodruff Key, .250-20 UNC-2B Hole in Shaft End**

**02 - 25.4 [1.00] Dia. SAE 6B Spline, .250-20 UNC-2B Hole in Shaft End**

07 - 25.4 [1.00] Dia. Straight, 8.03 [.316] Dia. Cross Hole 11.2 [.44] from End, 5.6 [.22] Extra Length

**08 - 25.4 [1.00] Dia. Straight, 10.31 [.406] Dia. Cross Hole 15.7 [.62] from End, .250-20 UNC-2B Hole in Shaft End**

**16 - 22.22 [.875] Dia. SAE 13 Tooth Spline (SAE B)**

17 - 22.22 [.875] Dia. Straight, 6.4 [.25] x 19.0 [.75] Square Key (SAE B)

18 - 25.4 [1.00] Dia. Tapered, Woodruff Key and Nut, 34.92 [1.375] Taper Length

**24 - 25.00 [.984] Dia. Straight, 8.00 [.315] KEY, M8 x 1.25-6H Hole in Shaft End**

39 - 25.00 [.984] Dia. Straight (k6), 8.00 [.315] Key, M8 x 1.25-6H Hole in Shaft End

### 11, 12 Ports

**AA - .875-14 UNF-2B SAE O-Ring Ports**

**AB - .500-14 NPTF Dry Seal Pipe Thread Ports**

**AC - Manifold Ports (.3125-18 UNC-2B Mounting Holes)**

AD - Manifold Ports (M8 x 1.25-6H Mounting Holes)

**AF - G 1/2 BSP Straight Thread Ports**

EB†† - End Ports: .750-16 UNF-2B SAE O-Ring Ports

EC†† - End Ports: G 1/2 BSP Straight Thread Ports

†† Note: End ported motor pressure is derated. Reference page B-2-2 for ratings.

### 13, 14 Case Flow Options

00 - None

**01 - .4375-20 UNF-2B SAE O-Ring Port (End Cap)**

**02 - G 1/4 BSP Straight THD Port (End Cap)**

**03 - Manifold case drain**

04 - .4375-20 UNF-2B SAE O-ring port (side of housing)

05 - .3125-24 UNF-2B SAE O-ring port (mounting flange)

**11 - Internal Check Valves**

### 15 Gerotor Options

0 - None

A - Free Running

### 16 Shaft Options

0 - None

N - Electroless Nickel Plated

### 17, 18 Seal Options

**00 - Standard Seals**

02 - Seal Guard

03 - Viton Seals

**04 - Viton Shaft Seal**

**07 - High Pressure Shaft Seal**

11 - High pressure shaft seal, slinger seal

**19 - Extreme duty seal guard**

### 19, 20 Speed Sensor Options

00 - None

AA - 12mm digital speed pickup (15 pulse) without lead wire

AB - Magnetic Speed Pickup (60 Pulse by Quadrature), No Lead Wire with M12 Connector (A=Power, B=Common, C=Signal)

### 21, 22 Valve Options

00 - None

\* - Contact your Eaton Sales Representative for available options.

### 23, 24 Special Features (Hardware)

00 - None

AB - Low Speed Valving

SS - Stainless Steel Flange Bolts

### 25 Special Assembly Instructions

0 - None

1 - Reverse Rotation

2 - Flange Rotated 90°

### 26, 27 Paint/ Special Packaging

00 - No Paint

**AA - Low Gloss Black Primer**

AD - Environmental Coated Gloss White

AF - Environmental Coated Black

### 28, 29 Eaton Assigned Code when Applicable

00 - Assigned Code

### 30 Eaton Assigned Design Code

J - Nine (9)

Feature in **bold** are preferred and allow for shorter lead time.

# Notes

# S Series (103-)

Highlights

**New, improved design!**

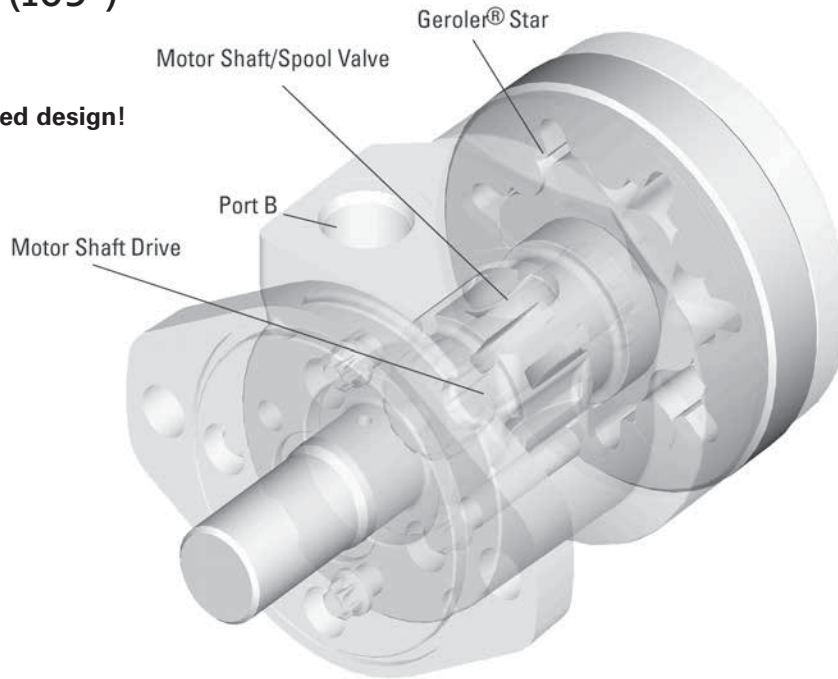

## Description

The new improved Char-Lynn S Series motors with optimized Geroler geometry offers enhanced performance with reduced drive-running angle while retaining the overall package size of the original S series. Design improvements include upgraded steel end cap, O-Ring section seals, and optimized Geroler set. The Geroler set has precision-machined rollers in the outer ring which provide support with rolling contact between the star and ring. This improves mechanical efficiency, especially at start-up and at low speed conditions. Improvements incorporated into the latest S Series motor provide reliable leak-free performance and smooth operation at start-up conditions.

## Specifications

Geroler Element	10 Displacements
Flow l/min [GPM]	55 [15] Continuous*** 75 [20] Intermittent**
Speed	Up to 963 RPM
Pressure bar [PSI]	135 [2000] Cont.*** 170 [2500] Inter.**
Torque Nm [lb-in]	528 [4672] Cont.*** 587 [5190] Inter.**

\*\*\* Continuous— (Cont.) Continuous rating, motor may be run continuously at these ratings.

\*\* Intermittent— (Inter.) Intermittent operation, 10% of every minute.

## Features:

- Constant clearance Geroler, design
- Three moving components (gerotor, drive, shaft)
- Optimized drive running angle
- Three-zone pressure design (inlet, return and case)
- Variety of displacements, shafts and mounts
- Special options to meet customer needs!

## Benefits:

- High efficiency
- Smooth low speed operation!
- Extended motor life
- Design flexibility
- Ability to optimize designs for your application needs
- Extended leak-free performance

## Applications:

- Agricultural augers, harvesters, seeders
- Car wash brushes
- Food processing
- Railroad maintenance equipment
- Machine tools
- Conveyors
- Industrial sweepers and floor polishers
- Saw mill works
- Turf equipment
- Concrete and asphalt equipment
- Skid steer attachments
- Many more

B-3



Conveyor



Casting



Amusement ride



Combine

# S Series (103-)

## Specifications

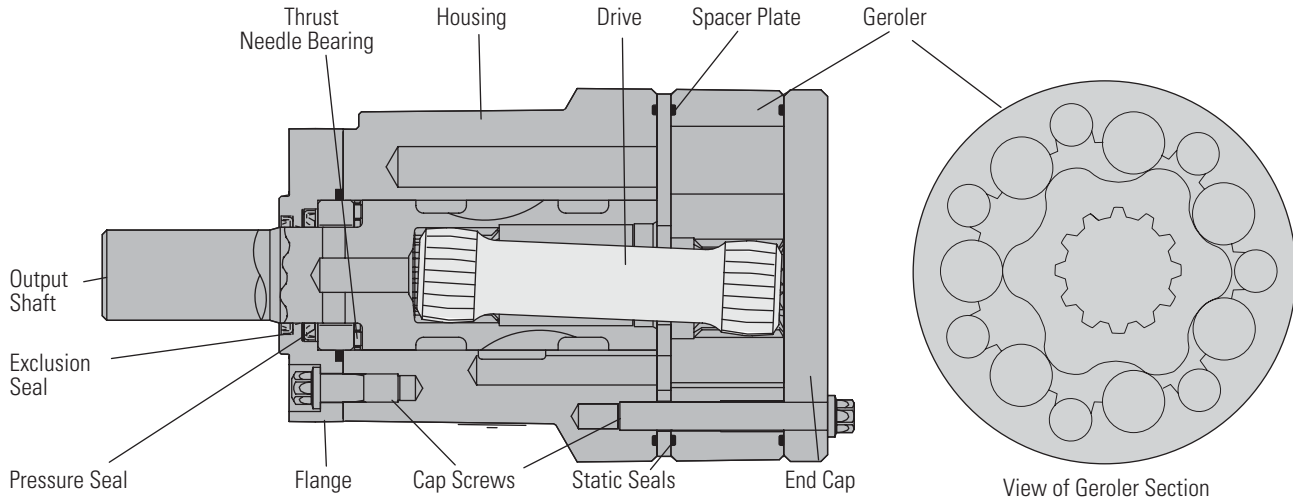

### SPECIFICATION DATA – S MOTORS

Displ. cm <sup>3</sup> /r [in <sup>3</sup> /r]		59 [ 3.6]	75 [ 4.6]	97 [ 5.7]	120 [ 7.3]	144 [ 8.8]	166 [ 10.1]	187 [11.4]	225 [13.7]	298 [18.2]	372 [22.7]
Max. Speed (RPM) @ Continuous Flow		963	792	607	472	394	343	304	253	190	153
Flow LPM [GPM]	Continuous	57 [15]	57 [15]	57 [15]	57 [15]	57 [15]	57 [15]	57 [15]	57 [15]	57 [15]	57 [15]
	Intermittent	68 [18]	76 [20]	76 [20]	76 [20]	76 [20]	76 [20]	76 [20]	76 [20]	76 [20]	76 [20]
Torque Nm [lb-in]	Continuous	115 [1021]	150 [1325]	183 [1623]	237 [2010]	265 [2347]	301 [2662]	333 [2950]	372 [3290]	491 [4345]	528 [4672]
	Intermittent	144 [1271]	186 [1649]	225 [1992]	292 [2582]	324 [2870]	360 [3191]	399 [3533]	434 [3843]	505 [4467]	587 [5200]
Min. Starting Torque Nm[lb-in]	@ Cont. Pressure	90 [ 800]	113 [1000]	148 [1310]	184 [1630]	212 [2050]	232 [2330]	263 [2670]	302 [2990]	338 [3270]	369 [3270]
	@ Int. Pressure	116 [1030]	146 [1290]	190 [1680]	236 [2090]	271 [2400]	289 [2560]	329 [2910]	374 [3310]	417 [3690]	438 [3880]
Pressure Δ Bar [Δ PSI]	Continuous	138 [2000]	138 [2000]	138 [2000]	138 [2000]	131 [1900]	131 [1900]	128 [1850]	117 [1700]	103 [1500]	90 [1300]
	Intermittent	172 [2500]	172 [2500]	172 [2500]	172 [2500]	162 [2350]	159 [2300]	155 [2250]	141 [2050]	124 [1800]	103 [1500]

**A simultaneous maximum torque and maximum speed NOT recommended.**

#### Note:

To assure best motor life, run motor for approximately one hour at 30% of rated pressure before application to full load. Be sure motor is filled with fluid prior to any load applications.

#### Maximum Inlet Pressure:

172 Bar [2500 PSI] without regard to Δ Bar [Δ PSI] and/or back pressure ratings or combination thereof.

6B Splined or Tapered shafts are recommended whenever operating above 282 NM [2500 lb-in] of torque, especially for those applications subject to frequent reversals.

#### Δ Pressure:

The true Δ bar [Δ PSI] between inlet port and outlet port

#### Continuous Rating:

Motor may be run continuously at these ratings

#### Intermittent Operation:

10% of every minute

#### Recommended Fluids:

Premium quality, anti-wear type hydraulic oil with a viscosity of not less than 70 SUS at operating temperature.

#### Recommended System Operating Temp.:

-34°C to 82°C [-30°F to 180°F]

#### Recommended Filtration:

per ISO Cleanliness Code 4406, level 20/18/13

# S Series (103-)

## Performance Data

Motors run with high efficiency in all areas designated with a number for torque and speed, however for best motor life select a motor to run with a torque and speed range printed in the light shaded area.

Performance data is typical at 120 SUS. Actual data may vary slightly from unit to unit in production

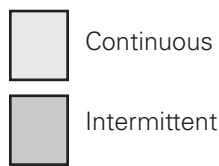

### S Motor 59 cm<sup>3</sup>/r [3.6 in<sup>3</sup>/r]

Δ Pressure Bar [PSI]

	[200] 14	[400] 28	[600] 41	[800] 55	[1000] 69	[1200] 83	[1400] 97	[1600] 110	[1800] 124	[2000] 138	[2500] 172
[2]	86	190	292	390	484	578	662	729	764	803	
<b>7,6</b>	10 126	22 121	33 115	44 107	55 97	65 85	75 75	82 63	86 45	91 24	
[4]	79	185	289	395	498	600	702	804	903	998	1156
<b>15,1</b>	9 256	21 250	33 243	45 235	56 224	68 212	79 199	91 183	102 166	113 147	131 89
[6]	71	177	280	387	495	602	704	808	909	1011	1257
<b>22,7</b>	8 383	20 377	32 369	44 360	56 349	68 336	80 320	91 302	103 284	114 266	142 207
[8]	62	166	274	379	488	594	699	806	907	1007	1264
<b>30,3</b>	7 514	19 508	31 500	43 490	55 477	67 464	79 448	91 430	102 409	114 390	143 333
[10]	52	155	264	369	475	583	686	793	897	1000	1257
<b>37,9</b>	6 642	17 635	30 628	42 617	54 605	66 591	78 575	90 557	101 538	113 517	142 461
[12]	38	141	248	354	462	568	674	777	884	987	1244
<b>45,4</b>	4 772	16 764	28 757	40 747	52 736	64 722	76 706	88 687	100 670	111 648	141 592
[14]	21	125	231	337	445	551	658	763	868	972	1233
<b>53,0</b>	2 900	14 893	26 885	38 876	50 866	62 852	74 836	86 819	98 798	110 778	139 721
[15]	8	116	223	328	434	543	648	756	862	965	1225
<b>56,8</b>	1 482	13 958	25 949	37 940	49 929	61 915	73 900	85 882	97 863	109 842	138 784
[18]		86	191	296	403	511	617	726	831	935	1195
<b>68,1</b>		10 1151	22 1139	33 1128	46 1117	58 1105	70 1090	82 1074	94 1054	106 1033	135 977

### S Motor 75 cm<sup>3</sup>/r [4.6 in<sup>3</sup>/r]

Δ Pressure Bar [PSI]

	[200] 14	[400] 28	[600] 41	[800] 55	[1000] 69	[1200] 83	[1400] 97	[1600] 110	[1800] 124	[2000] 138	[2500] 172
[2]	91	218	343	467	590	708	815	900	981	1086	
<b>7,6</b>	10 93	25 89	39 81	53 75	67 66	80 59	92 43	102 21	111 23	123 16	
[4]	87	217	352	484	616	748	874	1001	1123	1236	1472
<b>15,1</b>	10 193	25 188	40 181	55 173	70 163	85 150	99 139	113 125	127 107	140 89	166 37
[6]	82	219	355	492	627	763	898	1027	1155	1284	1590
<b>22,7</b>	9 292	25 286	40 277	56 269	71 258	86 244	101 228	116 214	131 202	145 186	180 140
[8]	69	202	341	481	619	761	896	1032	1165	1296	1618
<b>30,3</b>	8 390	23 384	38 375	54 364	70 355	86 342	101 326	117 309	132 295	146 276	183 230
[10]	56	193	330	471	610	751	887	1025	1162	1297	1628
<b>37,9</b>	6 489	22 484	37 476	53 467	69 457	85 444	100 431	116 416	131 399	147 381	184 336
[12]	39	175	315	453	595	736	873	1011	1148	1284	1617
<b>45,4</b>	4 587	20 582	36 573	51 564	67 552	83 540	99 526	114 510	130 494	145 476	183 427
[14]	12	153	290	431	571	716	856	993	1129	1265	1605
<b>53,0</b>	1 343	17 680	33 673	49 665	65 654	81 641	97 628	112 613	128 594	143 578	181 533
[15]	9	143	281	424	567	708	846	985	1121	1259	1599
<b>56,8</b>	1 491	16 729	32 723	48 714	64 704	80 690	96 675	111 661	127 644	142 628	181 580
[20]		82	220	362	505	645	784	922	1061	1200	1545
<b>75,7</b>		9 970	25 963	41 957	57 948	73 935	89 921	104 906	120 888	136 871	175 825



[143]  
16 } Torque [lb-in]  
729 } Nm  
Speed RPM

# S Series (103-)

## Performance Data

Motors run with high efficiency in all areas designated with a number for torque and speed, however for best motor life select a motor to run with a torque and speed range printed in the light shaded area.

Performance data is typical at 120 SUS. Actual data may vary slightly from unit to unit in production

 Continuous  
 Intermittent

### S Motor 93 cm<sup>3</sup>/r [5.7 in<sup>3</sup>/r]

Δ Pressure Bar [PSI]

	[200]	[400]	[600]	[800]	[1000]	[1200]	[1400]	[1600]	[1800]	[2000]	[2500]
	14	28	41	55	69	83	97	110	124	138	172
[2]	146	308	466	620	771	913	1031	1086	1176	1281	
	16	35	53	70	87	103	116	123	133	145	
<b>7,6</b>	<b>76</b>	<b>72</b>	<b>64</b>	<b>55</b>	<b>48</b>	<b>34</b>	<b>22</b>	<b>7</b>	<b>4</b>	<b>1</b>	
[4]	136	301	466	633	797	959	1116	1275	1430	1570	1798
	15	34	53	72	90	108	126	144	162	177	203
<b>15,1</b>	<b>158</b>	<b>153</b>	<b>146</b>	<b>138</b>	<b>126</b>	<b>115</b>	<b>103</b>	<b>90</b>	<b>77</b>	<b>59</b>	<b>17</b>
[6]	113	278	446	616	786	952	1116	1280	1444	1603	1971
	13	31	50	70	89	108	126	145	163	181	223
<b>22,7</b>	<b>238</b>	<b>232</b>	<b>225</b>	<b>215</b>	<b>206</b>	<b>191</b>	<b>175</b>	<b>161</b>	<b>145</b>	<b>129</b>	<b>87</b>
[8]	98	262	431	604	777	947	1112	1279	1446	1610	2006
	11	30	49	68	88	107	126	144	163	182	227
<b>30,3</b>	<b>319</b>	<b>313</b>	<b>306</b>	<b>296</b>	<b>284</b>	<b>270</b>	<b>255</b>	<b>240</b>	<b>224</b>	<b>208</b>	<b>165</b>
[10]	81	246	415	590	763	935	1100	1271	1439	1604	2012
	9	28	47	67	86	106	124	144	163	181	227
<b>37,9</b>	<b>400</b>	<b>394</b>	<b>388</b>	<b>378</b>	<b>366</b>	<b>353</b>	<b>340</b>	<b>324</b>	<b>306</b>	<b>288</b>	<b>244</b>
[12]	65	232	401	574	746	916	1081	1255	1425	1591	2001
	7	26	45	65	84	103	122	142	161	180	226
<b>45,4</b>	<b>481</b>	<b>476</b>	<b>469</b>	<b>460</b>	<b>448</b>	<b>435</b>	<b>423</b>	<b>408</b>	<b>394</b>	<b>374</b>	<b>326</b>
[14]	42	207	376	552	721	893	1064	1235	1405	1570	1983
	5	23	43	62	81	101	120	140	159	177	224
<b>53,0</b>	<b>561</b>	<b>557</b>	<b>549</b>	<b>541</b>	<b>531</b>	<b>519</b>	<b>504</b>	<b>489</b>	<b>470</b>	<b>455</b>	<b>412</b>
[15]	31	196	364	538	708	881	1052	1223	1391	1560	1974
	4	22	41	61	80	100	119	138	157	176	223
<b>56,8</b>	<b>602</b>	<b>597</b>	<b>591</b>	<b>582</b>	<b>571</b>	<b>559</b>	<b>546</b>	<b>530</b>	<b>514</b>	<b>498</b>	<b>453</b>
[20]		119	290	461	633	807	976	1145	1315	1485	1904
		13	33	52	72	91	110	129	149	168	215
<b>75,7</b>		<b>799</b>	<b>792</b>	<b>785</b>	<b>775</b>	<b>762</b>	<b>748</b>	<b>734</b>	<b>717</b>	<b>702</b>	<b>660</b>

### S Motor 120 cm<sup>3</sup>/r [7.3 in<sup>3</sup>/r]

Δ Pressure Bar [PSI]

	[200]	[400]	[600]	[800]	[1000]	[1200]	[1400]	[1600]	[1800]	[2000]	[2500]
	14	28	41	55	69	83	97	110	124	138	172
[2]	191	403	605	801	978	1146	1288	1440	1552	1679	
	22	46	68	91	110	129	146	163	175	190	
<b>7,6</b>	<b>60</b>	<b>56</b>	<b>50</b>	<b>43</b>	<b>36</b>	<b>29</b>	<b>19</b>	<b>15</b>	<b>8</b>	<b>6</b>	
[4]	188	403	617	829	1031	1236	1438	1632	1816	1990	1914
	21	46	70	94	117	140	162	184	205	225	216
<b>15,1</b>	<b>122</b>	<b>118</b>	<b>112</b>	<b>106</b>	<b>98</b>	<b>87</b>	<b>78</b>	<b>67</b>	<b>56</b>	<b>49</b>	<b>16</b>
[6]	172	391	607	821	1030	1241	1449	1654	1858	2056	2522
	19	44	69	93	116	140	164	187	210	232	285
<b>22,7</b>	<b>186</b>	<b>180</b>	<b>175</b>	<b>167</b>	<b>159</b>	<b>149</b>	<b>137</b>	<b>126</b>	<b>114</b>	<b>103</b>	<b>73</b>
[8]	156	375	593	807	1015	1229	1439	1648	1855	2059	2557
	18	42	67	91	115	139	163	186	210	233	289
<b>30,3</b>	<b>249</b>	<b>244</b>	<b>237</b>	<b>229</b>	<b>220</b>	<b>210</b>	<b>199</b>	<b>185</b>	<b>174</b>	<b>162</b>	<b>128</b>
[10]	130	349	567	785	995	1210	1420	1630	1838	2045	2559
	15	39	64	89	112	137	160	184	208	231	289
<b>37,9</b>	<b>311</b>	<b>307</b>	<b>301</b>	<b>293</b>	<b>286</b>	<b>275</b>	<b>264</b>	<b>252</b>	<b>239</b>	<b>227</b>	<b>193</b>
[12]	103	320	539	756	965	1175	1383	1593	1799	2003	2500
	12	36	61	85	109	133	156	180	203	226	282
<b>45,4</b>	<b>374</b>	<b>369</b>	<b>363</b>	<b>355</b>	<b>346</b>	<b>336</b>	<b>327</b>	<b>314</b>	<b>303</b>	<b>288</b>	<b>253</b>
[14]	70	285	502	715	923	1131	1335	1540	1745	1948	2452
	8	32	57	81	104	128	151	174	197	220	277
<b>53,0</b>	<b>437</b>	<b>433</b>	<b>427</b>	<b>419</b>	<b>411</b>	<b>402</b>	<b>391</b>	<b>379</b>	<b>369</b>	<b>355</b>	<b>322</b>
[15]	54	267	485	705	913	1122	1329	1540	1746	1947	2441
	6	30	55	80	103	127	150	174	197	220	276
<b>56,8</b>	<b>469</b>	<b>465</b>	<b>459</b>	<b>452</b>	<b>444</b>	<b>433</b>	<b>423</b>	<b>411</b>	<b>400</b>	<b>386</b>	<b>349</b>
[20]		159	377	600	815	1026	1232	1444	1651	1859	2383
		18	43	68	92	116	139	163	186	210	269
<b>75,7</b>		<b>621</b>	<b>618</b>	<b>612</b>	<b>603</b>	<b>594</b>	<b>583</b>	<b>571</b>	<b>560</b>	<b>549</b>	<b>515</b>

[267] } Torque [lb-in]  
 30 } Nm  
 465 } Speed RPM

# S Series (103-)

## Performance Data

Motors run with high efficiency in all areas designated with a number for torque and speed, however for best motor life select a motor to run with a torque and speed range printed in the light shaded area.

Performance data is typical at 120 SUS. Actual data may vary slightly from unit to unit in production

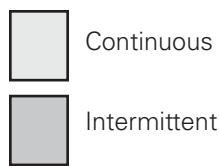

### S Motor 144 cm<sup>3</sup>/r [8.8 in<sup>3</sup>/r]

Δ Pressure Bar [PSI]

	[200]	[400]	[600]	[800]	[1000]	[1200]	[1400]	[1600]	[1800]	[1900]	[2350]
	<b>14</b>	<b>28</b>	<b>41</b>	<b>55</b>	<b>69</b>	<b>83</b>	<b>97</b>	<b>110</b>	<b>124</b>	<b>138</b>	<b>172</b>
[2]	222	480	729	967	1190	1402	1591	1786	2031	2107	
<b>7,6</b>	25	54	82	109	134	158	180	202	229	238	
	<b>49</b>	<b>45</b>	<b>40</b>	<b>34</b>	<b>29</b>	<b>21</b>	<b>17</b>	<b>13</b>	<b>14</b>	<b>14</b>	
[4]	217	475	728	987	1237	1488	1727	1957	2181	2292	2310
<b>15,1</b>	24	54	82	112	140	168	195	221	246	259	261
	<b>101</b>	<b>97</b>	<b>91</b>	<b>84</b>	<b>77</b>	<b>69</b>	<b>61</b>	<b>52</b>	<b>45</b>	<b>42</b>	<b>22</b>
[6]	193	453	715	976	1234	1494	1746	1995	2239	2358	2867
<b>22,7</b>	22	51	81	110	139	169	197	225	253	266	324
	<b>153</b>	<b>149</b>	<b>143</b>	<b>136</b>	<b>128</b>	<b>119</b>	<b>110</b>	<b>101</b>	<b>91</b>	<b>86</b>	<b>66</b>
[8]	173	434	699	961	1218	1479	1735	1984	2235	2358	2894
<b>30,3</b>	20	49	79	109	138	167	196	224	252	266	327
	<b>205</b>	<b>202</b>	<b>195</b>	<b>187</b>	<b>179</b>	<b>170</b>	<b>160</b>	<b>150</b>	<b>139</b>	<b>134</b>	<b>109</b>
[10]	144	407	673	940	1197	1459	1715	1967	2218	2344	2890
<b>37,9</b>	16	46	76	106	135	165	194	222	251	265	327
	<b>259</b>	<b>254</b>	<b>247</b>	<b>240</b>	<b>231</b>	<b>221</b>	<b>211</b>	<b>202</b>	<b>191</b>	<b>185</b>	<b>158</b>
[12]	118	380	644	907	1167	1429	1685	1941	2194	2319	2878
<b>45,4</b>	13	43	73	102	132	161	190	219	248	262	325
	<b>312</b>	<b>307</b>	<b>301</b>	<b>294</b>	<b>286</b>	<b>277</b>	<b>267</b>	<b>257</b>	<b>246</b>	<b>241</b>	<b>217</b>
[14]	87	346	610	871	1131	1395	1651	1907	2163	2289	2851
<b>53,0</b>	10	39	69	98	128	158	187	215	244	259	322
	<b>363</b>	<b>359</b>	<b>354</b>	<b>346</b>	<b>339</b>	<b>330</b>	<b>319</b>	<b>309</b>	<b>299</b>	<b>293</b>	<b>266</b>
[15]	69	327	592	853	1113	1376	1633	1890	2146	2271	2835
<b>56,8</b>	8	37	67	96	126	156	185	214	242	257	320
	<b>389</b>	<b>386</b>	<b>380</b>	<b>372</b>	<b>364</b>	<b>355</b>	<b>344</b>	<b>336</b>	<b>323</b>	<b>317</b>	<b>289</b>
[20]		200	460	726	987	1251	1512	1770	2025	2153	2724
<b>75,7</b>		23	52	82	112	141	171	200	229	243	308
		<b>516</b>	<b>513</b>	<b>507</b>	<b>499</b>	<b>491</b>	<b>480</b>	<b>470</b>	<b>459</b>	<b>454</b>	<b>427</b>

### S Motor 166 cm<sup>3</sup>/r [10.1 in<sup>3</sup>/r]

Δ Pressure Bar [PSI]

	[200]	[400]	[600]	[800]	[1000]	[1200]	[1400]	[1600]	[1800]	[1900]	[2300]
	<b>14</b>	<b>28</b>	<b>41</b>	<b>55</b>	<b>69</b>	<b>83</b>	<b>97</b>	<b>110</b>	<b>124</b>	<b>138</b>	<b>172</b>
[2]	267	563	841	1105	1364	1622	1852	2081	2288		
<b>7,6</b>	30	64	95	125	154	183	209	235	259		
	<b>43</b>	<b>39</b>	<b>35</b>	<b>30</b>	<b>27</b>	<b>21</b>	<b>16</b>	<b>13</b>	<b>13</b>		
[4]	247	544	838	1129	1418	1707	1988	2255	2514	2641	3116
<b>15,1</b>	28	61	95	128	160	193	225	255	284	298	352
	<b>89</b>	<b>85</b>	<b>80</b>	<b>74</b>	<b>68</b>	<b>60</b>	<b>53</b>	<b>47</b>	<b>41</b>	<b>38</b>	<b>28</b>
[6]	217	517	813	1108	1401	1700	1994	2281	2559	2692	3214
<b>22,7</b>	25	58	92	125	158	192	225	258	289	304	363
	<b>134</b>	<b>131</b>	<b>125</b>	<b>120</b>	<b>113</b>	<b>105</b>	<b>96</b>	<b>88</b>	<b>79</b>	<b>75</b>	<b>58</b>
[8]	195	494	794	1089	1387	1687	1983	2269	2552	2691	3239
<b>30,3</b>	22	56	90	123	157	191	224	256	288	304	366
	<b>180</b>	<b>176</b>	<b>171</b>	<b>164</b>	<b>156</b>	<b>147</b>	<b>138</b>	<b>128</b>	<b>118</b>	<b>114</b>	<b>96</b>
[10]	176	477	776	1072	1371	1668	1960	2249	2537	2676	3228
<b>37,9</b>	20	54	88	121	155	188	221	254	287	302	365
	<b>227</b>	<b>222</b>	<b>217</b>	<b>210</b>	<b>203</b>	<b>194</b>	<b>185</b>	<b>175</b>	<b>165</b>	<b>160</b>	<b>136</b>
[12]	136	436	737	1037	1335	1636	1928	2217	2509	2651	3210
<b>45,4</b>	15	49	83	117	151	185	218	251	284	300	363
	<b>272</b>	<b>269</b>	<b>264</b>	<b>258</b>	<b>249</b>	<b>241</b>	<b>233</b>	<b>223</b>	<b>214</b>	<b>208</b>	<b>186</b>
[14]	93	394	696	995	1296	1599	1890	2185	2475	2617	3178
<b>53,0</b>	11	44	79	112	146	181	214	247	280	296	359
	<b>318</b>	<b>315</b>	<b>310</b>	<b>303</b>	<b>296</b>	<b>287</b>	<b>279</b>	<b>269</b>	<b>259</b>	<b>254</b>	<b>230</b>
[15]	73	371	672	973	1272	1575	1867	2159	2453	2596	3158
<b>56,8</b>	8	42	76	110	144	178	211	244	277	293	357
	<b>341</b>	<b>338</b>	<b>333</b>	<b>326</b>	<b>319</b>	<b>309</b>	<b>300</b>	<b>290</b>	<b>280</b>	<b>274</b>	<b>253</b>
[20]		227	527	829	1128	1430	1724	2020	2313	2457	3030
<b>75,7</b>		26	60	94	127	162	195	228	261	278	342
		<b>452</b>	<b>449</b>	<b>443</b>	<b>435</b>	<b>426</b>	<b>417</b>	<b>407</b>	<b>396</b>	<b>390</b>	<b>366</b>



[371] } Torque [lb-in]  
42 } Nm  
338 } Speed RPM

# S Series (103-)

## Performance Data

Motors run with high efficiency in all areas designated with a number for torque and speed, however for best motor life select a motor to run with a torque and speed range printed in the light shaded area.

Performance data is typical at 120 SUS. Actual data may vary slightly from unit to unit in production

 Continuous  
 Intermittent

### S Motor 187 cm<sup>3</sup>/r [11.4 in<sup>3</sup>/r]

Δ Pressure Bar [PSI]

	[200]	[400]	[600]	[800]	[1000]	[1200]	[1400]	[1600]	[1800]	[1850]	[2250]
	14	28	41	55	69	83	97	110	124	138	172
[2]	298	627	944	1244	1532	1805	2030	2250	2478		
<b>7,6</b>	34	71	107	141	173	204	229	254	280		
[4]	298	640	969	1291	1607	1919	2219	2511	2799	2869	3411
<b>15,1</b>	34	72	109	146	182	217	251	284	316	324	385
[6]	279	621	953	1283	1608	1930	2243	2551	2850	2922	3502
<b>22,7</b>	32	70	108	145	182	218	253	288	322	330	396
[8]	252	593	928	1257	1579	1905	2224	2542	2855	2932	3539
<b>30,3</b>	28	67	105	142	178	215	251	287	323	331	400
[10]	211	555	888	1217	1546	1872	2193	2516	2831	2909	3518
<b>37,9</b>	24	63	100	138	175	211	248	284	320	329	397
[12]	162	502	835	1164	1490	1818	2139	2463	2780	2857	3476
<b>45,4</b>	18	57	94	131	168	205	242	278	314	323	393
[14]	118	452	786	1117	1443	1772	2095	2417	2736	2814	3438
<b>53,0</b>	13	51	89	126	163	200	237	273	309	318	388
[15]	91	425	759	1089	1418	1747	2068	2389	2708	2786	3410
<b>56,8</b>	10	48	86	123	160	197	234	270	306	315	385
[20]		259	590	925	1255	1585	1907	2229	2552	2633	3265
<b>75,7</b>		29	67	105	142	179	216	252	288	297	369
		<b>403</b>	<b>400</b>	<b>394</b>	<b>387</b>	<b>379</b>	<b>370</b>	<b>359</b>	<b>347</b>	<b>344</b>	<b>319</b>

### S Motor 225 cm<sup>3</sup>/r [13.7 in<sup>3</sup>/r]

Δ Pressure Bar [PSI]

	[200]	[400]	[600]	[800]	[1000]	[1200]	[1400]	[1600]	[1700]	[2050]
	14	28	41	55	69	83	97	110	124	138
[2]	358	765	1139	1498	1842	2163	2474	2738	2894	
<b>7,6</b>	40	86	129	169	208	244	280	309	327	
[4]	367	774	1177	1577	1956	2325	2680	3022	3191	3753
<b>15,1</b>	41	87	133	178	221	263	303	341	361	424
[6]	348	758	1161	1567	1960	2344	2716	3083	3264	3863
<b>22,7</b>	39	86	131	177	221	265	307	348	369	437
[8]	313	721	1124	1529	1921	2312	2696	3073	3265	3894
<b>30,3</b>	35	81	127	173	217	261	305	347	369	440
[10]	262	669	1069	1473	1859	2247	2627	2997	3184	3810
<b>37,9</b>	30	76	121	166	210	254	297	339	360	430
[12]	203	609	1006	1400	1782	2160	2531	2912	3098	3721
<b>45,4</b>	23	69	114	158	201	244	286	329	350	420
[14]	143	544	938	1324	1700	2079	2452	2824	3008	3639
<b>53,0</b>	16	62	106	150	192	235	277	319	340	411
[15]	106	504	897	1281	1653	2027	2393	2761	2944	3576
<b>56,8</b>	12	57	101	145	187	229	270	312	333	404
[20]		303	697	1091	1477	1854	2214	2581	2765	3399
<b>75,7</b>		34	79	123	167	210	250	292	312	384
		<b>336</b>	<b>334</b>	<b>330</b>	<b>325</b>	<b>318</b>	<b>312</b>	<b>304</b>	<b>298</b>	<b>282</b>

{ [504]  
57  
251 } Torque [lb-in]  
Nm  
Speed RPM



# S Series (103-)

## Performance Data

Motors run with high efficiency in all areas designated with a number for torque and speed, however for best motor life select a motor to run with a torque and speed range printed in the light shaded area.

Performance data is typical at 120 SUS. Actual data may vary slightly from unit to unit in production

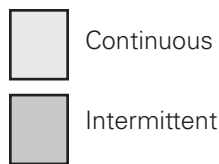

### S Motor 298 cm<sup>3</sup>/r [18.2 in<sup>3</sup>/r]

Δ Pressure Bar [PSI]

	[200]	[400]	[600]	[800]	[1000]	[1200]	[1400]	[1500]	[1800]
	<b>14</b>	<b>28</b>	<b>41</b>	<b>55</b>	<b>69</b>	<b>83</b>	<b>97</b>	<b>110</b>	<b>124</b>
[2]	487	1009	1509	1991	2460	2931	3360	3577	4113
<b>7,6</b>	55	114	170	225	278	331	380	404	465
	<b>24</b>	<b>22</b>	<b>20</b>	<b>18</b>	<b>17</b>	<b>14</b>	<b>11</b>	<b>10</b>	<b>8</b>
[4]	498	1043	1576	2093	2597	3087	3567	3798	4500
<b>15,1</b>	56	118	178	236	293	349	403	429	508
	<b>49</b>	<b>47</b>	<b>45</b>	<b>41</b>	<b>38</b>	<b>34</b>	<b>31</b>	<b>29</b>	<b>25</b>
[6]	470	1017	1552	2080	2594	3097	3594	3835	4536
<b>22,7</b>	53	115	175	235	293	350	406	433	513
	<b>74</b>	<b>72</b>	<b>69</b>	<b>66</b>	<b>62</b>	<b>57</b>	<b>52</b>	<b>49</b>	<b>42</b>
[8]	423	967	1502	2031	2549	3062	3563	3807	4526
<b>30,3</b>	48	109	170	229	288	346	403	430	511
	<b>100</b>	<b>98</b>	<b>95</b>	<b>92</b>	<b>88</b>	<b>83</b>	<b>77</b>	<b>73</b>	<b>64</b>
[10]	357	901	1433	1961	2477	2989	3486	3730	4456
<b>37,9</b>	40	102	162	222	280	338	394	421	504
	<b>126</b>	<b>124</b>	<b>121</b>	<b>118</b>	<b>113</b>	<b>108</b>	<b>101</b>	<b>97</b>	<b>87</b>
[12]	287	826	1357	1884	2402	2917	3410	3652	4363
<b>45,4</b>	32	93	153	213	271	330	385	413	493
	<b>152</b>	<b>150</b>	<b>147</b>	<b>144</b>	<b>140</b>	<b>134</b>	<b>126</b>	<b>121</b>	<b>109</b>
[14]	199	733	1261	1786	2303	2818	3316	3561	4276
<b>53,0</b>	22	83	142	202	260	318	375	402	483
	<b>177</b>	<b>176</b>	<b>173</b>	<b>170</b>	<b>165</b>	<b>160</b>	<b>152</b>	<b>147</b>	<b>134</b>
[15]	154	688	1218	1742	2258	2771	3273	3518	4241
<b>56,8</b>	17	78	138	197	255	313	370	398	479
	<b>190</b>	<b>189</b>	<b>186</b>	<b>183</b>	<b>178</b>	<b>173</b>	<b>165</b>	<b>160</b>	<b>146</b>
[20]		418	945	1471	1986	2502	3004	3253	3997
<b>75,7</b>		47	107	166	224	283	339	368	452
		<b>253</b>	<b>251</b>	<b>248</b>	<b>244</b>	<b>239</b>	<b>231</b>	<b>226</b>	<b>212</b>

### S Motor 372 cm<sup>3</sup>/r [22.7 in<sup>3</sup>/r]

Δ Pressure Bar [PSI]

	[200]	[400]	[600]	[800]	[1000]	[1200]	[1400]	[1500]
	<b>14</b>	<b>28</b>	<b>41</b>	<b>55</b>	<b>69</b>	<b>83</b>	<b>97</b>	<b>110</b>
[2]	629	1287	1905	2501	3066	3624	3886	4370
<b>7,6</b>	71	145	215	283	346	409	439	494
	<b>19</b>	<b>18</b>	<b>16</b>	<b>14</b>	<b>13</b>	<b>11</b>	<b>9</b>	<b>7</b>
[4]	628	1304	1962	2600	3206	3799	4082	4642
<b>15,1</b>	71	147	222	294	362	429	461	525
	<b>40</b>	<b>38</b>	<b>36</b>	<b>34</b>	<b>30</b>	<b>27</b>	<b>25</b>	<b>23</b>
[6]	587	1261	1926	2578	3203	3813	4112	4687
<b>22,7</b>	66	142	218	291	362	431	465	530
	<b>60</b>	<b>59</b>	<b>56</b>	<b>54</b>	<b>50</b>	<b>45</b>	<b>43</b>	<b>38</b>
[8]	529	1201	1867	2518	3148	3769	4072	4657
<b>30,3</b>	60	136	211	285	356	426	460	526
	<b>81</b>	<b>79</b>	<b>77</b>	<b>75</b>	<b>71</b>	<b>66</b>	<b>64</b>	<b>58</b>
[10]	451	1124	1779	2429	3056	3678	3983	4583
<b>37,9</b>	51	127	201	274	345	416	450	518
	<b>102</b>	<b>100</b>	<b>98</b>	<b>96</b>	<b>92</b>	<b>86</b>	<b>84</b>	<b>78</b>
[12]	359	1030	1688	2333	2963	3587	3889	4482
<b>45,4</b>	41	116	191	264	335	405	439	506
	<b>122</b>	<b>121</b>	<b>119</b>	<b>117</b>	<b>113</b>	<b>107</b>	<b>104</b>	<b>98</b>
[14]	256	922	1577	2226	2864	3487	3787	4381
<b>53,0</b>	29	104	178	252	324	394	428	495
	<b>143</b>	<b>142</b>	<b>140</b>	<b>137</b>	<b>134</b>	<b>128</b>	<b>126</b>	<b>119</b>
[15]	199	862	1514	2167	2797	3424	3727	4322
<b>56,8</b>	22	97	171	245	316	387	421	488
	<b>153</b>	<b>152</b>	<b>150</b>	<b>148</b>	<b>144</b>	<b>138</b>	<b>135</b>	<b>129</b>
[20]		534	1187	1832	2470	3093	3402	4004
<b>75,7</b>		60	134	207	279	349	384	452
		<b>204</b>	<b>202</b>	<b>200</b>	<b>197</b>	<b>192</b>	<b>189</b>	<b>183</b>



# S Series (103-)

## Dimensions

(Refer to pages B-4-19 thru B-4-22 for shaft and port dimensions.)

## Ports

7/8-14 SAE O-Ring

6-1/2 (BSP) Straight thread manifold

## Standard Rotation Viewed from Shaft End

Port A Pressurized — CW

Port B Pressurized — CCW

## 2 Bolt Flange

82,55/82,42  
[3.250/3.245]  
Pilot Dia.

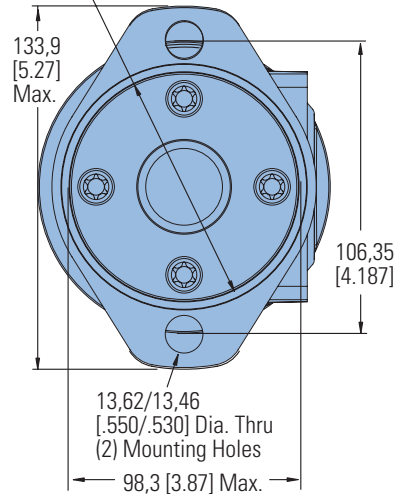

Groove Provided for 82,6 [3.25] I.D. x 2,62 [1.03] Cross Section O-ring ( Dash No. 152)

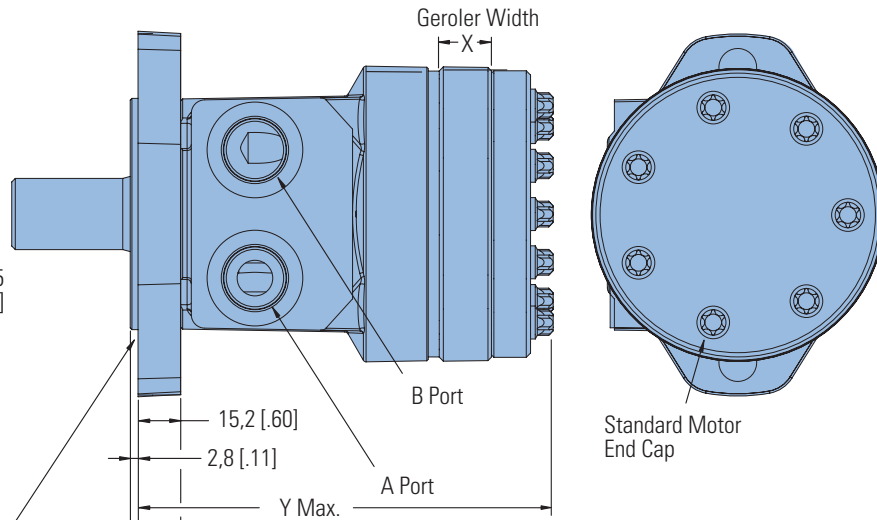

Standard Motor End Cap

## 4 Bolt Flange

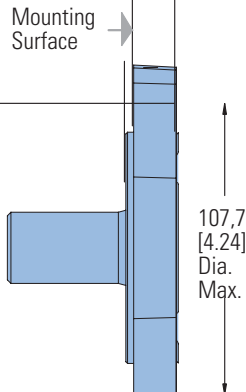
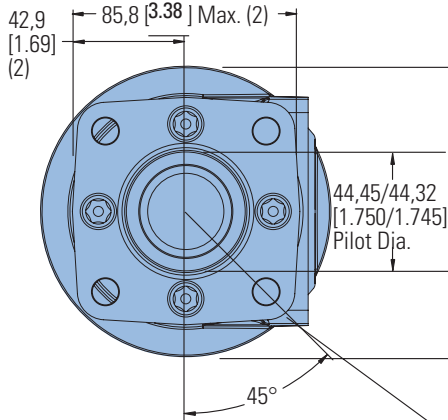

3/8-16 UNC (15,2 [.60] Max. Bolt Thread Engagement) Mounting Holes (4) Equally Spaced on 82,6 [3.25] Dia. Bolt Circle or M10 x 1,5 (15,2 [.60] Max. Bolt Thread Engagement ) Mounting Holes (4) Equally Spaced on 82,6 [3.25] Dia. Bolt Circle

Displacement cm <sup>3</sup> /r [in <sup>3</sup> /r]	X mm [inch]	Y mm [inch]
58 [3.6]	7,5 [.30]	138,0 [5.43]
76 [4.6]	9,8 [.39]	140,3 [5.52]
93 [5.7]	12,0 [.47]	142,5 [5.61]
120 [7.3]	15,5 [.61]	146,0 [5.75]
144 [8.8]	18,6 [.73]	149,1 [5.87]
165 [10.1]	21,3 [.84]	151,8 [5.98]
186 [11.4]	24,0 [.94]	154,5 [6.08]
225 [13.7]	28,9 [1.14]	159,4 [6.28]
299 [18.2]	38,5 [1.52]	169,0 [6.66]
371 [22.7]	47,9 [1.88]	178,4 [7.02]

# S Series (103-)

## Product Numbers

Use three-digit prefix (103-) plus four-digit number from charts for complete product number (ex: 103-1093). Orders will not be accepted without the three-digit prefix.

B-3

### 2 Bolt Flange

SHAFT	PORT SIZE	DISPL. cm <sup>3</sup> /r [in <sup>3</sup> /r] / PRODUCT NUMBER									
		59 [ 3.6]	75 [ 4.6]	93 [ 5.7]	120 [ 7.3]	144 [ 8.8]	166 [ 10.1]	187 [11.4]	225 [13.7]	298 [18.2]	372 [22.7]
1 in. Straight w/Woodruff Key	7/8-14 O-Ring	103-1537	-1034	-1035	-1538	-1539	-1036	-1037	-1038	-1039	-1040
	1/2 NPTF	103-1540	-1026	-1027	-1541	-1542	-1028	-1029	-1030	-1031	-1032
	Manifold	103-1543	-1042	-1043	-1544	-1545	-1044	-1045	-1046	-1047	-1048
1 in. SAE 6B Splined	7/8-14 O-Ring	103-1552	-1082	-1083	-1553	-1554	-1084	-1085	-1086	-1087	-1088
	1/2 NPTF	103-1555	-1074	-1075	-1556	-1557	-1076	-1077	-1078	-1079	-1080
	Manifold	103-1558	-1090	-1091	-1559	-1560	-1092	-1093	-1094	-1095	-1096

103-1093

### 4 Bolt Flange

SHAFT	PORT SIZE	DISPL. cm <sup>3</sup> /r [in <sup>3</sup> /r] / PRODUCT NUMBER									
		59 [ 3.6]	75 [ 4.6]	93 [ 5.7]	120 [ 7.3]	144 [ 8.8]	166 [ 10.1]	187 [11.4]	225 [13.7]	298 [18.2]	372 [22.7]
1 in. Straight w/Woodruff Key	7/8-14 O-Ring	103-1570	-1010	-1011	-1571	-1572	-1012	-1013	-1014	-1015	-1016
	1/2 NPTF	103-1573	-1002	-1003	-1574	-1575	-1004	-1005	-1006	-1007	-1008
	Manifold	103-1576	-1018	-1019	-1577	-1578	-1020	-1021	-1022	-1023	-1024
1 in. SAE 6BSplined	7/8-14 O-Ring	103-1579	-1058	-1059	-1580	-1581	-1060	-1061	-1062	-1063	-1064
	1/2 NPTF	103-1582	-1050	-1051	-1583	-1584	-1052	-1053	-1054	-1055	-1056
	Manifold	103-1585	-1066	-1067	-1586	-1587	-1068	-1069	-1070	-1071	-1072

103-1069

### S Series Motors with Corrosion Protection

SHAFT	MOUNTING	PORT SIZE	DISPL. cm <sup>3</sup> /r [in <sup>3</sup> /r] / PRODUCT NUMBER									
			59 [ 3.6]	75 [ 4.6]	93 [ 5.7]	120 [ 7.3]	144 [ 8.8]	166 [ 10.1]	187 [11.4]	225 [13.7]	298 [18.2]	372 [22.7]
1 in. Straight w/Woodruff Key	2 Bolt Flange	7/8-14 O-Ring	103-1645	-	-	-	-	-	-	-1649	-	-1650
	4 Bolt Flange	1/2 NPTF	-	-	-	-	-	-	-	-1620	-	-1621

\*Manifold product numbers shown are for motors with four 5/16 z-18 port face mounting threads. Manifold, manifold mounting O-Rings and bolts are NOT included.

For S Series Motors with a configuration Not Shown in the charts above: Use the model code number system on page B-3-11 to specify the product in detail.

# S Series with Low Speed Valving

Product Number

Motors with the low speed valving option enable very smooth low speed operation while maintaining high torque.

Designed to run continuously at up to 200 RPM at standard rated pressures and reduced flows, this option provides smooth operation at low speeds. Furthermore, they resist slippage and have

more momentary load holding ability than the standard H and S Series motors. Motors with this valving are not intended for low pressure applications (A minimum of 300 psi delta must be maintained between A port pressure and case pressure). Shaft side / radial load ratings are not affected by this valving.

Use digit prefix—103—plus four digit number from charts for complete product number—Example: 103-2678.

**Orders will not be accepted without the three-digit prefix.**

## 2 Bolt Flange

SHAFT	PORT SIZE	DISPL. cm <sup>3</sup> /r [in <sup>3</sup> /r] / PRODUCT NUMBER									
		59 [ 3.6]	75 [ 4.6]	93 [ 5.7]	120 [ 7.3]	144 [ 8.8]	166 [ 10.1]	187 [ 11.4]	225 [ 13.7]	298 [ 18.2]	372 [ 22.7]
1 in. Straight w/Woodruff Key	7/8 -14 O-Ring	103- —	-1427	-1428	—	—	-1429	-1430	-1431	-1432	-1433
	1/2 NPTF	103- —	-1419	-1420	—	—	-1421	-1422	-1423	-1424	-1425
	Manifold*	103- —	—	—	—	—	—	—	—	—	—
1 in. SAE 6B Splined	7/8 -14 O-Ring	103- —	-1525	—	—	-2692	—	—	-1675	—	—
	1/2 NPTF	103- —	—	-1634	—	—	—	—	—	—	—
	Manifold*	103- —	-1522	-2678	—	—	—	—	—	—	-1527

## 4 Bolt Flange

SHAFT	PORT SIZE	DISPL. cm <sup>3</sup> /r [in <sup>3</sup> /r] / PRODUCT NUMBER										
		59 [ 3.6]	75 [ 4.6]	93 [ 5.7]	120 [ 7.3]	144 [ 8.8]	166 [ 10.1]	187 [ 11.4]	225 [ 13.7]	298 [ 18.2]	372 [ 22.7]	
1 in. Straight w/Woodruff Key	7/8 -14 O-Ring		103-1625	-1410	-1411	-1626	-2531	-1412	-1413	-1414	-1415	-1416
	1/2 NPTF	103-1644	-1402	-1403	—	—	-1404	-1405	-1406	-1407	-1408	

103-1404

103-1527

\*Manifold product numbers shown are for motors with four 5/16 -18 port face mounting threads. Manifold, manifold mounting O-Rings and bolts are NOT included.

For S Series Motors with Low Speed Valving Not Shown in the chart above: Use the model code number system on page B-3-11 to specify the product in detail.

# S Series (103-)

Model Code

The following 30-digit coding system has been developed to identify all of the configuration options for the S motor. Use this model code to specify a motor with the desired features. All 30-digits of the code must be present when ordering. You may want to photocopy the matrix below to ensure that each number is entered in the correct box.

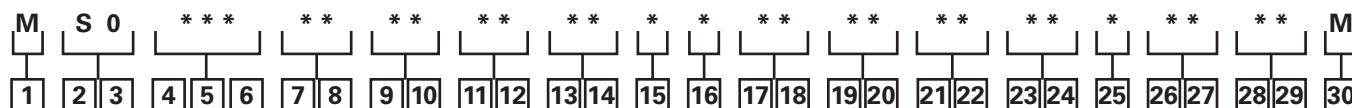

## 1 Product

M – Motor

## 2, 3 Series

S0 – S Series Motor

## 4, 5, 6 Displacement cm<sup>3</sup>/r [in<sup>3</sup>/r]

036 – 58 [3.6]

046 – 76 [4.6]

057 – 93 [5.7]

073 – 120 [7.3]

088 – 144 [8.8]

101 – 165 [10.1]

114 – 186 [11.4]

137 – 224 [13.7]

182 – 299 [18.2]

227 – 371 [22.7]

## 7, 8 Mounting Type

AA – 2 Bolt Std: 82.50 [3.248] Dia. x 3.05 [.120] Pilot, 13.59 [.535] Dia. Mounting Holes on 106.35 [4.187] Dia. B.C.

BA – 4 Bolt Std: 44.40 [1.748] Dia. x 3.05 [.120] Pilot, .375-16 UNC-2B Mounting Holes on 82.55 [3.250] Dia. B.C.

CA – 2 Bolt Std: 82.50 [3.248] Dia. x 6.10 [.240] Pilot, 10.41 [.410] Dia. Mounting Holes on 106.35 [4.187] Dia. B.C. (SAE A)

DD – 2 Bolt Std: 101.60 [4.000] Dia. x 6.10 [.240] Pilot, 14.35 [.565] Dia. Mounting Holes on 146.05 [5.750] Dia. B.C. (SAE B) (Ductile)

EA – 4 Bolt Magneto: 82.50 [3.248] Dia. x 3.05 [.120] Pilot, 13.59 [.535] Dia. Mounting Holes on 106.35 [4.187] Dia. B.C.

FA – 4 Bolt Std: 44.40 [1.748] Dia. x 3.05 [.120] Pilot, M10 x 1.5-6h Mounting Holes on 82.55 [3.250] Dia. B.C.

LA – 2 Bolt Std: 44.45 [1.750]

Dia. x 3.05 [.120] Pilot, 13.59 [.535] Dia. Mounting Holes on 106.35 [4.187] Dia. B.C.

MA – 2 Bolt (Standard) 82.50 [3.248] Dia. x 8.13 [.320] Pilot, 13.59 [.535] Dia. Mounting Holes on 106.35 [4.187] Dia. B.C., w/o O-ring Groove

## 9, 10 Output Shaft

01 – 25.4 [1.00] Dia. Straight, Woodruff Key, .250-20 UNC-2B Hole in Shaft End

02 – 25.4 [1.00] Dia. SAE 6B Spline, .250-20 UNC-2B Hole in Shaft End

07 – 25.4 [1.00] Dia. Straight, 8.03 [.316] Dia. Crosshole 11.2 [.44] From End, 5.6 [.22] Extra Length

08 – 25.4 [1.00] Dia. Straight, 10.31 [.406] Dia. Crosshole 15.7 [.62] From End, .250-20 UNC-2B Hole in Shaft End

16 – 22.22 [.875] Dia. SAE 13 Tooth Spline (SAE B)

17 – 22.22 [.875] Dia. Straight, 6.4 [.25] x 19.0 [.75] Square Key (SAE B)

18 – 25.4 [1.00] Dia. Tapered, Woodruff Key and Nut, 34.92 [1.375] Taper Length

24 – 25.00 [.984] Dia. Straight, 8.00 [.315] Key, M8 x 1.25-6H Hole in Shaft End

39 – 25.00 [.984] Dia. Straight (k6), 8.00 [.315] Key, M8 x 1.25-6H Hole in Shaft End

## 11, 12 Port Type

AA – .875-14 UNF-2B SAE O-Ring Ports

AB – .500-14 NPTF Dryseal Pipe Thread Ports

AC – Manifold Ports (.3125-18 UNC-2B Mounting Holes)

AD – Manifold Ports (M8 x 1.25-6H Mounting Holes)

AF – G 1/2 BSP Straight Thread Ports

## 13, 14 Case Flow Options ††

00 – None Specified

01 – 4375-20 UNF-2B SAE O-Ring Port (End Cap)

02 – G 1/4 BSP Straight THD Port (End Cap)

03 – Manifold Case Drain

04 – .4375-20 UNF-2B SAE O-RING PORT (SIDE OF HOUSING)

05 – .3125-24 UNF-2B SAE O-RING PORT (MOUNTING FLANGE)

11 – Internal Check Valves

†† – Internal check valves are standard features.

## 15 Geroler® Options

0 – None Specified

## 16 Shaft Options

0 – None Specified

N – Electroless Nickel Plated

## 17, 18 Seal Options

00 – Standard Seals

02 – Seal Guard

03 – Viton Seals

04 – Viton Shaft Seal

07 – High Pressure Shaft Seal

11 – High pressure shaft seal, slinger seal

19 – Extreme duty seal guard

## 19, 20 Speed Sensor Options

00 – None

AA – Speed Sensor Options 12mm Digital Speed Pickup (15 pulse) without lead wire

AB – Magnetic Speed Pickup (60 Pulse by Quadrature), No lead wire with M12 connector (A=Power, B=Common, C=Signal)

## 21, 22 Manifold Block Options

00 – None

\* Contact your Eaton sales representative for available options.

## 23, 24 Special Features (Hardware)

00 – None Specified

AB – Low Speed Valving

SS – Stainless Steel Flange Bolts

## 25 Special Assembly Instructions

0 – None

1 – Reverse Rotation

2 – Flange Rotated 90°

3 – Reverse Rotation, Flange Rotated 90°

## 26, 27 Paint/Packaging Options

00 – No Paint

AA – Low Gloss Black Primer

AD – Environmental Coated Gloss White

AF – Environmental Coated Black

## 28, 29 Eaton Assigned Code When Applicable

00 – Assigned Code

## 30 Eaton Assigned Design Code

M – Twelve (12)

Feature in **bold** are preferred and allow for shorter lead time.

# Notes

# T Series (158-)

## Highlights

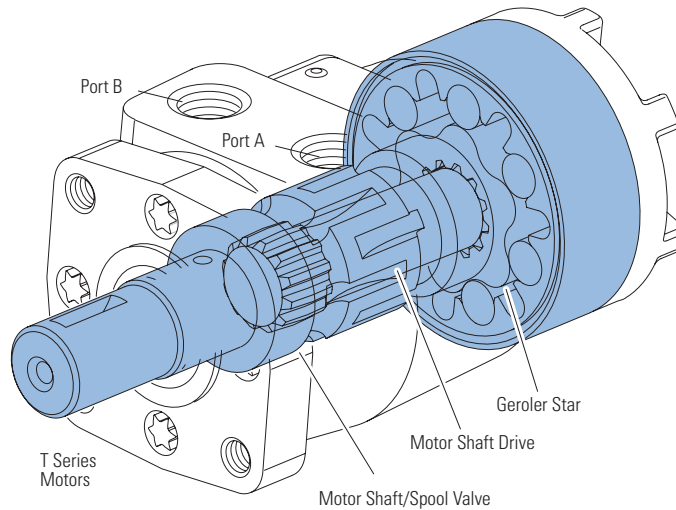

### Description

The newest Geroler motor, the "T Series, features the latest innovations in Geroler technology. These innovations include optimized Geroler geometry with lower drive running angle for improved life and improved low speed performance. In addition, the improved housing and smaller diameter end cap results in increased envelope rigidity which improves efficiency under high pressure loads. All of these innovations come together to make the T Series motor the highest performing motor in its class.

### Specifications for T Series Motors

Geroler Element	11 Displacements
Flow l/min [GPM]	55 [15] Continuous*** 75 [20] Intermittent**
Speed	Up to 1021 RPM
Pressure bar [PSI]	155 [2250] Cont.*** 190 [2750] Inter.**
Torque Nm [lb-in]	441 [3905] Cont.*** 486 [4300] Inter.**

\*\*\* Continuous— (Cont.) Continuous rating, motor may be run continuously at these ratings.

\*\* Intermittent— (Inter.) Intermittent operation, 10% of every minute.

### Features:

- Constant clearance Geroler, geometry
- Optimized drive system with reduced running angle
- Three-pressure zone design (ability to reduce case pressure)
- Variety of displacements, shafts and mounts
- Special options to meet customer needs

### Benefits:

- High efficiency
- Smooth low-speed operation
- Extended motor life (especially at low speed conditions)
- Design flexibility
- Ability to optimize designs for your application needs
- Extends leak-free performance

### Applications:

- Agricultural augers, harvesters, seeders
- Car wash brushes
- Food processing
- Railroad maintenance equipment
- Machine tools
- Conveyors
- Industrial sweepers and floor polishers
- Saw mill works
- Turf equipment
- Concrete and asphalt equipment
- Skid steer attachments
- Many more

B-4



Crane (winch)



Paving



Harvester



Crane and winches

# T Series (158-, 185-)

## Specifications

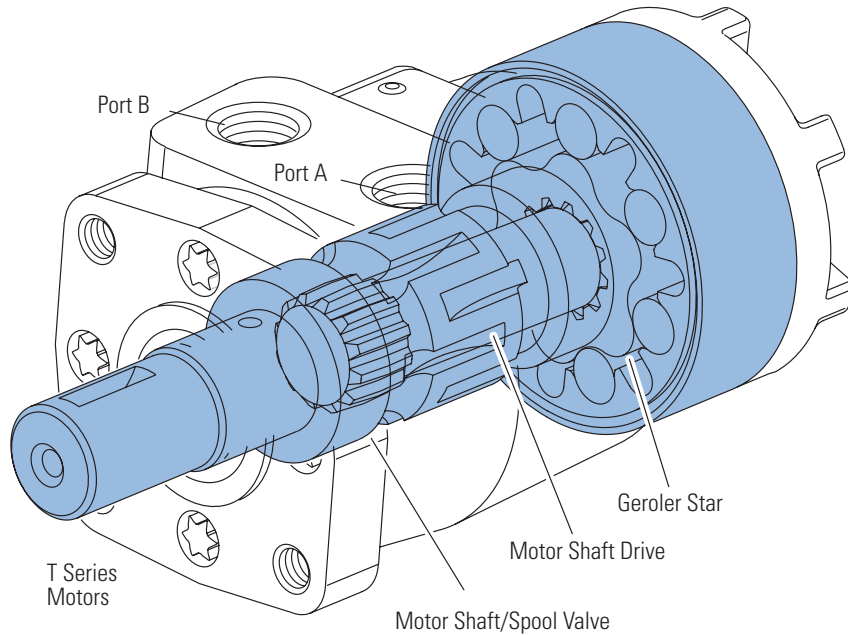

### SPECIFICATION DATA – T MOTORS

Displ. cm <sup>3</sup> /r [in <sup>3</sup> /r]		36 [2.2]	49 [3.0]	66 [4.0]	80 [4.9]	102 [6.2]	131 [8.0]	157 [9.6]	195 [11.9]	244 [14.9]	306 [18.7]	370 [22.6]
Max. Speed (RPM) @ Continuous Flow		1021	906	849	694	550	426	355	287	229	183	152
Flow LPM [GPM]	Continuous Intermittent	38 [10] 38 [10]	45 [12] 57 [15]	57 [15] 68 [18]	57 [15] 76 [20]	57 [15] 76 [20]	57 [15] 76 [20]	57 [15] 76 [20]	57 [15] 76 [20]	57 [15] 76 [20]	57 [15] 76 [20]	57 [15] 76 [20]
Torque Nm [lb-in]	Continuous Intermittent **	76 [672]	105 [928]	138 [1222]	174 [1541]	219 [1936]	251 [2226]	297 [2628]	359 [3178]	410 [3633]	441 [3905]	430 [3811]
		93 [824]	118 [1131]	168 [1488]	212 [1872]	264 [2339]	307 [2718]	359 [3178]	437 [3864]	485 [4290]	483 [4275]	486 [4300]
Pressure Δ Bar Δ PSI]	Continuous* Intermittent**	155 [2250]	155 [2250]	155 [2250]	155 [2250]	155 [2250]	138 [2000]	138 [2000]	138 [2000]	127 [1850]	110 [1600]	90 [1300]
		190 [2750]	190 [2750]	190 [2750]	190 [2750]	190 [2750]	172 [2500]	172 [2500]	172 [2500]	155 [2250]	124 [1800]	103 [1500]

A simultaneous maximum torque and maximum speed NOT recommended.

#### Note:

To assure best motor life, run motor for approximately one hour at 30% of rated pressure before application to full load. Be sure motor is filled with fluid prior to any load applications.

#### Maximum Inlet Pressure:

190 Bar [2750 PSI] without regard to Δ Bar [D PSI] and/or back pressure ratings or combination thereof.

6B splined or Tapered shafts are recommended whenever operation above 282 NM [2500 lb-in] of torque, especially for those applications subject to frequent reversals.

#### Δ Pressure:

The true Δ bar [Δ PSI] between inlet port and outlet port

#### Continuous Rating:

Motor may be run continuously at these ratings

#### Intermittent Operation:

10% of every minute

#### Recommended Fluids:

Premium quality, anti-wear type hydraulic oil with a viscosity of not less than 70 SUS at operating temperature.

#### Recommended System Operating Temp.:

-34°C to 82°C [-30°F to 180°F]

#### Recommended Filtration:

per ISO Cleanliness Code 4406, level 20/18/13



# T Series

## (158-, 185-)

### Performance Data

Motors run with high efficiency in all areas designated with a number for torque and speed. For best motor life select a motor to run with a torque and speed range shown in the light shaded area.

Performance data is typical at 120 SUS. Actual data may vary slightly from unit to unit in production.

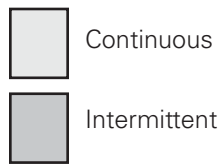

**36 cm<sup>3</sup>/r [2.2 in<sup>3</sup>/r]**  
Δ Pressure Bar [PSI]  
Continuous

	[200]	[400]	[600]	[800]	[1000]	[1200]	[1400]	[1600]	[1800]	[2000]	[2200]	[2250]	Max. Continuous	Max. Intermittent
	[200] 14	[400] 28	[600] 41	[800] 55	[1000] 69	[1200] 83	[1400] 97	[1600] 110	[1800] 124	[2000] 138	[2200] 152	[2250] 155	[2750] 190	[2750] 190
Flow LPM [GPM]	[2] 7.6	[50] 6 209	[110] 12 203	[172] 19 197	[233] 26 191	[291] 33 189	[348] 39 181	[401] 45 167	[455] 51 164	[501] 57 153	[546] 62 139	[590] 67 122	[596] 67 116	[635] 72 64
	[4] 15.1	[50] 6 415	[109] 12 411	[172] 19 398	[233] 26 388	[296] 33 384	[355] 40 381	[414] 47 368	[475] 54 357	[534] 60 354	[584] 66 323	[646] 73 304	[659] 74 302	[786] 89 283
	[6] 22.7	[43] 5 617	[108] 12 613	[171] 19 602	[233] 26 595	[298] 34 585	[361] 41 570	[420] 47 563	[479] 54 558	[538] 61 534	[595] 67 520	[657] 74 504	[672] 76 496	[824] 93 425
	[8] 30.3	[39] 4 821	[101] 11 815	[164] 19 803	[226] 26 797	[292] 33 784	[354] 40 774	[415] 47 758	[475] 54 747	[538] 61 732	[592] 67 707	[656] 74 688	[670] 76 680	[819] 92 607
Max. Continuous 37.9	[30] 3 1021	[93] 11 1014	[155] 18 1002	[214] 24 999	[278] 31 981	[342] 39 965	[406] 46 953	[473] 53 937	[532] 60 921	[590] 67 903	[650] 73 880	[668] 75 873	[805] 91 799	



**49 cm<sup>3</sup>/r [3.0 in<sup>3</sup>/r]**  
Δ Pressure Bar [PSI]  
Continuous

	[200]	[400]	[600]	[800]	[1000]	[1200]	[1400]	[1600]	[1800]	[2000]	[2200]	[2250]	Max. Continuous	Max. Intermittent
	[200] 14	[400] 28	[600] 41	[800] 55	[1000] 69	[1200] 83	[1400] 97	[1600] 110	[1800] 124	[2000] 138	[2200] 152	[2250] 155	[2750] 190	[2750] 190
Flow LPM [GPM]	[2] 7.6	[73] 8 152	[161] 18 152	[245] 28 148	[327] 37 147	[408] 46 142	[486] 55 141	[563] 64 134	[641] 72 124	[710] 80 115	[786] 89 109	[849] 96 95	[866] 98 92	[1023] 116 58
	[4] 15.1	[72] 8 303	[160] 18 298	[246] 28 294	[329] 37 290	[416] 47 276	[500] 56 273	[584] 66 265	[668] 75 261	[746] 84 245	[825] 93 243	[901] 102 235	[922] 104 228	[1123] 127 152
	[6] 22.7	[58] 7 461	[148] 17 450	[234] 26 445	[326] 37 438	[413] 47 434	[500] 56 421	[583] 66 419	[663] 75 410	[746] 84 407	[827] 93 389	[909] 103 376	[928] 105 373	[1131] 128 344
	[8] 30.3	[44] 5 607	[127] 14 603	[216] 24 600	[306] 35 590	[392] 44 583	[480] 54 576	[566] 64 564	[652] 74 554	[734] 83 545	[815] 92 536	[897] 101 522	[917] 104 520	[1125] 127 503
Max. Continuous 37.9	[39] 4 755	[128] 14 750	[213] 24 745	[302] 34 738	[391] 44 732	[477] 54 719	[562] 63 713	[647] 73 702	[731] 83 696	[815] 92 682	[897] 101 663	[917] 104 661	[1121] 127 638	
	[12] 4 45.4	[33] 4 906	[119] 13 902	[203] 23 895	[291] 33 883	[378] 43 875	[464] 52 862	[551] 62 859	[635] 72 844	[719] 81 835	[802] 91 819	[883] 100 806	[900] 102 804	[1061] 120 788
Max. Intermittent 56.8	[26] 3 1132	[86] 10 1124	[172] 19 1113	[256] 29 1115	[342] 39 1106	[430] 49 1106	[505] 57 1098	[591] 67 1093	[674] 76 1079	[745] 84 1070	[830] 94 1058	[851] 96 1056		

# T Series

## (158-, 185-)

### Performance Data

Motors run with high efficiency in all areas designated with a number for torque and speed. For best motor life select a motor to run with a torque and speed range shown in the light shaded area.

Performance data is typical at 120 SUS. Actual data may vary slightly from unit to unit in production.

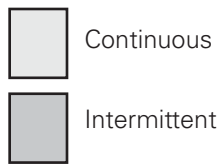

		66 cm <sup>3</sup> /r [4.0 in <sup>3</sup> /r]											Max. Continuous	Max. Intermittent
		Pressure Bar [PSI]												
		Continuous												
		[200]	[400]	[600]	[800]	[1000]	[1200]	[1400]	[1600]	[1800]	[2000]	[2200]	[2250]	[2750]
		14	28	41	55	69	83	97	110	124	138	152	155	190
Flow LPM [GPM]	[2]	[78]	[191]	[303]	[414]	[522]	[625]	[706]	[804]	[898]	[991]	[1081]	[1103]	[1318]
	7,6	9 114	22 111	34 110	47 107	59 105	71 101	80 96	91 92	101 87	112 81	122 73	125 72	149 48
	[4]	[97]	[209]	[325]	[441]	[548]	[657]	[766]	[873]	[972]	[1077]	[1181]	[1205]	[1437]
	15,1	11 229	24 229	37 217	50 216	62 212	74 205	87 194	99 190	111 186	122 183	133 181	136 178	162 170
	[6]	[79]	[192]	[309]	[426]	[534]	[649]	[760]	[874]	[984]	[1090]	[1190]	[1218]	[1488]
	22,7	9 344	22 343	35 335	48 334	60 321	73 320	86 319	99 315	111 291	123 288	134 279	138 276	168 270
	[8]	[75]	[191]	[304]	[419]	[532]	[645]	[759]	[871]	[982]	[1092]	[1197]	[1222]	[1458]
	30,3	8 456	22 451	34 447	47 442	60 431	73 426	86 419	98 415	111 412	123 401	135 391	138 386	165 339
	[10]	[49]	[163]	[283]	[398]	[509]	[623]	[742]	[856]	[971]	[1080]	[1186]	[1209]	[1425]
	37,9	6 569	18 565	32 560	45 552	58 547	70 541	84 532	97 525	110 512	122 504	134 498	137 496	161 475
[12]	[24]	[156]	[270]	[385]	[502]	[614]	[729]	[845]	[963]	[1067]	[1182]	[1209]	[1472]	
45,4	3 681	18 678	31 671	43 665	57 658	69 651	82 641	95 635	109 623	121 612	134 604	137 601	166 571	
[14]	[19]	[143]	[261]	[370]	[485]	[602]	[718]	[837]	[948]	[1064]	[1175]	[1199]	[1436]	
53,0	2 793	16 788	29 787	42 778	55 771	68 762	81 753	95 746	107 733	120 723	133 715	135 711	162 677	
[15]	[13]	[120]	[236]	[352]	[471]	[590]	[707]	[823]	[939]	[1052]	[1165]	[1192]	[1462]	
Max. Continuous	56,8	1 849	14 844	27 839	40 832	53 826	67 819	80 806	93 800	106 786	119 779	132 770	135 766	165 725
Max. Intermittent	[18]		[107]	[215]	[326]	[442]	[555]	[669]	[786]	[900]	[1016]	[1123]	[1152]	
	68,1		12 1006	24 1003	37 998	50 988	63 976	76 975	89 965	102 952	115 940	127 924	130 919	

		80 cm <sup>3</sup> /r [4.9 in <sup>3</sup> /r]											Max. Continuous	Max. Intermittent
		Pressure Bar [PSI]												
		Continuous												
		[200]	[400]	[600]	[800]	[1000]	[1200]	[1400]	[1600]	[1800]	[2000]	[2200]	[2250]	[2750]
		14	28	41	55	69	83	97	110	124	138	152	155	190
Flow LPM [GPM]	[2]	[123]	[265]	[405]	[544]	[680]	[804]	[934]	[1052]	[1181]	[1079]	[937]	[895]	
	7,6	14 93	30 90	46 86	61 83	77 80	91 75	106 70	119 63	133 57	122 43	106 24	101 20	
	[4]	[120]	[264]	[406]	[551]	[689]	[828]	[965]	[1101]	[1237]	[1369]	[1505]	[1537]	[1857]
	15,1	14 187	30 185	46 183	62 179	78 175	94 171	109 166	124 162	140 156	155 150	170 142	174 140	210 121
	[6]	[113]	[255]	[398]	[542]	[682]	[823]	[963]	[1101]	[1239]	[1373]	[1508]	[1541]	[1868]
	22,7	13 279	29 275	45 271	61 267	77 265	93 258	109 253	124 248	140 240	155 232	170 223	174 221	211 198
	[8]	[99]	[243]	[386]	[528]	[669]	[812]	[954]	[1094]	[1233]	[1368]	[1503]	[1537]	[1872]
	30,3	11 372	27 367	44 364	60 359	76 354	92 351	108 343	124 338	139 333	155 324	170 315	174 313	212 289
	[10]	[84]	[228]	[371]	[514]	[655]	[798]	[941]	[1080]	[1219]	[1357]	[1496]	[1530]	[1870]
	37,9	9 463	26 460	42 456	58 450	74 446	90 441	106 435	122 428	138 420	153 412	169 403	173 399	211 368
[12]	[63]	[209]	[354]	[498]	[638]	[782]	[926]	[1067]	[1208]	[1346]	[1484]	[1520]	[1864]	
45,4	7 557	24 552	40 547	56 543	72 537	88 530	105 523	121 515	136 509	152 500	168 489	172 487	211 470	
[14]	[55]	[185]	[331]	[476]	[620]	[762]	[904]	[1046]	[1188]	[1327]	[1467]	[1502]	[1842]	
53,0	6 649	21 646	37 642	54 635	70 630	86 622	102 616	118 609	134 599	150 592	166 581	170 578	208 550	
[15]	[51]	[176]	[316]	[463]	[609]	[748]	[891]	[1037]	[1177]	[1316]	[1457]	[1491]	[1844]	
Max. Continuous	56,8	6 694	20 691	36 687	52 680	69 673	85 668	101 660	117 650	133 642	149 634	165 622	168 619	208 598
Max. Intermittent	[20]		[160]	[305]	[455]	[578]	[737]	[857]	[968]	[1144]	[1277]	[1412]	[1446]	
	75,7		18 916	34 910	51 893	65 893	83 875	97 866	109 877	129 843	144 833	160 839	163 836	



# T Series

## (158-, 185-)

### Performance Data

Motors run with high efficiency in all areas designated with a number for torque and speed. For best motor life select a motor to run with a torque and speed range shown in the light shaded area.

Performance data is typical at 120 SUS. Actual data may vary slightly from unit to unit in production.

	Continuous
	Intermittent

		102 cm <sup>3</sup> /r [6.2 in <sup>3</sup> /r]										Max. Continuous	Max. Intermittent	
		Pressure Bar [PSI]												
		Continuous												
		[200]	[400]	[600]	[800]	[1000]	[1200]	[1400]	[1600]	[1800]	[2000]	[2200]	[2250]	[2750]
		14	28	41	55	69	83	97	110	124	138	152	155	190
Flow LPM [GPM]	[2]	[161]	[341]	[519]	[697]	[871]	[1030]	[1193]	[1349]	[1511]	[1496]	[1441]	[1421]	
	7,6	18 73	39 71	59 68	79 66	98 63	116 60	135 56	152 51	171 46	169 36	163 23	161 20	
	[4]	[157]	[340]	[520]	[702]	[879]	[1056]	[1229]	[1401]	[1567]	[1727]	[1889]	[1925]	[2271]
	15,1	18 149	38 146	59 144	79 141	99 138	119 135	139 131	158 128	177 124	195 118	213 111	217 109	257 92
	[6]	[147]	[329]	[510]	[692]	[871]	[1050]	[1227]	[1401]	[1571]	[1731]	[1895]	[1936]	[2339]
	22,7	17 221	37 217	58 214	78 211	98 208	119 204	139 199	158 195	178 190	196 184	214 176	219 174	264 154
	[8]	[132]	[315]	[497]	[675]	[857]	[1038]	[1216]	[1392]	[1564]	[1725]	[1891]	[1932]	[2326]
	30,3	15 294	36 290	56 287	76 284	97 280	117 277	137 271	157 267	177 262	195 255	214 247	218 245	263 220
	[10]	[109]	[293]	[477]	[657]	[839]	[1018]	[1198]	[1374]	[1542]	[1711]	[1878]	[1918]	[2326]
	37,9	12 367	33 363	54 360	74 355	95 351	115 347	135 343	155 337	174 332	193 325	212 318	217 315	263 287
[12]	[84]	[271]	[457]	[638]	[818]	[999]	[1179]	[1354]	[1527]	[1697]	[1858]	[1901]	[2323]	
45,4	9 440	31 436	52 432	72 429	92 424	113 419	133 414	153 409	173 402	192 395	210 386	215 384	262 364	
[14]	[59]	[242]	[428]	[611]	[794]	[974]	[1151]	[1328]	[1502]	[1674]	[1841]	[1883]	[2301]	
53,0	7 513	27 510	48 506	69 501	90 497	110 492	130 487	150 482	170 475	189 469	208 458	213 456	260 428	
Max. Continuous	[15]	[39]	[227]	[411]	[595]	[780]	[957]	[1136]	[1314]	[1486]	[1658]	[1828]	[1869]	[2285]
	56,8	4 550	26 545	46 542	67 537	88 532	108 528	128 522	148 516	168 510	187 502	207 492	211 490	258 463
Max. Intermittent	[20]		[154]	[328]	[515]	[710]	[874]	[1060]	[1243]	[1405]	[1579]	[1763]	[1803]	
	75,7		17 724	37 718	58 720	80 709	99 707	120 696	140 684	159 683	178 670	199 659	204 660	

		131 cm <sup>3</sup> /r [8.0 in <sup>3</sup> /r]									Max. Continuous	Max. Intermittent
		Pressure Bar [PSI]										
		Continuous										
		[200]	[400]	[600]	[800]	[1000]	[1200]	[1400]	[1600]	[1800]	[2000]	[2500]
		14	28	41	55	69	83	97	110	124	138	172
Flow LPM [GPM]	[2]	[219]	[450]	[682]	[915]	[1144]	[1348]	[1561]	[1771]	[1979]	[2159]	
	7,6	25 57	51 55	77 53	103 51	129 49	152 47	176 43	200 40	224 36	244 30	
	[4]	[212]	[449]	[681]	[917]	[1148]	[1376]	[1600]	[1822]	[2025]	[2221]	[2629]
	15,1	24 115	51 113	77 110	104 109	130 107	155 105	181 102	206 99	229 96	251 91	297 75
	[6]	[197]	[435]	[669]	[903]	[1139]	[1370]	[1600]	[1818]	[2032]	[2226]	[2718]
	22,7	22 171	49 168	76 166	102 163	129 160	155 157	181 154	205 150	230 147	252 142	307 125
	[8]	[181]	[417]	[657]	[886]	[1122]	[1359]	[1589]	[1812]	[2022]	[2215]	[2699]
	30,3	20 227	47 225	74 222	100 219	127 217	154 213	180 209	205 206	228 202	250 196	305 175
	[10]	[144]	[389]	[631]	[859]	[1098]	[1330]	[1562]	[1783]	[1993]	[2198]	[2687]
	37,9	16 284	44 281	71 278	97 275	124 271	150 267	176 265	201 261	225 258	248 252	304 231
[12]	[114]	[361]	[605]	[838]	[1075]	[1307]	[1532]	[1755]	[1965]	[2177]	[2671]	
45,4	13 341	41 338	68 334	95 332	121 328	148 325	173 321	198 318	222 312	246 307	302 285	
[14]	[82]	[327]	[569]	[803]	[1042]	[1273]	[1498]	[1722]	[1935]	[2147]	[2655]	
53,0	9 397	37 394	64 391	91 387	118 384	144 361	169 378	195 374	219 370	243 365	300 339	
Max. Continuous	[15]	[66]	[302]	[550]	[785]	[1025]	[1254]	[1480]	[1704]	[1915]	[2119]	[2648]
	56,8	7 426	34 423	62 422	89 415	116 412	142 409	167 405	193 402	216 398	239 392	299 367
Max. Intermittent	[20]		[177]	[429]	[678]	[908]	[1143]	[1375]	[1596]	[1811]	[2017]	
	75,7		20 565	48 560	77 556	103 553	129 549	155 546	180 541	205 536	228 527	

[302] } Torque [lb-in ]  
34 } Nm  
423 } Speed RPM

# T Series

## (158-, 185-)

### Performance Data

Motors run with high efficiency in all areas designated with a number for torque and speed. For best motor life select a motor to run with a torque and speed range shown in the light shaded area.

Performance data is typical at 120 SUS. Actual data may vary slightly from unit to unit in production.

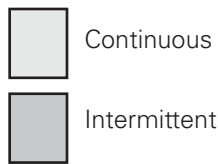

**157 cm<sup>3</sup>/r [9.6 in<sup>3</sup>/r]**

Δ Pressure Bar [PSI]

Continuous

**Max. Continuous**

**Max. Intermittent**

		[200] 14	[400] 28	[600] 41	[800] 55	[1000] 69	[1200] 83	[1400] 97	[1600] 110	[1800] 124	[2000] 138	[2500] 172	
Flow LPM [GPM]	[2] 7,6	[264] 30 47	[541] 61 45	[819] 93 44	[1092] 123 42	[1357] 153 40	[1605] 181 37	[1847] 209 34	[2084] 235 30	[2311] 261 25	[1858] 210 16		
	[4] 15,1	[259] 29 96	[541] 61 95	[822] 93 92	[1101] 124 91	[1373] 155 90	[1638] 185 88	[1890] 214 85	[2145] 242 82	[2383] 269 78	[2613] 295 73	[3063] 346 60	
	[6] 22,7	[241] 27 142	[526] 59 140	[808] 91 138	[1090] 123 136	[1368] 155 134	[1638] 185 132	[1900] 215 129	[2150] 243 125	[2399] 271 121	[2628] 297 114	[3169] 358 99	
	[8] 30,3	[219] 25 189	[506] 57 187	[789] 89 185	[1068] 121 183	[1348] 152 181	[1625] 184 178	[1885] 213 175	[2140] 242 172	[2388] 270 166	[2619] 296 159	[3178] 359 140	
	[10] 37,9	[180] 20 237	[472] 53 234	[759] 86 232	[1037] 117 230	[1319] 149 227	[1590] 180 224	[1853] 209 222	[2111] 239 218	[2355] 266 211	[2594] 293 203	[3170] 358 183	
	[12] 45,4	[141] 16 284	[436] 49 282	[728] 82 279	[1010] 114 277	[1292] 146 274	[1561] 176 272	[1821] 206 269	[2079] 235 265	[2331] 263 257	[2573] 291 248	[3162] 357 225	
	[14] 53,0	[101] 11 332	[397] 45 329	[687] 78 326	[969] 109 323	[1252] 141 321	[1519] 172 319	[1778] 201 316	[2040] 230 311	[2295] 259 305	[2539] 287 296	[3147] 356 274	
	<b>Max. Continuous</b>	[15] 56,8	[81] 9 355	[367] 41 353	[665] 75 350	[944] 107 347	[1231] 139 344	[1497] 169 342	[1755] 198 339	[2018] 228 334	[2273] 257 327	[2512] 284 318	[3136] 354 300
	<b>Max. Intermittent</b>	[20] 75,7		[221] 25 472	[519] 59 467	[814] 92 464	[1095] 124 462	[1368] 155 459	[1631] 184 455	[1891] 214 450	[2149] 243 443	[2396] 271 433	

**195 cm<sup>3</sup>/r [11.9 in<sup>3</sup>/r]**

Δ Pressure Bar [PSI]

Continuous

**Max. Continuous**

**Max. Intermittent**

		[200] 14	[400] 28	[600] 41	[800] 55	[1000] 69	[1200] 83	[1400] 97	[1600] 110	[1750] 121	[1800] 125	[2000] 138	[2500] 172	
Flow LPM [GPM]	[2] 7,6	[330] 37 38	[671] 76 36	[1016] 115 34	[1345] 152 33	[1654] 187 31	[1969] 222 28	[2242] 253 25	[2507] 283 20	[2689] 304 16	[2748] 310 14	[2973] 336 8		
	[4] 15,1	[328] 37 77	[675] 76 77	[1026] 116 75	[1366] 154 73	[1692] 191 73	[2010] 227 71	[2289] 259 68	[2586] 292 65	[2799] 316 62	[2867] 324 61	[3144] 355 55	[3797] 429 40	
	[6] 22,7	[306] 35 115	[658] 74 113	[1011] 114 111	[1360] 154 110	[1698] 192 109	[2021] 228 107	[2324] 263 104	[2604] 294 100	[2829] 320 97	[2901] 328 95	[3178] 359 87	[3831] 433 68	
	[8] 30,3	[272] 31 153	[634] 72 151	[980] 111 150	[1331] 150 148	[1675] 189 146	[2003] 226 144	[2300] 260 142	[2592] 293 139	[2815] 318 134	[2888] 326 132	[3174] 359 123	[3864] 437 99	
	[10] 37,9	[238] 27 192	[596] 67 189	[945] 107 188	[1296] 146 186	[1637] 185 184	[1960] 221 183	[2255] 255 181	[2565] 290 176	[2786] 315 168	[2857] 323 166	[3140] 355 156	[3816] 431 133	
	[12] 45,4	[181] 20 230	[545] 62 228	[908] 103 226	[1260] 142 224	[1607] 182 222	[1924] 217 221	[2223] 251 219	[2529] 286 213	[2759] 312 207	[2836] 320 204	[3121] 353 192	[3807] 430 160	
	[14] 53,0	[154] 17 268	[500] 56 266	[860] 97 264	[1211] 137 261	[1556] 176 259	[1869] 211 259	[2175] 246 256	[2483] 281 251	[2713] 307 244	[2792] 315 242	[3080] 348 229	[3778] 427 199	
	<b>Max. Continuous</b>	[15] 56,8	[140] 16 287	[465] 53 285	[832] 94 283	[1179] 133 281	[1525] 172 279	[1835] 207 278	[2144] 242 275	[2459] 278 269	[2693] 304 262	[2768] 313 260	[3061] 346 247	[3764] 425 220
	<b>Max. Intermittent</b>	[20] 75,7		[291] 33 382	[653] 74 378	[1013] 114 375	[1366] 154 373	[1689] 191 372	[1987] 225 368	[2298] 260 363	[2540] 287 356	[2622] 296 353	[2928] 331 342	



# T Series

## (158-, 185-)

### Performance Data

Motors run with high efficiency in all areas designated with a number for torque and speed. For best motor life select a motor to run with a torque and speed range shown in the light shaded area.

Performance data is typical at 120 SUS. Actual data may vary slightly from unit to unit in production.

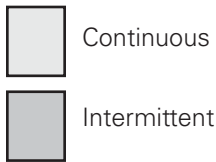

### 244 cm<sup>3</sup>/r [14.9 in<sup>3</sup>/r]

Pressure Bar [PSI]

Continuous

Max. Continuous

Max. Intermittent

		[200]	[400]	[600]	[800]	[1000]	[1200]	[1400]	[1600]	[1800]	[1850]	[2250]
		14	28	41	55	69	83	97	110	114	125	155
Flow LPM [GPM]	[2]	[406]	[833]	[1260]	[1655]	[2038]	[2403]	[2707]	[2597]	[2552]	[2373]	[2299]
	7.6	46 30	94 29	142 27	187 26	230 24	272 22	306 17	293 12	288 11	268 7	260 6
	[4]	[404]	[843]	[1277]	[1695]	[2083]	[2468]	[2820]	[3177]	[3261]	[3509]	[3589]
	15.1	46 62	95 62	144 60	192 59	235 59	279 57	319 55	359 50	368 49	396 46	406 44
	[6]	[382]	[823]	[1261]	[1687]	[2088]	[2477]	[2843]	[3196]	[3285]	[3547]	[3633]
	22.7	43 92	83 91	142 90	191 89	236 88	280 86	321 82	361 78	371 76	401 72	410 71
	[8]	[341]	[787]	[1220]	[1651]	[2059]	[2454]	[2820]	[3177]	[3265]	[3530]	[3615]
	30.3	39 123	89 122	138 121	187 120	233 119	277 116	319 113	359 108	369 106	399 101	408 99
	[10]	[297]	[744]	[1177]	[1611]	[2017]	[2412]	[2774]	[3151]	[3241]	[3504]	[3593]
	37.9	34 154	84 152	133 151	182 150	228 148	273 146	313 143	356 136	366 134	396 127	406 125
[12]	[225]	[687]	[1132]	[1553]	[1967]	[2360]	[2734]	[3105]	[3194]	[3466]	[3554]	
45.4	25 184	78 183	128 181	175 180	222 179	267 177	309 173	351 166	361 163	392 156	402 153	
[14]	[154]	[628]	[1072]	[1498]	[1910]	[2298]	[2674]	[3052]	[3148]	[3419]	[3510]	
53.0	17 214	71 213	121 212	169 211	216 209	260 207	302 202	345 195	356 193	386 185	397 182	
[15]	[119]	[586]	[1035]	[1458]	[1872]	[2261]	[2637]	[3022]	[3116]	[3389]	[3488]	
56.8	13 229	66 228	117 227	165 226	212 224	255 222	298 217	341 209	352 207	383 200	394 197	
Max. Continuous	[20]	[372]	[816]	[1251]	[1663]	[2067]	[2448]	[2832]	[2928]	[3214]	[3312]	
Max. Intermittent	75.7	42 305	92 303	141 301	188 300	234 297	277 292	320 284	331 281	363 273	374 270	

### 306 cm<sup>3</sup>/r [18.7 in<sup>3</sup>/r]

Pressure Bar [PSI]

Continuous

Max. Continuous

Max. Intermittent

		[200]	[400]	[600]	[800]	[1000]	[1200]	[1400]	[1500]	[1600]	[1800]
		14	28	41	55	69	83	97	103	110	124
Flow LPM [GPM]	[2]	[499]	[1035]	[1560]	[2034]	[2501]	[2912]	[3239]	[2859]	[2400]	
	7.6	56 24	117 23	176 22	230 21	283 19	329 16	366 11	323 8	271 5	
	[4]	[497]	[1052]	[1590]	[2101]	[2561]	[3023]	[3464]	[3680]	[3886]	[4221]
	15.1	56 49	119 49	180 48	237 48	289 47	342 47	391 44	416 41	439 38	477 30
	[6]	[480]	[1031]	[1578]	[2096]	[2564]	[3023]	[3464]	[3689]	[3905]	[4275]
	22.7	54 74	116 74	178 72	237 72	290 71	342 69	391 64	417 62	441 60	483 51
	[8]	[427]	[975]	[1520]	[2051]	[2525]	[2998]	[3448]	[3667]	[3881]	[4264]
	30.3	48 99	110 98	172 97	232 97	285 96	339 94	390 89	414 86	438 83	482 73
	[10]	[370]	[930]	[1467]	[2001]	[2477]	[2955]	[3406]	[3631]	[3852]	[4264]
	37.9	42 123	105 122	166 121	226 120	280 120	334 117	385 112	410 108	435 104	482 92
[12]	[281]	[871]	[1410]	[1908]	[2400]	[2887]	[3352]	[3573]	[3790]	[4189]	
45.4	32 147	98 146	159 145	216 145	271 145	326 142	379 136	404 131	428 127	473 112	
[14]	[192]	[791]	[1338]	[1851]	[2338]	[2816]	[3281]	[3511]	[3743]	[4135]	
53.0	22 171	89 171	151 170	209 170	264 169	318 165	371 159	397 154	423 150	467 133	
[15]	[148]	[738]	[1288]	[1803]	[2287]	[2773]	[3243]	[3475]	[3705]	[4098]	
56.8	17 183	83 183	146 182	204 182	258 181	313 177	366 171	393 165	419 160	463 146	
Max. Continuous	[20]	[476]	[1020]	[1544]	[2010]	[2519]	[3010]	[3243]	[3495]		
Max. Intermittent	75.7	54 243	115 242	174 242	227 241	285 238	340 231	366 226	395 209		

[738]  
83 } Torque [lb-in ]  
183 } Nm  
Speed RPM

### 370 cm<sup>3</sup>/r [22.6 in<sup>3</sup>/r]

Pressure Bar [PSI]

Continuous

Max. Continuous

Max. Intermittent

		[200]	[400]	[600]	[800]	[1000]	[1200]	[1300]	[1500]
		14	28	41	55	69	83	90	103
Flow LPM [GPM]	[2]	[590]	[1237]	[1858]	[2406]	[2953]	[3388]	[3586]	
	7.6	67 20	140 19	210 18	272 17	334 15	383 12	405 11	
	[4]	[588]	[1263]	[1906]	[2506]	[3029]	[3557]	[3811]	[4252]
	15.1	66 41	143 41	215 40	283 40	342 39	402 38	431 37	480 36
	[6]	[580]	[1245]	[1899]	[2506]	[3029]	[3544]	[3788]	[4300]
	22.7	66 61	141 60	215 60	283 59	342 58	400 57	428 56	486 54
	[8]	[514]	[1164]	[1824]	[2452]	[2975]	[3518]	[3783]	[4284]
	30.3	58 82	132 81	206 80	277 79	336 78	397 77	427 77	484 75
	[10]	[444]	[1119]	[1759]	[2391]	[2928]	[3479]	[3750]	[4275]
	37.9	50 102	126 102	199 101	270 101	331 100	393 97	424 96	483 93
[12]	[337]	[1062]	[1690]	[2256]	[2813]	[3393]	[3685]	[4273]	
45.4	38 122	120 121	191 120	255 119	318 119	383 118	416 116	483 112	
[14]	[231]	[958]	[1608]	[2201]	[2748]	[3319]	[3610]	[4198]	
53.0	26 142	108 141	182 140	249 139	310 138	375 137	408 134	474 129	
[15]	[178]	[896]	[1543]	[2147]	[2683]	[3272]	[3572]	[4187]	
56.8	20 152	101 152	174 151	243 150	303 149	370 147	404 146	473 140	
Max. Continuous	[20]	[587]	[1228]	[1833]	[2331]	[2948]	[3273]	[3730]	
Max. Intermittent	75.7	66 202	139 201	207 201	263 200	333 198	370 196		

# T Series (158-)

## Dimensions

(Refer to pages B-4-19 thru B-4-22 for shaft and port dimensions.)

## Ports

- 7/8 -14 INF O-Ring Ports (2)
- 1/2 -14 NPTF (2)
- G 1/2 BSP (2)
- Manifold Ports (5/16-18 mounting threads)

## Note:

Mounting Surface Flatness Requirement is  $\nabla$ ,13 mm [.005 inch] Max.

## Standard Rotation Viewed from Shaft End

- Port A Pressurized — CW
- Port B Pressurized — CCW

## 2 Bolt Flange

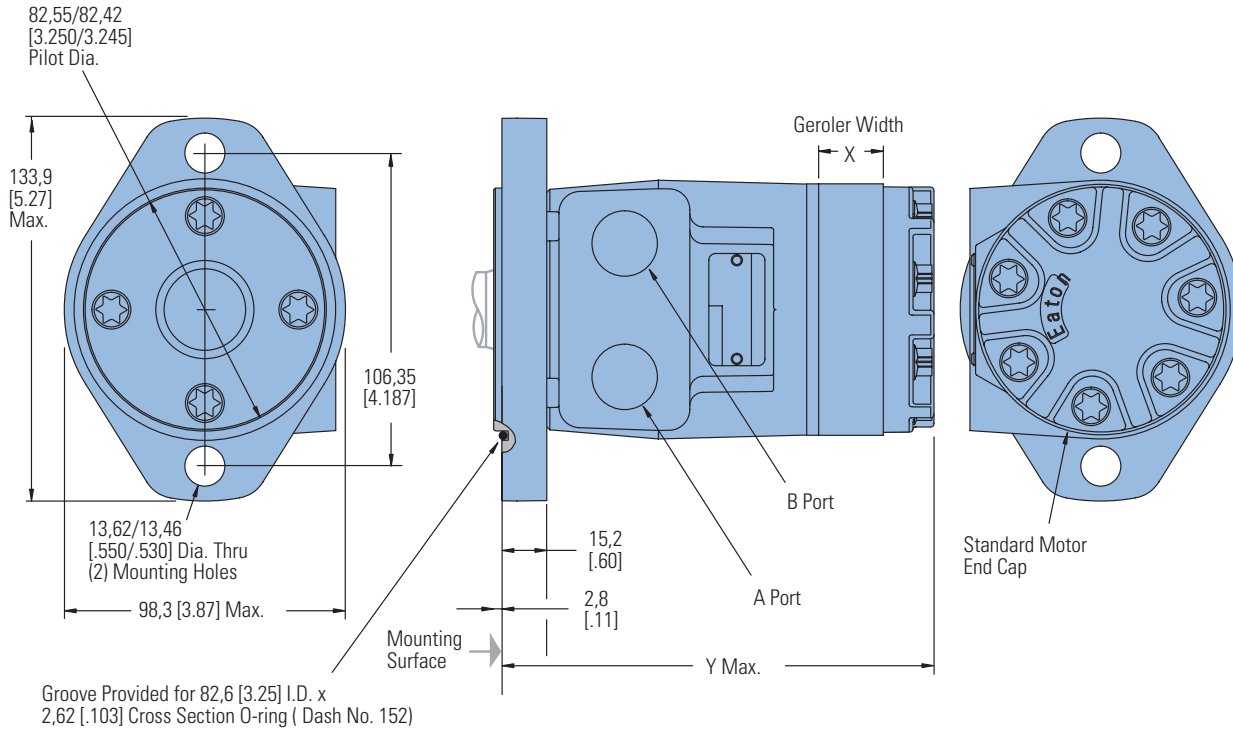

## 4 Bolt Flange

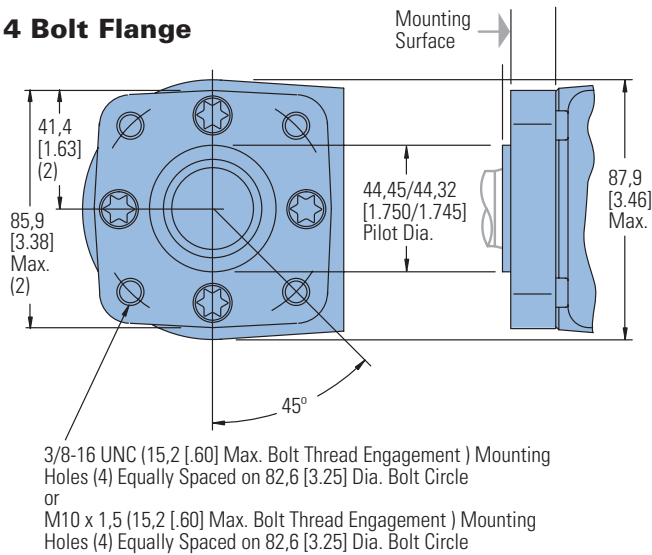

## 2 AND 4 BOLT FLANGE PORT DIMENSIONS

Displacement cm <sup>3</sup> /r [in <sup>3</sup> /r]	X mm [inch]	Y mm [inch]
36 [2.2]	6,6 [.26]	132,2 [5.21]
49 [3.0]	9,1 [.36]	134,6 [5.30]
66 [4.0]	12,2 [.48]	137,7 [5.42]
80 [4.9]	14,7 [.58]	140,3 [5.53]
102 [6.2]	18,5 [.73]	144,3 [5.68]
131 [8.0]	24,1 [.95]	149,6 [5.89]
157 [9.6]	29,0 [1.14]	154,5 [6.09]
195 [11.9]	35,6 [1.40]	161,3 [6.35]
244 [14.9]	44,7 [1.76]	170,3 [6.71]
306 [18.7]	56,1 [2.21]	181,6 [7.16]
370 [22.6]	72,1 [2.84]	197,9 [7.79]

# T Series (158-)

Product Numbers

Use digit prefix—158- plus four digit number from charts for complete product number—Example: 158-1067.

**Orders will not be accepted without the three-digit prefix.**

## Standard

MOUNTING	SHAFT	PORT SIZE	DISPL. cm <sup>3</sup> /r [in <sup>3</sup> /r] / PRODUCT NUMBER											
			36 [2.2]	49 [3.0]	66 [4.0]	80 [4.9]	102 [6.2]	131 [8.0]	157 [9.6]	195 [11.9]	244 [14.9]	306 [18.7]	370 [22.6]	
2 Bolt Flange	1 in. Straight w/Woodruff Key	7/8 -14 O-Ring	158-	—	—	-1537	-1034	-1035	-1538	-1036	-1037	-1038	-1039	-1040
		1/2 NPTF	158-	—	—	-1540	-1026	-1027	-1541	-1028	-1029	-1030	-1031	-1032
		Manifold*	158-	—	—	-1543	-1042	-1043	-1544	-1044	-1045	-1046	-1047	-1048
	1 in. SAE 6B Splined	7/8 -14 O-Ring	158-	—	—	-1552	-1082	-1083	-1553	-1084	-1085	-1086	-1087	-1088
		1/2 NPTF	158-	—	—	-1555	-1074	-1075	-1556	-1076	-1077	-1078	-1079	-1080
		Manifold*	158-	—	—	-1558	-1090	-1091	-1559	-1092	-1093	-1094	-1095	-1096
4 Bolt Flange	1 in. Straight w/Woodruff Key	7/8 -14 O-Ring	158-	—	—	-1570	-1010	-1011	-1571	-1012	-1013	-1014	-1015	-1016
		1/2 NPTF	158-	—	—	-1573	-1002	-1003	-1574	-1004	-1005	-1006	-1007	-1008
		Manifold*	158-	—	—	-1576	-1018	-1019	-1577	-1020	-1021	-1022	-1023	-1024
	1 in. SAE 6B Splined	7/8 -14 O-Ring	158-	—	—	-1579	-1058	-1059	-1580	-1060	-1061	-1062	-1063	-1064
		1/2 NPTF	158-	—	—	-1582	-1050	-1051	-1583	-1052	-1053	-1054	-1055	-1056
		Manifold*	158-	—	—	-1585	-1066	-1067	-1586	-1068	-1069	-1070	-1071	-1072

158-1067

## T Series Motors with Corrosion Protection

MOUNTING	SHAFT	PORT SIZE	DISPL. cm <sup>3</sup> /r [in <sup>3</sup> /r] / PRODUCT NUMBER											
			36 [2.2]	49 [3.0]	66 [4.0]	80 [4.9]	102 [6.2]	131 [8.0]	157 [9.6]	195 [11.9]	244 [14.9]	306 [18.7]	370 [22.6]	
2 Bolt Flange	1 in. Straight w/ Woodruff Key	7/8 -14 O-Ring	158-	—	—	—	1645	—	—	—	—	-1649	—	-1650
4 Bolt Flange		1/2 NPTF	158-	—	—	—	—	—	—	—	—	-1620	—	-1621

158-1620

## T Series Motors with Low Speed Valving

MOUNTING	SHAFT	PORT SIZE	DISPL. cm <sup>3</sup> /r [in <sup>3</sup> /r] / PRODUCT NUMBER											
			36 [2.2]	49 [3.0]	66 [4.0]	80 [4.9]	102 [6.2]	131 [8.0]	157 [9.6]	195 [11.9]	244 [14.9]	306 [18.7]	370 [22.6]	
2 Bolt Flange	1 in. Straight w/Woodruff Key	7/8 -14 O-Ring	158-	—	—	-1427	-1428	—	—	-1430	-1431	-1432	-1433	
		1/2 NPTF	158-	—	—	-1419	-1420	—	—	-1422	-1423	-1424	-1425	
		Manifold*	158-	—	—	—	—	—	—	—	—	—	—	
4 Bolt Flange	1 in. SAE 6B Splined	7/8 -14 O-Ring	158-	—	—	-1525	—	—	—	—	-1675	—	—	
		1/2 NPTF	158-	—	—	—	-1634	—	—	—	—	—	—	
		Manifold*	158-	—	—	-1522	-2678	—	—	—	—	—	-1527	
4 Bolt Flange	1 in. Straight w/ Woodruff Key	7/8 -14 O-Ring	158-	—	—	-1625	-1410	-1411	-1626	-1412	-1413	-1414	-1415	-1416
		1/2 NPTF	158-	—	—	-1644	-1402	-1403	—	-1404	-1405	-1406	-1407	-1408

158-1403

\*Manifold product numbers shown are for motors with four 5/16-18 port face mounting threads. Manifold, manifold mounting O-Rings and bolts are NOT included.

For T Series Motors with a configuration Not Shown in the charts above: Use the model code system on page B-4-10 to specify the product in detail.

# T Series (158-)

## Model Code

The following 30-digit coding system has been developed to identify all of the configuration options for the T motor. Use this model code to specify a motor with the desired features. All 30-digits of the code must be present when ordering. You may want to photocopy the matrix below to ensure that each number is entered in the correct box.

M	T	0	***	**	**	**	**	**	*	*	**	**	**	**	*	**	**	**	A										
1	2	3	4	5	6	7	8	9	10	11	12	13	14	15	16	17	18	19	20	21	22	23	24	25	26	27	28	29	30

### 1 Product

M – Motor

### 2, 3 Product Series

T0 – T Series

### 4, 5, 6 Displacement

cm<sup>3</sup>/r [in<sup>3</sup>/r]

022 – 35 [2.2]

030 – 49 [3.0]

040 – 65 [4.0]

049 – 80 [4.9]

062 – 102 [6.2]

080 – 131 [8.0]

096 – 158 [9.6]

119 – 195 [11.9]

149 – 244 [14.9]

187 – 306 [18.7]

226 – 370 [22.6]

### 7, 8 Mounting Type

**AA – 2 Bolt (Standard)**  
82,6 [3.248] Dia. and 3,05 [.120] pilot, 13,59 [.535] Dia. Mounting Holes 106,35 [4.187] Dia. B.C.

**BA – 4 Bolt (Standard)**  
44,40 [1.748] Dia. x 3,05 [.120] pilot, .375-16 UNC-2B Mounting Holes 82,55 [3.250] Dia. B.C.

CA – 2 Bolt (Standard) 82,50 [3.248] Dia. x 6,10 [.240] pilot, 10,41 [.410] Dia. Mounting Holes 106,35 [4.187] Dia. B.C. (SAE A)

DD – 2 Bolt (Std.) 101,60 [4.000] Dia. x 6,10 [.240] pilot, 14,35 [.565] Dia. Mounting Holes 146,05 [5.750] Dia. B.C. (SAE B) (Ductile)

EA – 4 Bolt Magneto 82,50 [3.248] Dia. x 3,05 [.120] Pilot, 13,59 [.535] Dia. Mounting Holes 106,35 [4.187] Dia. B.C.

**FA – 4 Bolt (Standard)**  
44,40 [1.748] Dia. x 3,05 [.120] pilot, M10 x 1.5-6H Mounting Holes on 82,55 [3.250] Dia. B.C.

**MA – 2 Bolt (Standard)**  
82,50 [3.248] Dia. x 8,13 [.320] Pilot, 13,59 [.535] Dia. Mounting Holes on 106,35 [4.187] Dia. B.C., w/o O-ring Groove

### 9, 10 Output Shaft Description

**01 – 25,4 [1.00] Dia. Straight, Woodruff Key, .250-20 UNC-2B Hole in Shaft End**

**02 – 25,4 [1.00] Dia. SAE 6B Spline, .25-20 UNC-2B Hole in Shaft End**

07 – 25,4 [1.00] Dia. Straight, 8,03 [.316] Dia. Crosshole 11,2 [.44] from End, 5,6 [.22] Extra Length

**08 – 25,4 [1.00] Dia. Straight, 10,31 [.406] Dia. Crosshole 15,7 [.62] from End, .250-20 UNC-2B Hole in Shaft End**

**16 – 22,22 [.875] Dia. SAE 13 Tooth Spline (SAE B)**

17 – 22,22 [.875] Straight Dia. 6,4 [2.5] x 19,0 [.75] Square Key (SAE B)

18 – 25,4 [1.00] Dia. Tapered, Woodruff Key and Nut, 34,92 [1.375] Taper Length

**24 – 25,00 [.984] Dia. Straight, 8,0 [.315] Key, MB x 1.25-6H Hole in Shaft End 39 - 25,00 [.984] Dia. Straight (k6), 8,00 [.315] Key, M8 x 1.25-6H Hole in Shaft End**

### 11, 12 Port Type

**AA – .875-14 UNF-2B SAE O-Ring Ports**

**AB – .500-14 NPTF Dryseal Pipe Thread Ports**

**AC – Manifold (.3125-18 UNC-2B Mounting Holes)**

AD – Manifold Ports (MB x 1.25-6H Mounting Holes)

**AF – G 1/2 BSP Straight Thread Ports**

### 13, 14 Case Flow Options

**00 – None Specified**

**01 – .4375-20 UNF-2B SAE O-Ring Port (End Cap)**

**02 – G 1/4 BSP Straight Thread Port (End Cap)**

**03 – MANIFOLD CASE DRAIN**

04 – .4375-20 UNF-2B SAE O-RING PORT (SIDE OF HOUSING)

05 – .3125-24 UNF-2B SAE O-RING PORT (MOUNTING FLANGE)

**11 – Internal Check Valves**

### 15 Geroler® Options

**0 – None**

A – Free Running

### 16 Shaft Options

**0 – None**

N – Electroless Nickel Plated

### 17, 18 Seal Options

**00 – Standard Seals**

02 – Seal Guard

03 – Viton Seals

**04 – Viton Shaft Seal**

**07 – High Pressure Shaft Seal**

11 – High pressure shaft seal, slinger seal

**19 – Extreme duty seal guard**

### 19, 20 Speed Sensor Options

**00 – None**

AA – 12 mm Digital Speed Pickup (15 Pulse) without Lead Wire

AB – Magnetic Speed Pickup (60 Pulse by Quadrature), No Lead Wire with M12 Connector (A=Power, B=Common, C=Signal)

### 21, 22 Valve Options

**0 – None**

### 23, 24 Special Features (Hardware)

**00 – None Specified**

AB – Low Speed Valving  
SS – Stainless Steel Flange Bolts

### 25 Special Assembly Instructions

**0 – None**

A – Reverse Rotation

2 – Flange Rotation 90°

### 26, 27 Paint/Packaging Options

**00 – No Paint**

**AA – Low Gloss Black Primer**

AD – Environmental Coated Gloss White

### 28, 29 Customer ID/ Nameplate Options

**0 – None Specified**

### 30 Design Code

**A – One (1)**

Feature in **bold** are preferred and allow for shorter lead time.



# T Series with Parking Brake (185-)

## Highlights

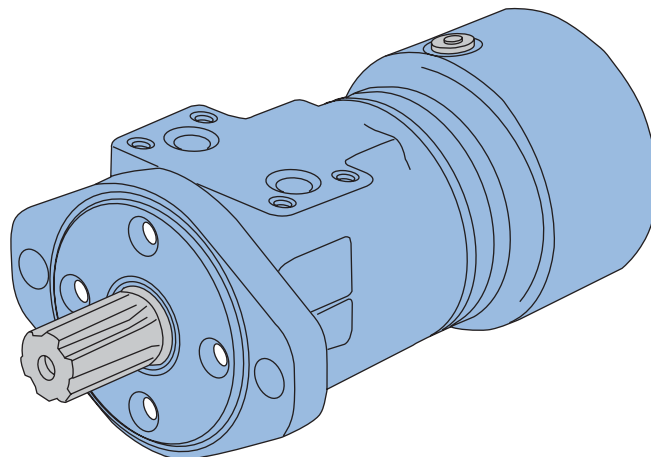

### Description

Eaton's latest offering in LSHT motor technology is the new T Series Motor with Parking Brake.

T Series Motor with Parking Brake utilizes brake pads that rotate at 6 times the speed of the output shaft, thereby giving the brake a 6-to-1 mechanical advantage. The T Series Motor with Parking Brake utilizes the same Geroler, and Spool Valve technologies as the standard Char-Lynn motors. Therefore, in addition to providing dependable load-holding capability, T Series Motor with Parking Brake provides the same smooth, reliable operation, with similar performance, as the T Series Motor.

### Specifications

Geroler Element	11 Displacements
Flow l/min [GPM]	55 [15] Continuous
	75 [20] Intermittent
Speed	Up to 1055 RPM
Pressure bar [PSI]	155 [2250] Cont.
	190 [2750] Inter.
Torque Nm [lb-in]	441 [3905] Cont.
	486 [4300] Inter.

### Features

- Integrated, Compact, Patented Design
- Capability of Combining 4 inventory items into a single assembly (motor, brake, counter-balance valve, brake release line)
- Rear-mounted integrated brake with 6:1 torque advantage
- Access port for manual brake release (for overriding brake in the event of loss of release pressure.)

### Benefits

- Cost-effective Packaged System Solution
- Simplifies ordering and inventory requirements
- Reduces assembly labor
- Design Flexibility
- Wet brake is environmentally protected and provides long life

### Applications

- Truck-Mounted Equipment (boom rotate and winch)
- Conveyors – Positioners – Indexers
- Marine Cranes (boom rotate and winch)
- Fishing Winches
- Recycling and Refuse Equipment
- Vehicle Recovery Winches
- Mining Equipment
- Specialty Utility Vehicles/ Machines
- Forestry Grapples
- Agricultural Equipment
- Railroad Equipment
- Airport Support Vehicles
- Lawn & Turf Equipment
- Anywhere Load-Holding is Needed in a Low-Speed High-Torque Drive System

B-4



Crane and winches



Boom Lift (Swing)



Maintenance Equipment

# T Series with Parking Brake (185-)

## Application Information

### Principle of Operation

The wet brake is a spring-applied / pressure release design. Load-holding is applied by a mechanical spring and released by hydraulic pressure. The spring force holds the brake on when hydraulic pressure is absent.

### Release Pressure

Release pressure is defined as the amount of pressure required to fully release the brake. The brake pressure cavity is common (shared) with the motor case. As a result, maximum release pressure is constrained by the motor case-pressure capability. The T Series Motor with Parking Brake incorporates a shaft seal capable up to 1500 psi (see page B-4-15). However, seal life is reduced at higher case pressure.

### Residual Pressure

Residual pressure is the pressure trapped in the system by restrictions or long return lines.

Residual pressure in the motor case will lower the rated load holding torque of the brake.

Therefore, special attention needs to be given when applying this product. Keep in mind that long return lines create higher pressure that will reduce brake holding torque. In applications with high system pressures, the use of a pressure reducing valve to limit case and release pressure is recommended.

### Holding Torque and Motor Output Torque

Holding torque is based on grade holding requirements for a vehicle or other load holding requirements in the application. System pressure and motor displacement are the factors in determining motor output torque. Motor displacement, measured in cubic centimeters or cubic inches, is the volume of fluid required to make one revolution. Motor output torque is the rotary force and is usually measured in inch pounds, newton meters or foot pounds. Maximum motor torque depends on pressure and motor displacement. Both output shaft size and shaft type can also affect motor torque. The T Series Motor with Parking Brake load holding capacity is factory set to match any limiting factor in each specific motor configuration (e.g. displacement, output shaft, etc).

### Note:

Eaton Corporation does not approve any products for customer applications. It is the sole responsibility of the customer to qualify and verify the correct operation of products in their systems.

### Note:

Special attention should be given to system back pressure. System back pressure directly affects brake release pressure and can cause the brake to release at undesired conditions.

### Note:

The T Series with parking brake is not compatible with water based fluids.

### Typical Applications

#### Winch

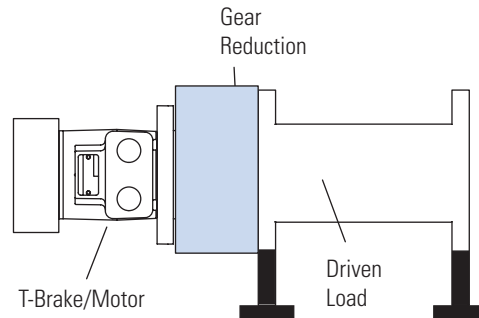

#### Machine Drive

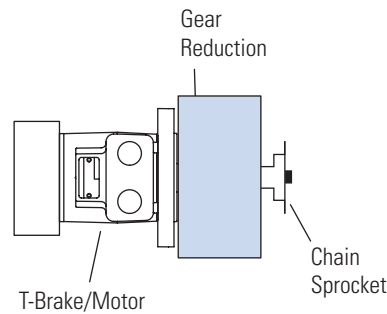

#### Swing Boom

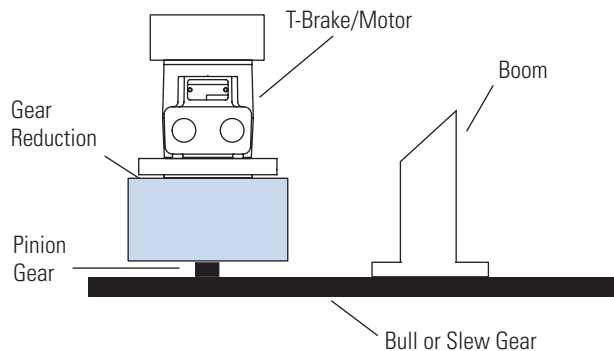

# T Series with Parking Brake (185-)

## Specifications

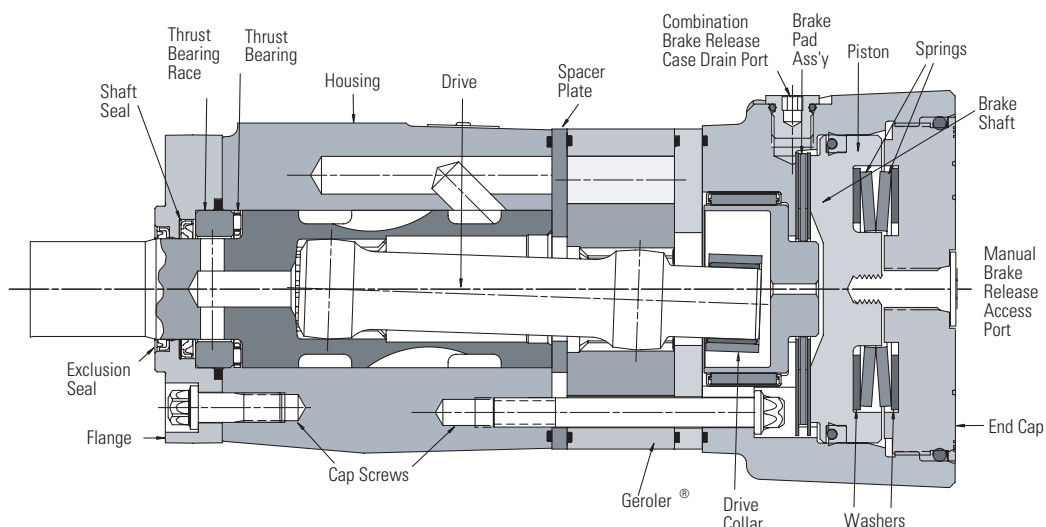

B-4

### SPECIFICATION DATA – T SERIES WITH PARKING BRAKE MOTORS

Displ. cm <sup>3</sup> /r [in <sup>3</sup> /r]		36 [2.2]	49 [3.0]	66 [4.0]	80 [4.9]	102 [6.2]	131 [8.0]	157 [9.6]	195 [11.9]	244 [14.9]	306 [18.7]	370 [22.6]
Max. Speed (RPM) @ Continuous Flow		1021	906	849	694	550	426	355	287	229	183	152
Flow LPM [GPM]	Continuous	38 [10]	45 [12]	57 [15]	57 [15]	57 [15]	57 [15]	57 [15]	57 [15]	57 [15]	57 [15]	57 [15]
	Intermittent	38 [10]	57 [15]	68 [18]	76 [20]	76 [20]	76 [20]	76 [20]	76 [20]	76 [20]	76 [20]	76 [20]
Torque Nm [lb-in]	Continuous	76 [672]	105 [928]	138 [1222]	174 [1541]	219 [1936]	251 [2226]	297 [2628]	359 [3178]	410 [3633]	441 [3905]	430 [3811]
	Intermittent **	93 [824]	118 [1131]	168 [1488]	212 [1872]	264 [2339]	307 [2718]	359 [3178]	437 [3864]	485 [4290]	483 [4275]	486 [4300]
Pressure Δ Bar [Δ PSI]	Continuous *	155 [2250]	155 [2250]	155 [2250]	155 [2250]	155 [2250]	138 [2000]	138 [2000]	138 [2000]	127 [1850]	110 [1600]	90 [1300]
	Intermittent ***	190 [2750]	190 [2750]	190 [2750]	190 [2750]	190 [2750]	172 [2500]	172 [2500]	172 [2500]	155 [2250]	124 [1800]	103 [1500]

### Note:

See page B-4-2 for additional motor specification notes and definitions. The T Series with Parking Brake performance is similar to the standard T Series motor. High speed conditions may reduce performance on T Series with Parking Brake.

### T SERIES BRAKE HOLDING TORQUE SETTINGS:

Shaft Code	Output Shaft Description	[in <sup>3</sup> /r]	2.2	3.0	4.0	4.9	6.2	8.0	9.6	11.9	14.9	18.7	22.6
18	1 Tapered w/key and nut		2,000	2,000	2,000	3,500	3,500	3,500	5,000	5,000	5,000	5,000	5,000
02	1 SAE 6B Splined		2,000	2,000	2,000	3,500	3,500	3,500	5,000	5,000	5,000	5,000	5,000
24	25mm Straight w/key		2,000	2,000	2,000	3,500	3,500	3,500	3,500	3,500	3,500	3,500	3,500
01	1 Straight w/key		2,000	2,000	2,000	3,500	3,500	3,500	3,500	3,500	3,500	3,500	3,500
07	1 Straight w/.31 dia. crosshole		2,000	2,000	2,000	3,500	3,500	3,500	3,500	3,500	3,500	3,500	3,500
08	1 Straight w/.40 dia. crosshole		2,000	2,000	2,000	3,500	3,500	3,500	3,500	3,500	3,500	3,500	3,500
16	7/8 SAE B 13T Splined		2,000	2,000	2,000	2,000	2,000	2,000	2,000	2,000	2,000	2,000	2,000
17	7/8 SAE B Straight w/key		2,000	2,000	2,000	2,000	2,000	2,000	2,000	2,000	2,000	2,000	2,000

**in-lbs** Full Capacity Brake

**in-lbs** Limited Capacity Brake

### Note:

The factory setting values are used for each motor based on motor displacement and shaft type. Average Static torque may vary +/- 14% from rated values.

# T Series with Parking Brake (185-)

## Standard Rotation Viewed from Shaft End

Port A Pressurized — CW  
 Port B Pressurized — CCW

### Dimensions

(Refer to pages B-4-19 thru B-4-22 for shaft and port dimensions.)

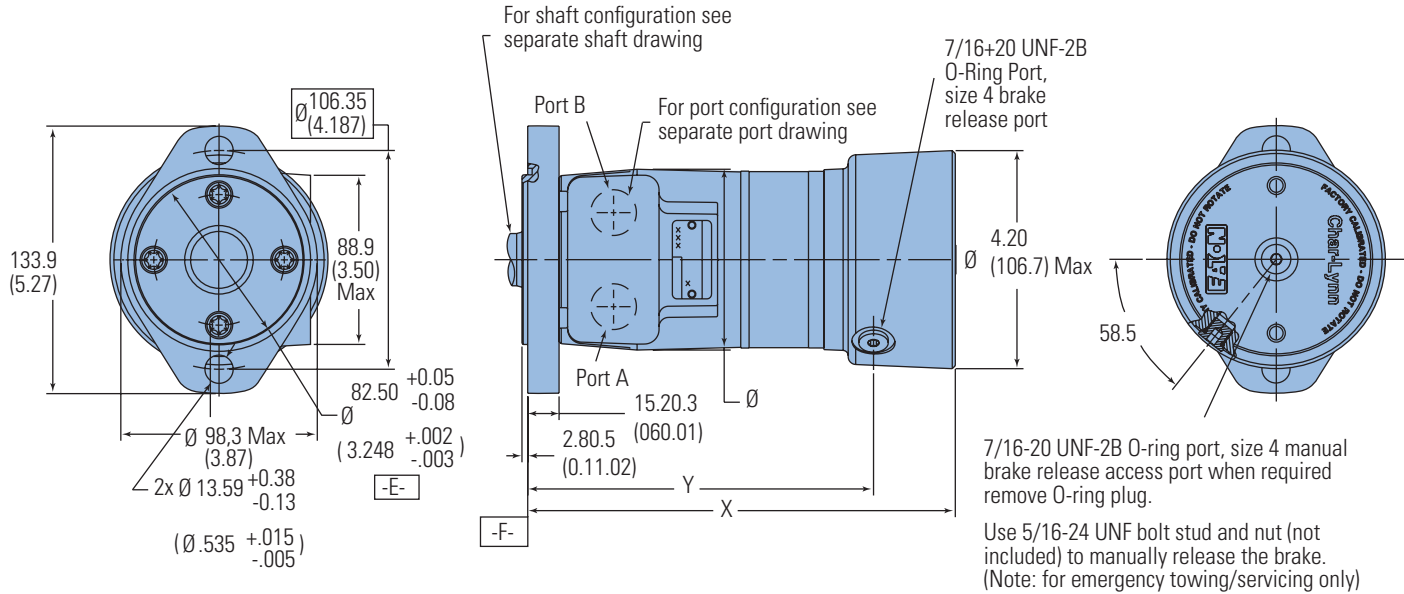

### T-SERIES WITH PARKING BRAKE DIMENSIONS

Displacement cm <sup>3</sup> /r [in <sup>3</sup> /r]	X		Y	
	mm [inch]	mm [inch]	mm [inch]	mm [inch]
36 [2.2]	190.2 [7.49]	143.9±0.9 [5.66±0.3]		
41 [2.5]	190.8 [7.51]	144.5±0.9 [5.69±0.3]		
49 [3.0]	192.5 [7.58]	146.3±0.9 [5.76±0.3]		
5.9 [3.6]	194.3 [7.65]	148.1±0.9 [5.83±0.3]		
65 [4.0]	195.6 [7.70]	149.3±0.9 [5.88±0.3]		
80 [4.9]	198.4 [7.81]	152.0±0.9 [5.98±0.3]		
102 [6.2]	202.2 [7.96]	155.9±0.9 [6.14±0.3]		
131 [8.0]	207.5 [8.17]	161.3±0.9 [6.35±0.3]		
158 [9.6]	212.6 [8.37]	166.2±0.9 [6.54±0.3]		
195 [11.9]	219.2 [8.63]	172.9±0.9 [6.81±0.3]		
244 [14.9]	228.3 [8.99]	181.9±0.9 [7.16±0.3]		
306 [18.7]	239.5 [9.43]	193.3±0.9 [7.61±0.3]		
370 [22.6]	251.2 [9.89]	205.0±0.9 [8.07±0.3]		

### Note:

#### Standard Rotation

When facing shaft end of motor shaft to rotate clockwise when port "A" is pressurized, counterclockwise when port "B" is pressurized

#### Reverse Rotation

When facing shaft end of motor shaft will rotate clockwise when port "B" is pressurized, counterclockwise when port "A" is pressurized

# T Series with Parking Brake (185-)

## Brake Release and Motor Case Pressure

The T Series Motor with Parking Brake is durable and has long life as long as the recommended case pressure is not exceeded. Allowable case pressure is highest at low shaft speeds. Motor life will be shortened if case pressure exceeds recommended ratings (acceptability may vary with application).

Refer to the Case Pressure/ Shaft Seal chart below. This chart is based on case pressure and motor shaft speed. A minimum release pressure of 17 Bar [250 PSI] must be maintained to fully release the brake.

B-4

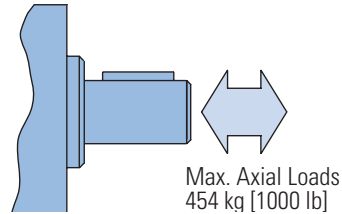
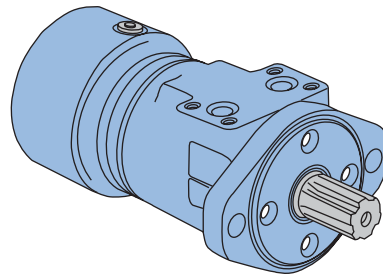

$$P_C \approx 6 DP + P_2$$

$P_C$  = Case Pressure  
 $P_1$  = Inlet Line Pressure  
 $P_2$  = Back Pressure  
 $DP = P_1 - P_2$

### Case Pressure/Shaft Seal

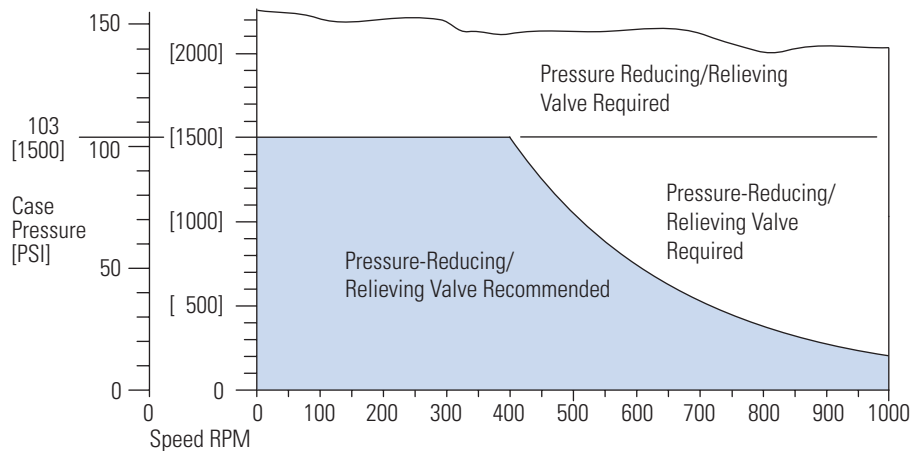

# T Series with Parking Brake (185-)

Product Numbers

Use digit prefix —  
185 plus four digit number  
from charts for complete  
product number —  
Example 185-2068.

**Orders will not be accepted  
without three digit prefix.**

## Standard Valving

MOUNTING	SHAFT	PORT SIZE	DISPL. cm <sup>3</sup> /r [in <sup>3</sup> /r] / PRODUCT NUMBER									
			3.0	4.0	4.9	6.2	8.0	9.6	11.9	14.9	18.7	22.6
2-Bolt	1 Keyed	7/8-14 O-Ring Manifold	185-2000 185-2010	2001 2011	2002 2012	2003 2013	2004 2014	2005 2015	2006 2016	2007 2017	2008 2018	2009 2019
		6B Splined	7/8-14 O-Ring Manifold	185-2020 185-2030	2021 2031	2022 2032	2023 2033	2024 2034	2025 2035	2026 2036	2027 2037	2028 2038
	13T Splined 16/32 pitch	7/8-14 O-Ring Manifold	185-2040 185-2050	2041 2051	2042 2052	2043 2053	2044 2054	2045 2055	2046 2056	2047 2057	2048 2058	2049 2059
4-Bolt	1 Keyed	7/8-14 O-Ring Manifold	185-2060 185-2070	2061 2071	2062 2072	2063 2073	2064 2074	2065 2075	2066 2076	2067 2077	2068 2078	2069 2079
		6B Splined	7/8-14 O-Ring Manifold	185-2080 185-2090	2081 2091	2082 2092	2083 2093	2084 2094	2085 2095	2086 2096	2087 2097	2088 2098
	13T Splined 16/32 pitch	7/8-14 O-Ring Manifold	185-2100 185-2110	2101 2111	2102 2112	2103 2113	2104 2114	2105 2115	2106 2116	2107 2117	2108 2118	2109 2119
2-Bolt SAE B	1 Keyed	7/8-14 O-Ring Manifold	185-2120 185-2130	2121 2131	2122 2132	2123 2133	2124 2134	2125 2135	2126 2136	2127 2137	2128 2138	2129 2139
		6B Splined	7/8-14 O-Ring Manifold	185-2140 185-2150	2141 2151	2142 2152	2143 2153	2144 2154	2145 2155	2146 2156	2147 2157	2148 2158
	13T Splined 16/32 pitch	7/8-14 O-Ring Manifold	185-2160 185-2170	2161 2171	2162 2172	2163 2173	2164 2174	2165 2175	2166 2176	2167 2177	2168 2178	2169 2179

## Low Speed Valving

MOUNTING	SHAFT	PORT SIZE	DISPL. cm <sup>3</sup> /r [in <sup>3</sup> /r] / PRODUCT NUMBER									
			3.0	4.0	4.9	6.2	8.0	9.6	11.9	14.9	18.7	22.6
2-Bolt	1 Keyed	7/8-14 O-Ring Manifold	185-2180 185-2190	2181 2191	2182 2192	2183 2193	2184 2194	2185 2195	2186 2196	2187 2197	2188 2198	2189 2199
		6B Splined	7/8-14 O-Ring Manifold	185-2200 185-2210	2201 2211	2202 2212	2203 2213	2204 2214	2205 2215	2206 2216	2207 2217	2208 2218
	13T Splined 16/32 pitch	7/8-14 O-Ring Manifold	185-2220 185-2230	2221 2231	2222 2232	2223 2233	2224 2234	2225 2235	2226 2236	2227 2237	2228 2238	2229 2239
4-Bolt	1 Keyed	7/8-14 O-Ring Manifold	185-2240 185-2250	2241 2251	2242 2252	2243 2253	2244 2254	2245 2255	2246 2256	2247 2257	2248 2258	2249 2259
		6B Splined	7/8-14 O-Ring Manifold	185-2260 185-2270	2261 2271	2262 2272	2263 2273	2264 2274	2265 2275	2266 2276	2267 2277	2268 2278
	13T Splined 16/32 pitch	7/8-14 O-Ring Manifold	185-2280 185-2290	2281 2291	2282 2292	2283 2293	2284 2294	2285 2295	2286 2296	2287 2297	2288 2298	2289 2299
2-Bolt SAE B	1 Keyed	7/8-14 O-Ring Manifold	185-2300 185-2310	2301 2311	2302 2312	2303 2313	2304 2314	2305 2315	2306 2316	2307 2317	2308 2318	2309 2319
		6B Splined	7/8-14 O-Ring Manifold	185-2320 185-2330	2321 2331	2322 2332	2323 2333	2324 2334	2325 2335	2326 2336	2327 2337	2328 2338
	13T Splined 16/32 pitch	7/8-14 O-Ring Manifold	185-2340 185-2350	2341 2351	2342 2352	2343 2353	2344 2354	2345 2355	2346 2356	2347 2357	2348 2358	2349 2359

185-2357

Motors with the low speed valving option enable very smooth low speed operation while maintaining high torque.

Designed to run continuously at up to 200 RPM at standard rated pressures and reduced

flows, this option provides smooth operation at low speeds. Furthermore, they resist slippage and have more momentary load holding ability than the standard motors.

**Motors with this valving are not intended for low pressure applications (A minimum of 300 psi delta must be maintained between A port pressure and case pressure).**

Shaft side / radial load ratings are not affected by

this valving.

For a T Series motor with parking brake configuration not shown in the charts above use the model code system on page B-4-17 to specify the product in detail.

# T Series with Parking Brake (185-)

Model Code

The following 30-digit coding system has been developed to identify all of the configuration options for the T Series Motor with Parking Brake. Use this model code to specify a motor with the desired features. All 30-digits of the code must be present when ordering. You may want to photocopy the matrix below to ensure that each number is entered in the correct box.

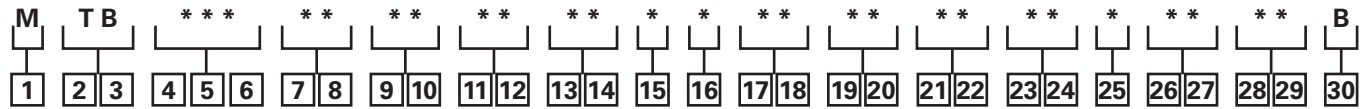

## 1 Product

M – Motor

## 2, 3 Series

T B – T Series Motor with Parking Brake

## 4, 5, 6 Displacement cm<sup>3</sup>/r [in<sup>3</sup>/r]

022 – 36 [2.2]  
030 – 49 [3.0]  
040 – 66 [4.0]  
049 – 80 [4.9]  
062 – 102 [6.2]  
080 – 131 [8.0]  
096 – 157 [9.6]  
119 – 195 [11.9]  
149 – 244 [14.9]  
187 – 306 [18.7]  
226 – 370 [22.6]

## 7, 8 Mounting Type

AA – 2 Bolt (Standard)  
82,5 [3.248] Dia. and 3,05  
[.120] pilot, 13,59 [.535]  
Dia. Mounting Holes 106,35  
[4.187] Dia. B.C.

BA – 4 Bolt (Standard)  
44,40 [1.748] Dia. x 3,05  
[.120] pilot, .375-16 UNC-2B  
Mounting Holes 82,55  
[3.250] Dia. B.C.

CA – 2 Bolt (Standard) 82,50  
[3.248] Dia. x 6,10 [.240] pilot,  
10,41 [.410] Dia. Mounting  
Holes 106,35 [4.187] Dia. B.C.  
(SAE A)

DA – 2 Bolt (Std.) 101,60  
[4.000] Dia. x 6.10 [.240] pilot,  
14,35 [.565] Dia. Mounting  
Holes 146,05 [5.750] Dia. B.C.  
(SAE B)

EA – 4 Bolt Magneto 82,50  
[3.248] Dia. x 3,05 [.120] Pilot,  
13,59 [.535] Dia. Mounting  
Holes 106,35 [4.187] Dia. B.C.

FA – 4 Bolt (Standard)  
44,40 [1.748] Dia. x 3,05  
[.120] pilot, M10 x 1.5-6H  
Mounting Holes on 82,55  
[3.250] Dia. B.C.

## 9, 10 Output Shaft Description

01 – 25,4 [1.00] Dia. Straight,  
Woodruff Key, .250-20  
UNC-2B Hole in Shaft End

02 – 25,4 [1.00] Dia. SAE 6B  
Spline, .25-20 UNC-2B Hole  
in Shaft End

16 – SAE 13 Tooth Spline,  
16/32 Pitch, 21,74 (.856) Dia.  
(SAE B)

18 – 25,4 [1.00] Dia. Tapered,  
Woodruff Key  
and Nut, 34,92 [1.375]  
Taper Length

24 – 25,00 [.984] Dia.  
Straight, 8.0 [.315] Key, MB  
x 1.25-6H Hole in Shaft End

## 11, 12 Port Type

AA – .875-14 UNF-2B SAE  
O-Ring Ports

AB – .500-14 NPTF Dryseal  
Pipe Thread Ports

AC – Manifold (.3125-18  
UNC-2B Mounting Holes)

AD – Manifold Ports (MB x  
1.25-6H Mounting Holes)

AF - G 1/2 BSP Straight  
Thread Ports

## 13, 14 Case Flow Options

00 – None Specified

02 – G 1/4 BSP Straight THD  
Port (End Cap)

03 – Manifold Case Drain

04 – .4375-20 UNF-2B SAE  
O-RING PORT (SIDE OF  
HOUSING)

05 – .3125-24 UNF-2B SAE  
O-RING PORT (MOUNTING  
FLANGE)

11 - Internal Check Valves

## 15 Geroler® Options

A – Standard

B – Free Running

## 16 Shaft Options

0 – None

N – Electroless Nickel Plated

## 17, 18 Seal Options

00 – Standard Seals

02 – Seal Guard

03 – Viton Seals

04 – Viton Shaft Seal

07 – High Pressure Shaft Seal

11 – High pressure shaft  
seal, slinger seal

19 – Extreme duty seal  
guard

## 19, 20 Speed Sensor Options

00 – None

AA – 12 mm Digital Speed  
Pickup (15 Pulse) without  
Lead Wire

## 21, 22 Valve Options

0 – None

## 23, 24 Special Features (Hardware)

00 – None Specified

AB – Low Speed Valving

## 25 Special Assembly Instructions

0 – None

2 – Flange Rotation 90°

## 26, 27 Paint/Packaging Options

00 – No Paint

AA – Low Gloss Black Primer

## 28, 29 Customer ID/ Nameplate Options

0 – None Specified

## 30 Design Code

B – Two (2)

Feature in **bold** are preferred and allow for shorter lead time.

B-4

# Case Pressure and Case Drain — H, S, and T Series

Char-Lynn H Series, S Series and T Series motors are durable and have long life as long as the recommended case pressure is not exceeded. Allowable case pressure is highest at low shaft speeds. Consequently, motor life will be shortened if case pressure exceeds these ratings (acceptability may vary with application). Determine if an external case drain is required

from the case pressure seal limitation chart below — chart based on case pressure and shaft speed. If a case drain line is needed, connect drain line to assure that the motor will always remain full of fluid. A pressure restriction should be added to the case drain line, during which a motor case pressure of 3,5 Bar [50 PSI] is maintained.

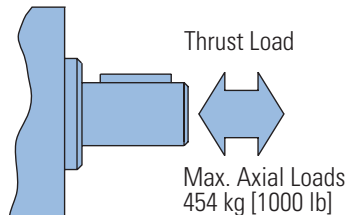

$$P_C \approx 6 \Delta P + P_2$$

$P_C$  = Case Pressure  
 $P_1$  = Inlet Line Pressure  
 $P_2$  = Back Pressure  
 $\Delta P = P_1 - P_2$

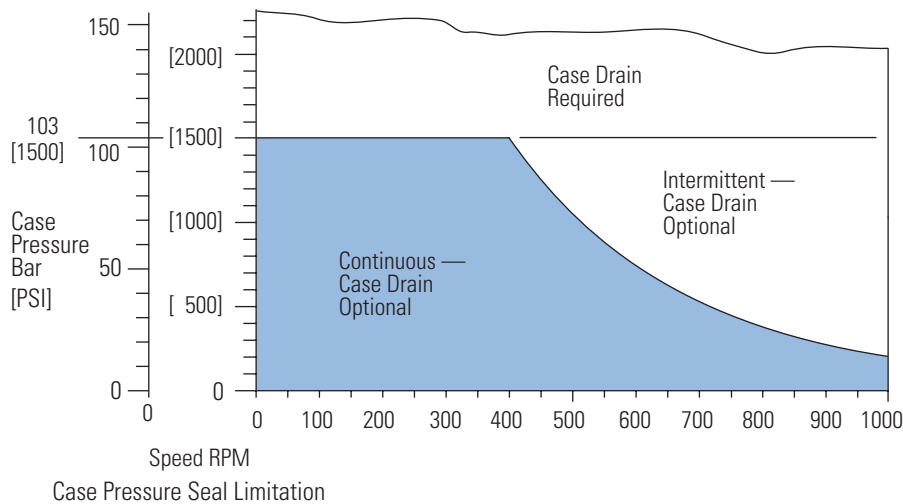
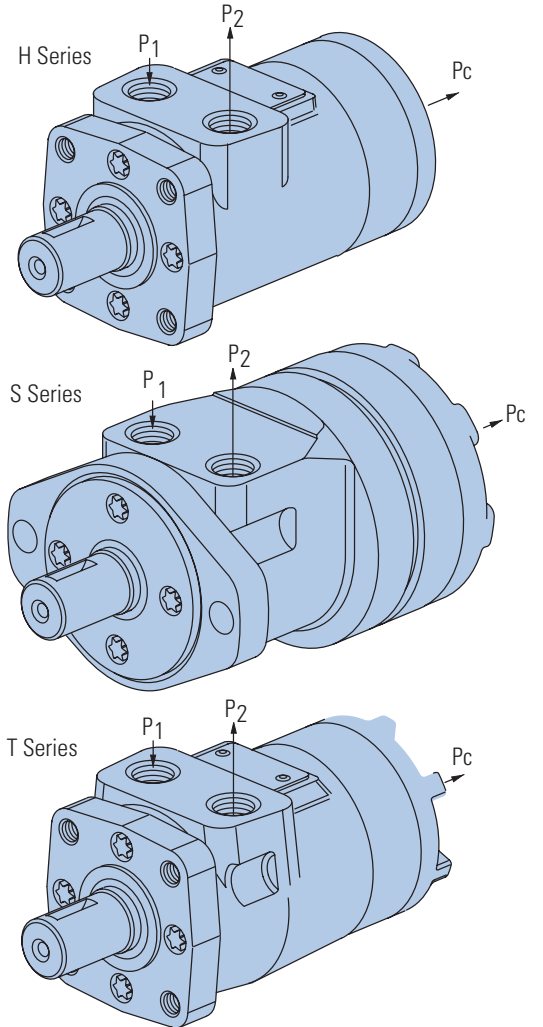



# H, S and T Series (101-, 103-, 158-, 185-)

## Side Load Capacity

The hydrodynamic bearing has infinite life when shaft load ratings are not exceeded. Hence, the shaft side load capacity is more than adequate to handle most externally applied loads (such as belts, chains, etc.), providing the motor to shaft size is applied within its torque rating.

Allowable side load chart, shaft load location drawing and load curves (below) are based on the side / radial loads being applied to shaft at locations A, B, and C, to

determine the shaft side load capacity at locations other than those shown use the formula (shown below).

For more information about shaft side loads on Char-Lynn motors contact your Eaton representative.

### Note:

When the speed sensor option is used, side load ratings are reduced 25%.

RPM	ALLOWABLE SHAFT SIDE LOAD – KG [LB]		
	A	B	C
900	154 [ 339]	136 [ 300]	118 [ 261]
625	205 [ 452]	181 [ 400]	158 [ 348]
500	256 [ 565]	227 [ 500]	197 [ 435]
400	307 [ 678]	272 [ 600]	237 [ 522]
300	410 [ 904]	363 [ 800]	316 [ 696]
200	718 [1582]	635 [1400]	552 [1216]

$$\text{Sideload P kg} = \frac{900}{N} \left( \frac{16800}{L + 96,3} \right) \text{ for 200-900 RPM}$$

$$\text{Sideload P [lb]} = \frac{900}{N} \left( \frac{1460}{L + [3.79]} \right) \text{ for 200-900 RPM}$$

Where N = Shaft Speed (RPM)

L = Distance from Mounting Surface

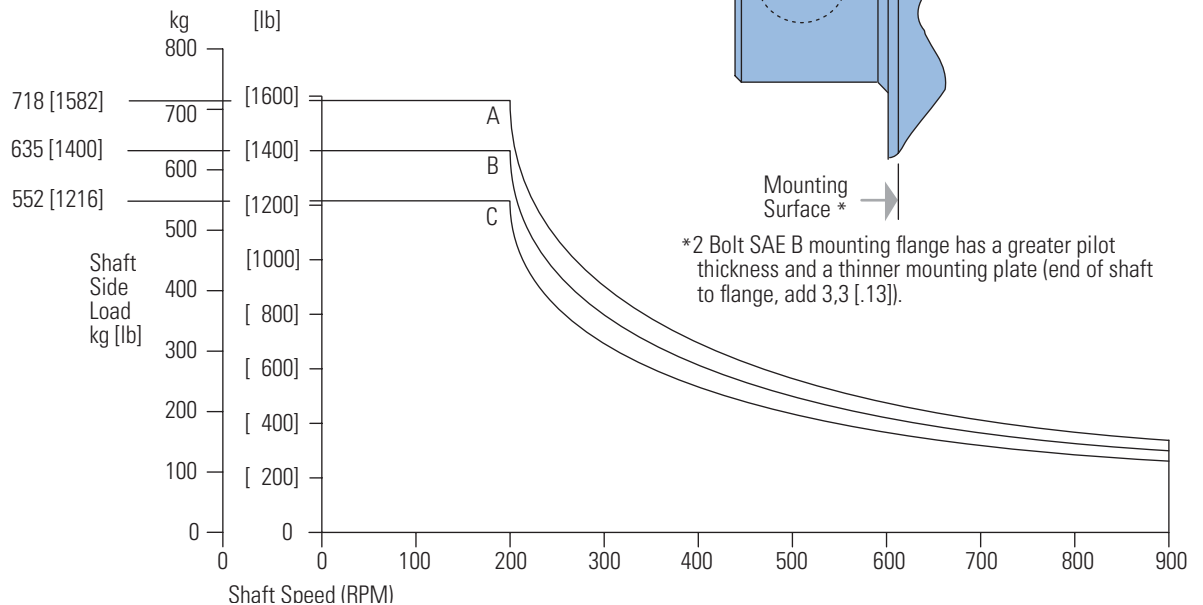

# H, S and T Series (101, 103- 158, 185)

## Dimensions

### Shafts

#### Shaft Size Motor Torque Combination Limit Guide

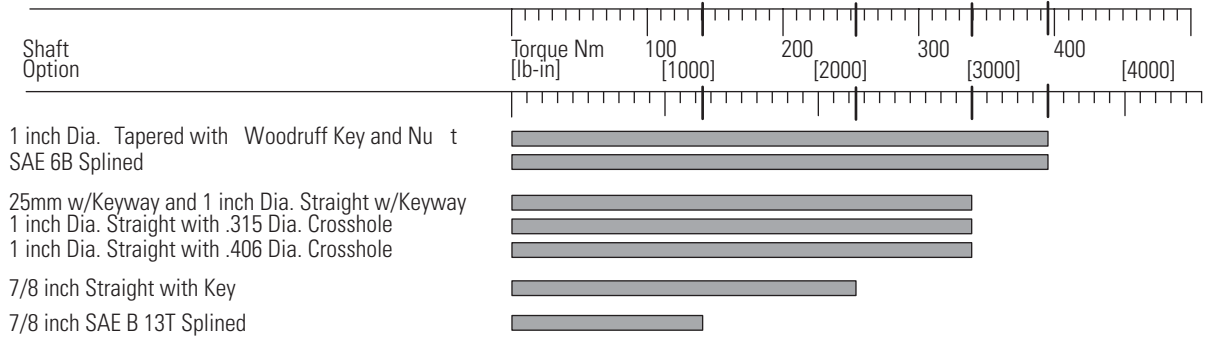

#### 1 in. Dia. Straight with Woodruff Key

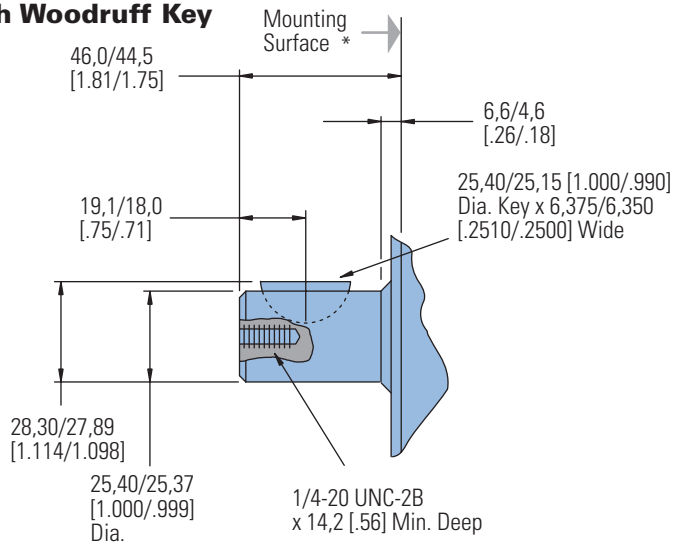

#### SAE 6B Splined Shaft

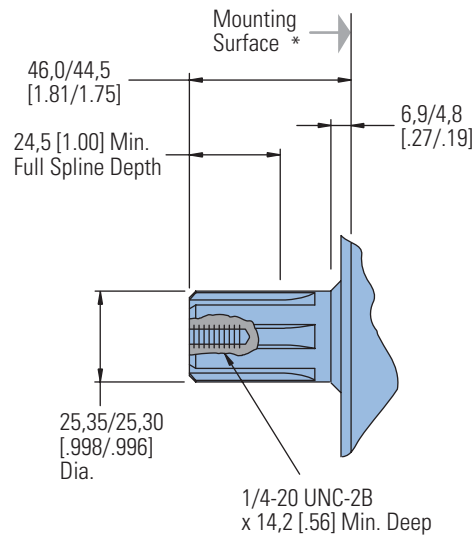

#### 1 in. Dia. Straight Shaft with .315 Dia. Crosshole

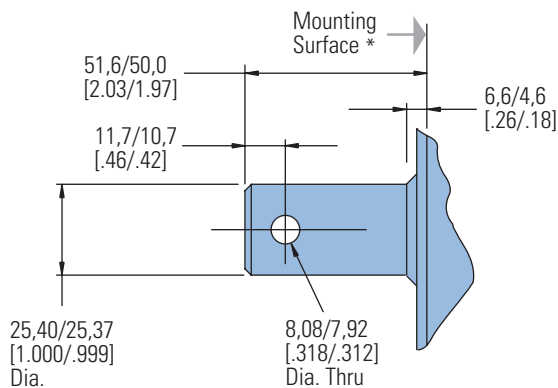

#### 1 in. Dia. Straight Shaft with .406 Dia. Crosshole

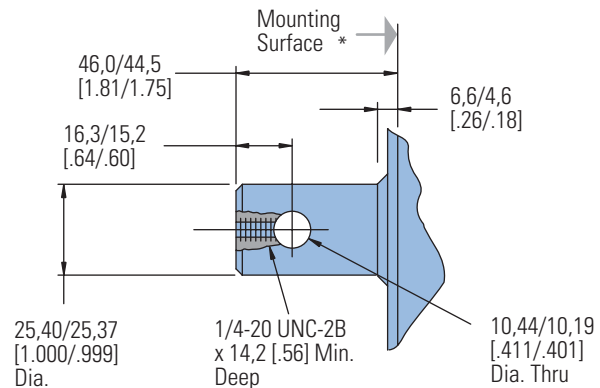

\* 2 Bolt SAE B mounting flange has a greater pilot thickness and a thinner mounting plate (end of shaft to flange, add 3,3 [.13]).

# H, S and T Series (101-, 103- 158-, 185-)

## Dimensions

### Shafts

#### 1 in. Dia. Tapered Shaft with Woodruff Key and Nut

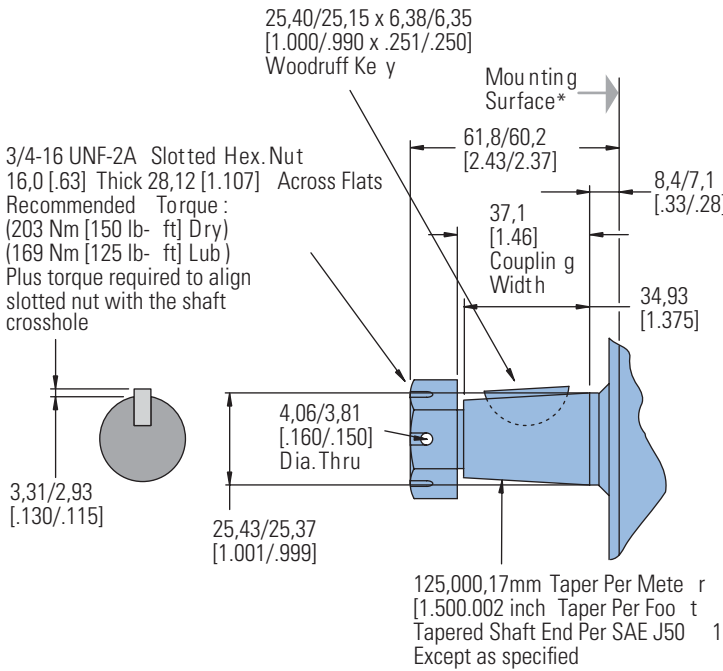

#### 25mm Dia. Straight Shaft with 8mm Keyway

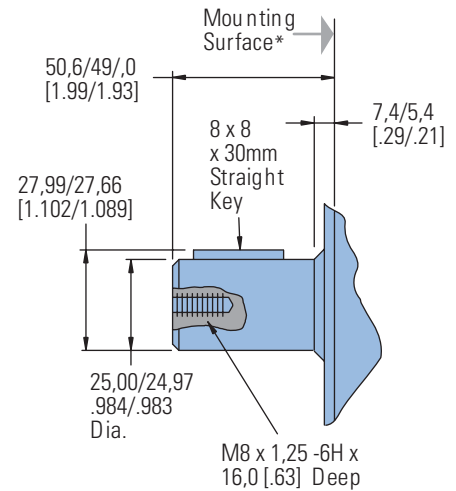

#### 7/8 in. Dia. Straight Shaft with Key

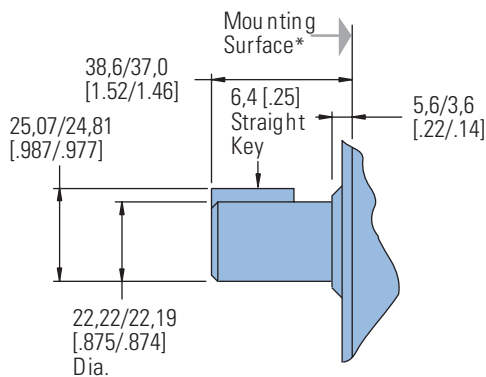

#### 7/8 in. Dia. SAE B Shaft 13T Splined

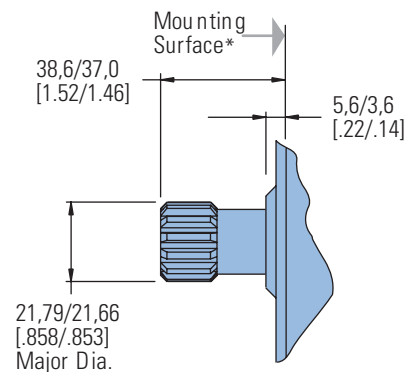

\* 2 Bolt SAE B mounting flange has a greater pilot thickness and a thinner mounting plate (end of shaft to flange, add 3,3 [.13]).

# H, S and T Series (101-, 103- 158-, 185-)

Mounting Options

**Note:**

Mounting Surface Flatness Requirement is ,13 mm [.005 inch] Max.

## 4 Bolt Magneto

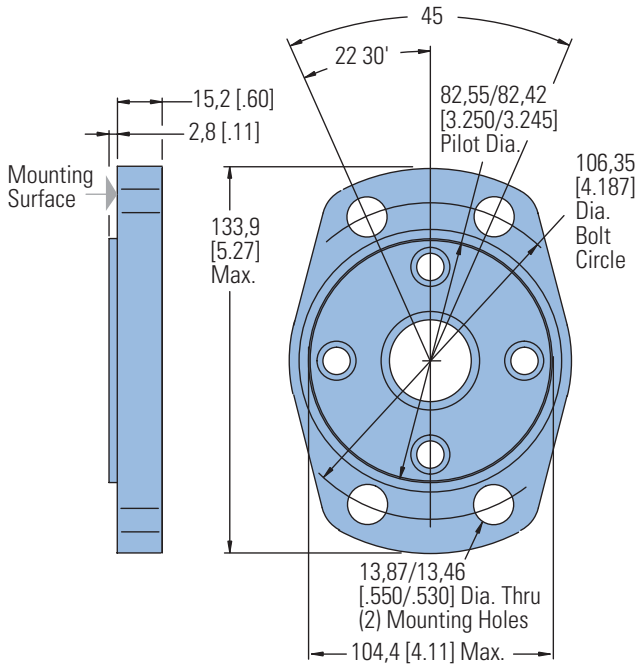

## Base Block Mounting Kits

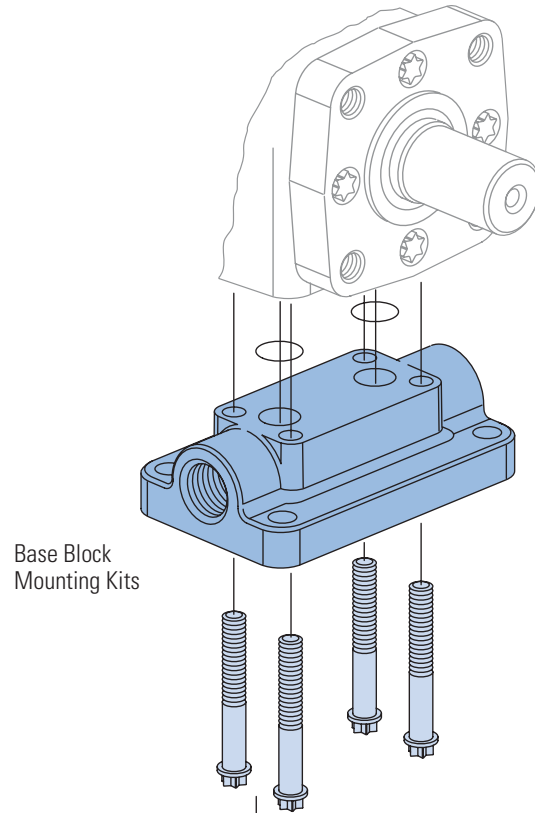

## 2 Bolt SAE B

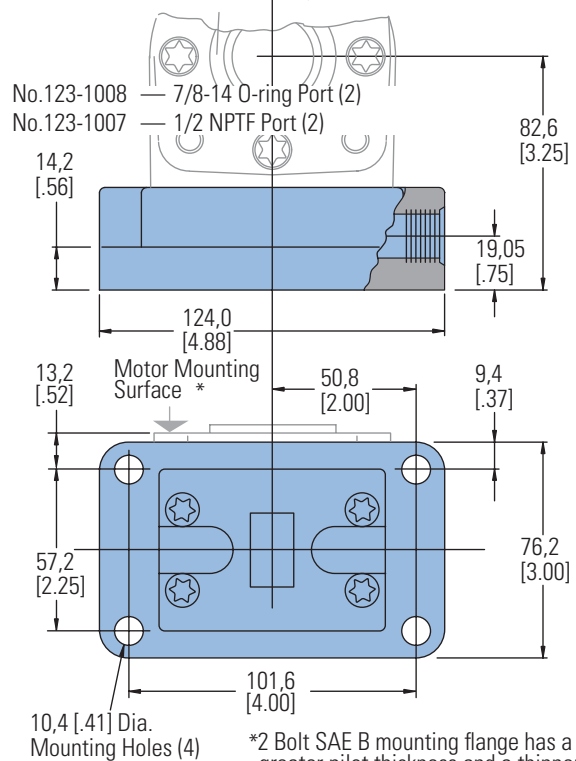
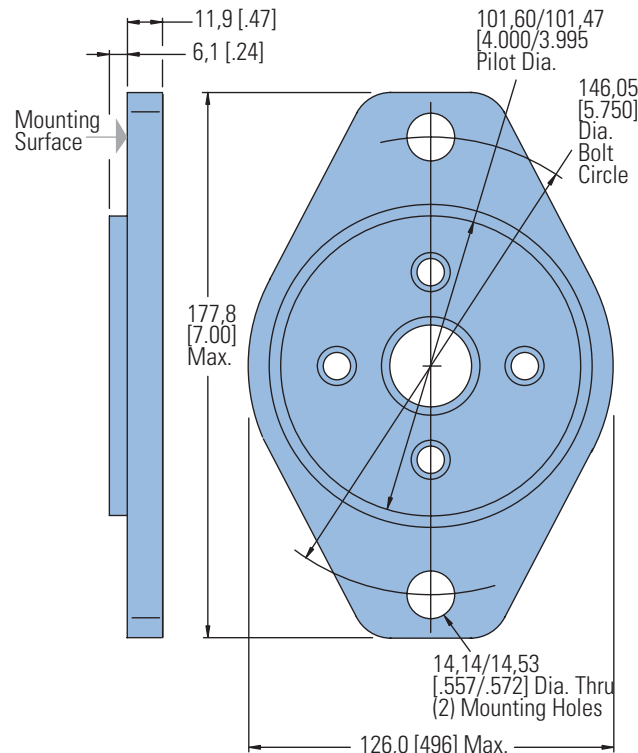

# H, S and T Series (101-, 103-, 158-, 185-)

## Dimensions

### Ports

### Ports

End Ports — H Series only  
G 1/2 (BSP) (2)  
or 3/4-16 O-Ring (2)

### Standard Rotation Viewed from Drive End

Port A Pressurized — CW  
Port B Pressurized — CCW

### Note:

End ported motor pressure is derated. Reference page B-2-2 for ratings.

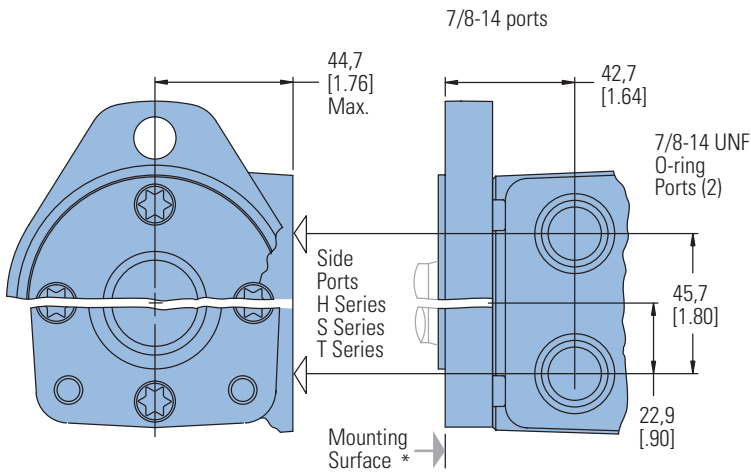

End Ports (H Series only)

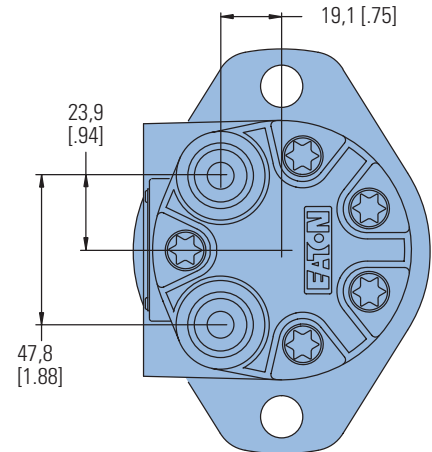

Use of Teflon Tape Sealant/Lubricant (with 1/2 14 NPTF Port Connectors only).

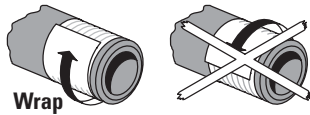

When using fittings with Teflon tape, be careful when taping and tightening. Over tightening or improperly taped fittings can cause damage to housing or leakage.

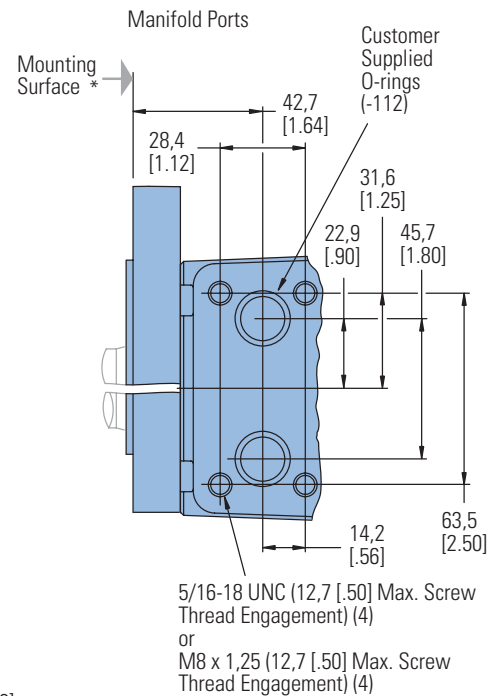
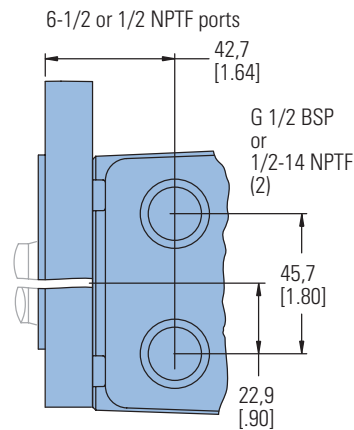

### Use the following procedures:

- Wrap approx. 1 1/2 Turns of 13 mm [1/2 in.] wide Teflon Tape around fitting threads — start tape 2 threads up from end of fitting.
- Tighten threads to a Maximum of 34 Nm [25 lb-ft]. — Do Not Tighten Further —
- If fittings leak when tightened to maximum torque, either retape, reseal, or replace fittings.

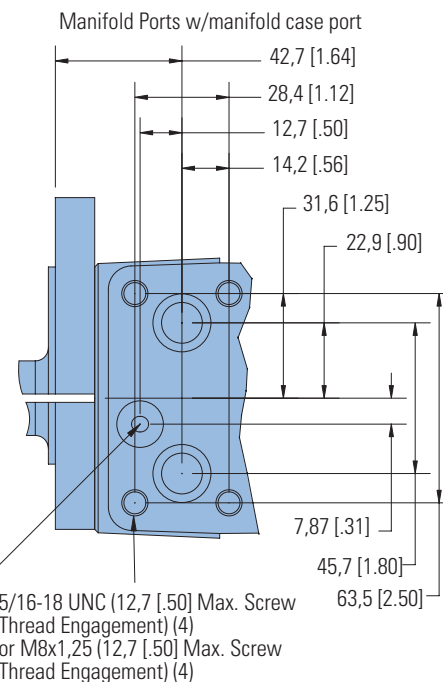

### Note:

End ported motor option is derated to 1400 continuous, 1700 psi intermittent.

\*2 Bolt SAE B mounting flange has a greater pilot thickness and a thinner mounting plate.

B-2

B-3

B-4

# Notes

# W Series (162-)

## Highlights

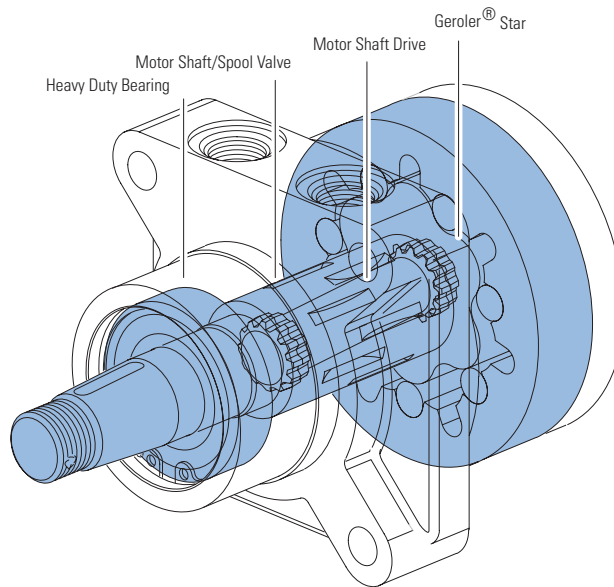

### Features:

- Heavy duty bearing
- Wheel drive interface
- Three-pressure zone design (ability to reduce case pressure)
- Variety of displacements, shafts, mounts and special options
- Special options to meet customer needs

### Benefits:

- High side-load capacity
- High shock load capability
- Wheel mount interface
- Compact powerful package
- High efficiency
- Smooth low-speed operation
- Extended leak-free performance

### Applications:

- Scissors lifts
- Boom lifts
- Mid-size ZTR mowers
- Turf equipment
- Greens mowers
- Sand trap rakes
- Railroad maintenance equipment
- Industrial sweepers and floor polishers
- Skid steer attachments
- Many more

### Description

Char-Lynn W Series motors with the Geroler displacement element offer the same low friction and long-life advantages as the S and T Series.

The W Series features the simplicity of Eaton's proven spool valve and a Geroler element that provides superior drive life and smooth performance. In addition, this motor has a rugged housing with an extra large capacity side load bearing.

### W Series Motors

Geroler Element	7 Displacements
Flow l/min [GPM]	68 [18] Continuous*** 76 [20] Intermittent**
Speed	288 RPM
Pressure bar [PSI]	165 [2400] Cont.*** 179 [2600] Inter.**
Torque Nm [lb-in]	410 [3624] Cont.*** 562 [4970] Inter.**

\*\*\* Continuous— (Cont.) Continuous rating, motor may be run continuously at these ratings.

\*\* Intermittent— (Inter.) Intermittent operation, 10% of every minute.



Scissor Lift



Sweeper



Trencher



Boom Lift

# W Series (162-)

## Specifications

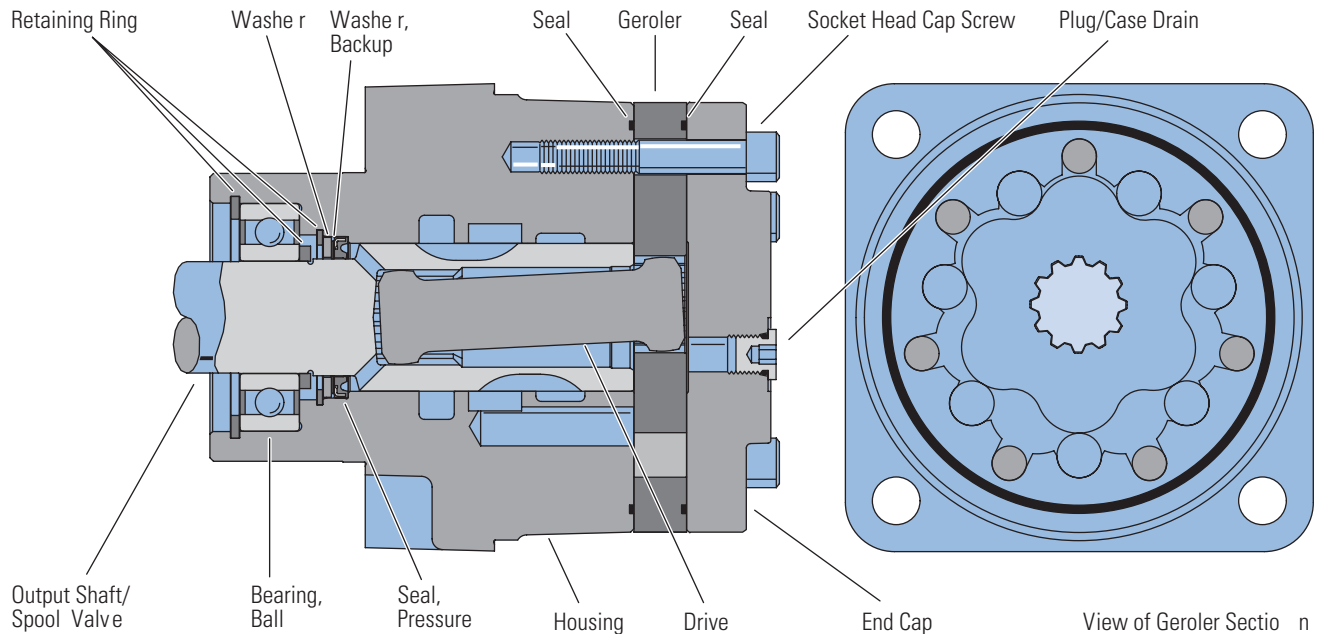

### SPECIFICATION DATA – W SERIES MOTORS

Displ. cm <sup>3</sup> /r [in <sup>3</sup> /r]		80 [4.9]	126 [7.7]	154 [9.4]	195 [11.9]	251 [15.3]	303 [18.5]	374 [22.8]
Max. Speed (RPM)		267	288	214	200	200	200	200
Flow l/min [GPM]	Continuous	23 [6]	30 [8]	34 [9]	38 [10]	53 [14]	62 [16.5]	68 [18]
	Intermittent	23 [6]	30 [8]	34 [9]	38 [10]	53 [14]	62 [16.5]	76 [20]
Theo. Torque Nm [lb-in]	Continuous	176 [1555]	279 [2470]	318 [2813]	318 [2816]	375 [3319]	387 [3429]	410 [3624]
	Intermittent	189 [1676]	298 [2640]	373 [3301]	439 [3882]	548 [4849]	539 [4769]	562 [4970]
Pressure Δbar [ΔPSI]	Continuous	165 [2400]	165 [2400]	152 [2200]	124 [1800]	110 [1600]	97 [1400]	83 [1200]
	Intermittent	179 [2600]	179 [2600]	179 [2600]	179 [2600]	165 [2400]	138 [2000]	124 [1800]

#### Note:

To assure best motor life, run motor for approximately one hour at 30% of rated pressure before application to full load. Be sure motor is filled with fluid prior to any load applications.

#### Maximum Inlet Pressure:

179 bar [2600 PSI]  
Do Not Exceed Δ Pressure Rating (for displacement size see chart above).

#### Return Pressure (Back-Pressure):

Do not exceed Δ pressure rating (see chart above). Case drain required.

#### Note:

Optional version can be used without case drain.

#### Case Pressure:

Minimum – No Pressure  
Maximum – 103 bar [1500 PSI] without case drain.

#### Note:

The case must be flooded when the motor is operating.

#### Δ Pressure:

The true Δ bar [Δ PSI] between inlet port and return port

#### Continuous Rating:

Motor may be run continuously at these ratings

#### Intermittent Operation:

10% of every minute

#### Recommended Fluids:

Premium quality, anti-wear type hydraulic oil with a viscosity of not less than 70 SUS at operating temperature.

#### Recommended System Operating Temp.:

-34°C to 82°C [-30°F to 180°F]

#### Recommended Filtration:

per ISO Cleanliness Code, level 20/18/13





# W Series (162-)

## Performance Data

Motors run with high efficiency in all areas designated with a number for torque and speed. For best motor life select a motor to run with a torque and speed range shown in the light shaded area.

Performance data is typical at 120 SUS. Actual data may vary slightly from motor to motor in production.

 Continuous  
 Intermittent

### 80 cm<sup>3</sup>/r [4.9 in<sup>3</sup>/r] Δ Pressure bar [PSI]

		Continuous											
		[400]	[600]	[800]	[1000]	[1200]	[1400]	[1600]	[1800]	[2000]	[2200]	[2400]	[2600]
		28	41	55	69	83	97	110	124	138	152	165	179
Flow /min [GPM]	[2]	[204]	[337]	[474]	[612]	[748]	[883]	[1019]	[1149]	[1281]	[1412]	[1540]	[1610]
	7.6	23	38	54	69	85	100	115	130	145	160	174	182
	[4]	[223]	[357]	[489]	[627]	[769]	[902]	[1035]	[1169]	[1295]	[1424]	[1555]	[1676]
	15.1	25	40	55	71	87	102	117	132	146	161	176	189
[6]	[255]	[342]	[477]	[612]	[749]	[879]	[1014]	[1154]	[1286]	[1408]	[1533]	[1648]	
22.7	29	39	54	69	85	99	115	130	145	159	173	186	
		267	265	262	258	257	252	248	241	235	229	219	206

### 126 cm<sup>3</sup>/r [7.7 in<sup>3</sup>/r] Δ Pressure bar [PSI]

		Continuous											
		[400]	[600]	[800]	[1000]	[1200]	[1400]	[1600]	[1800]	[2000]	[2200]	[2400]	[2600]
		28	41	55	69	83	97	110	124	138	152	165	179
Flow /min [GPM]	[2]	[390]	[605]	[817]	[1032]	[1248]	[1448]	[1656]	[1871]	[2069]	[2243]	[2414]	[2513]
	7.6	44	68	92	117	141	164	187	211	234	253	273	284
	[4]	[382]	[605]	[817]	[1036]	[1252]	[1463]	[1694]	[1908]	[2113]	[2306]	[2470]	[2640]
	15.1	43	68	92	117	141	165	191	216	239	261	279	298
[6]	[367]	[587]	[802]	[1017]	[1236]	[1444]	[1668]	[1882]	[2091]	[2284]	[2459]	[2637]	
22.7	41	66	91	115	140	163	188	213	236	258	278	298	
	172	167	164	161	156	152	147	141	134	130	120	103	
[8]	[346]	[561]	[769]	[981]	[1203]	[1419]	[1634]	[1849]	[2039]	[2217]	[2432]	[2633]	
30.3	39	63	87	111	136	160	185	209	230	250	275	297	
	228	225	220	216	213	208	201	195	188	174	163	149	

### 154 cm<sup>3</sup>/r [9.4 in<sup>3</sup>/r] Δ Pressure bar [PSI]

		Continuous											
		[400]	[600]	[800]	[1000]	[1200]	[1400]	[1600]	[1800]	[2000]	[2200]	[2400]	[2600]
		28	41	55	69	83	97	110	124	138	152	165	179
Flow /min [GPM]	[2]	[450]	[723]	[989]	[1249]	[1512]	[1769]	[2021]	[2269]	[2502]	[2714]	[2904]	[3019]
	7.6	51	82	112	141	171	200	228	256	283	307	329	341
	[4]	[470]	[737]	[1009]	[1276]	[1540]	[1802]	[2064]	[2323]	[2570]	[2813]	[3019]	[3242]
	15.1	53	83	114	144	174	204	233	262	290	318	341	366
[6]	[435]	[715]	[984]	[1252]	[1513]	[1787]	[2020]	[2274]	[2521]	[2812]	[3042]	[3301]	
22.7	49	81	111	141	171	202	228	257	285	318	344	373	
	143	140	138	137	134	131	128	124	117	112	103	91	
[8]	[407]	[677]	[945]	[1214]	[1477]	[1740]	[2005]	[2260]	[2503]	[2735]	[2964]	[3206]	
30.3	46	76	107	137	167	197	227	255	283	309	335	362	
	190	188	186	184	182	179	176	171	166	158	148	137	
[9]	[380]	[648]	[914]	[1183]	[1452]	[1714]	[1981]	[2243]	[2499]	[2733]	[2964]	[3195]	
34	43	73	103	134	164	194	224	253	282	309	335	361	
	214	212	210	207	206	202	200	196	191	182	173	162	

### 195 cm<sup>3</sup>/r [11.9 in<sup>3</sup>/r] Δ Pressure bar [PSI]

		Continuous											
		[400]	[600]	[800]	[1000]	[1200]	[1400]	[1600]	[1800]	[2000]	[2200]	[2400]	[2600]
		28	41	55	69	83	97	110	124	138	152	165	179
Flow /min [GPM]	[2]	[478]	[827]	[1171]	[1511]	[1839]	[2153]	[2452]	[2756]	[3027]	[3275]	[3513]	[3673]
	7.6	54	93	132	171	208	243	277	311	342	370	397	415
	[4]	[515]	[872]	[1220]	[1558]	[1886]	[2206]	[2518]	[2816]	[3107]	[3382]	[3647]	[3882]
	15.1	58	99	138	176	213	249	284	318	351	382	412	439
[6]	[524]	[878]	[1214]	[1551]	[1875]	[2199]	[2518]	[2824]	[3113]	[3389]	[3666]		
22.7	59	99	137	175	212	248	284	319	352	383	414		
	114	111	111	110	108	106	105	103	99	95	91		
[8]	[518]	[856]	[1187]	[1524]	[1861]	[2187]	[2499]	[2782]	[3064]	[3334]			
30.3	59	97	134	172	210	247	282	314	346	377			
	151	150	150	149	147	145	144	143	141	136			
[10]	[462]	[797]	[1133]	[1468]	[1799]	[2118]	[2442]	[2739]	[3023]	[3281]			
38	52	90	128	166	203	239	276	309	342	371			
	190	188	187	186	184	184	182	179	176	160			

[3673] } Torque [lb-in ]  
 415 } Nm  
 16 } Speed RPM

# W Series (162-)

## Performance Data

Motors run with high efficiency in all areas designated with a number for torque and speed. For best motor life select a motor to run with a torque and speed range shown in the light shaded area.

Performance data is typical at 120 SUS. Actual data may vary slightly from motor to motor in production.

### 251 cm<sup>3</sup>/r [15.3 in<sup>3</sup>/r] Δ Pressure bar [PSI]

		Continuous										
		[400]	[600]	[800]	[1000]	[1200]	[1400]	[1600]	[1800]	[2000]	[2200]	[2400]
		28	41	55	69	83	97	110	124	140	152	165
Flow /min [GPM]	[2]	[759]	[1194]	[1683]	[2122]	[2535]	[2928]	[3319]	[3634]	[3946]	[4242]	[4553]
	7.6	86 30	135 29	190 29	240 28	286 27	331 27	375 25	411 22	446 17	479 15	514 14
	[4]	[806]	[1257]	[1691]	[2130]	[2563]	[2988]	[3381]	[3799]	[4147]	[4515]	[4849]
	15.1	91 59	142 58	191 58	241 56	290 55	338 55	382 52	429 48	469 47	510 41	548 40
	[6]	[780]	[1219]	[1646]	[2084]	[2515]	[2933]	[3336]	[3716]			
	22.7	88 90	138 88	186 87	235 86	284 85	331 83	377 83	420 79			
	[8]	[720]	[1148]	[1590]	[2029]	[2449]	[2861]	[3236]	[3627]			
	30.3	81 120	130 118	180 117	229 117	277 114	323 112	366 111	410 108			
	[10]	[645]	[1080]	[1513]	[1947]	[2371]	[2779]	[3151]	[3515]			
	37.9	73 148	122 147	171 147	220 145	268 145	314 143	356 141	397 137			
	[12]	[557]	[992]	[1428]	[1864]	[2292]	[2697]	[3087]				
	45.4	63 178	112 177	161 176	211 174	259 174	305 172	349 169				
	[14]	[460]	[888]	[1330]	[1761]	[2191]	[2615]	[3035]				
	53.0	52 208	100 206	150 206	199 203	248 202	295 200	343 197				



### 303 cm<sup>3</sup>/r [18.5 in<sup>3</sup>/r] Δ Pressure bar [PSI]

		Continuous								
		[400]	[600]	[800]	[1000]	[1200]	[1400]	[1600]	[1800]	[2000]
		28	41	55	69	83	97	110	124	140
Flow /min [GPM]	[2]	[920]	[1454]	[1974]	[2480]	[2969]	[3429]	[3859]	[4230]	[4583]
	7.6	104 24	164 24	223 24	280 23	335 22	387 22	436 20	478 18	518 16
	[4]	[960]	[1487]	[2007]	[2513]	[3006]	[3457]	[3905]	[4338]	[4769]
	15.1	108 49	168 49	227 47	284 47	340 46	391 45	441 44	490 41	539 39
	[6]	[911]	[1445]	[1961]	[2473]	[2952]	[3411]	[3842]	[4276]	
	22.7	103 73	163 73	222 72	279 72	334 71	385 69	434 68	483 66	
	[8]	[843]	[1375]	[1888]	[2393]	[2886]	[3350]	[3763]		
	30.3	95 99	155 98	213 97	270 96	326 95	379 94	425 93		
	[10]	[752]	[1274]	[1789]	[2303]	[2792]	[3274]	[3650]		
	37.9	85 123	144 122	202 122	260 120	316 119	370 119	412 118		
	[12]	[652]	[1170]	[1691]	[2199]	[2691]	[3123]			
	45	74 148	132 147	191 146	248 145	304 145	353 144			
	[14]	[526]	[1039]	[1560]	[2064]	[2548]	[2999]			
	53	59 172	117 172	176 171	233 170	288 169	339 168			
[16.5]	[353]	[864]	[1367]	[1876]	[2369]					
62	40 203	98 203	154 201	212 200	268 200					

[4583]  
518 } Torque [lb-in ]  
16 } N·m  
16 } Speed RPM

### 374 cm<sup>3</sup>/r [22.8 in<sup>3</sup>/r] Δ Pressure bar [PSI]

		Continuous							
		[400]	[600]	[800]	[1000]	[1200]	[1400]	[1600]	[1800]
		28	41	55	69	83	97	110	124
Flow /min [GPM]	[2]	[1086]	[1753]	[2365]	[2960]	[3533]	[4025]	[4484]	[4970]
	7.6	123 20	198 19	267 17	334 16	399 14	455 12	507 12	562 11
	[4]	[1152]	[1797]	[2431]	[3048]	[3624]	[4129]	[4599]	
	15.1	130 39	203 39	275 38	344 36	409 34	467 33	520 31	
	[6]	[1099]	[1749]	[2377]	[2996]	[3557]	[4077]		
	22.7	124 60	198 58	269 57	339 56	402 54	461 53		
	[8]	[1018]	[1662]	[2290]	[2894]	[3440]	[3952]		
	30.3	115 80	188 79	259 78	327 76	389 75	447 74		
	[10]	[940]	[1582]	[2210]	[2812]	[3346]	[3816]		
	37.9	106 100	179 99	250 97	318 96	378 95	431 95		
	[12]	[809]	[1454]	[2077]	[2677]	[3216]			
	45.4	91 120	164 119	235 117	302 116	363 115			
	[14]	[648]	[1284]	[1907]	[2506]	[3033]			
	53.0	73 141	145 139	215 138	283 137	343 137			
	[16]	[485]	[1107]	[1722]	[2315]	[2838]			
	60.6	55 160	125 159	195 157	262 157	321 157			
	[18]	[307]	[930]	[1543]	[2133]				
	68.1	35 180	105 179	174 178	241 178				
[20]	[111]	[730]	[1342]	[1939]					
75.7	13 201	82 199	152 198	219 197					

 Continuous  
 Intermittent

# W Series (162-)

## Dimensions

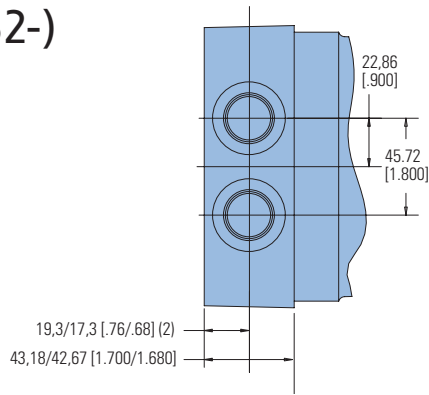

## Ports

7/8-14 SAE O-Ring Ports

G1/2 BSP Straight Thread Port

Manifold (15/16-18 Mounting Threads)

## Standard Rotation Viewed from Shaft End

Port A Pressurized — CW

Port B Pressurized — CCW

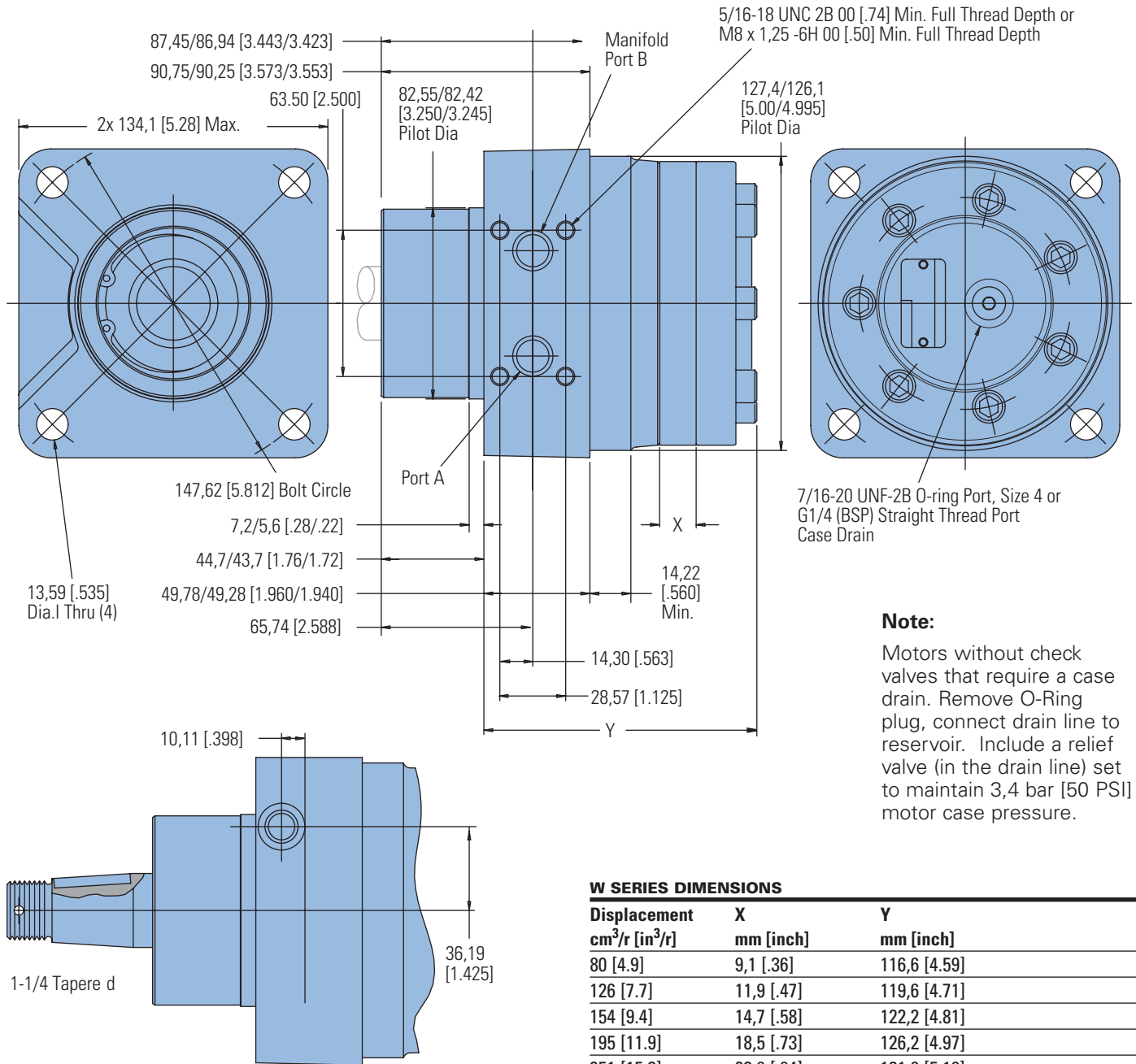

B-5

## Note:

Motors without check valves that require a case drain. Remove O-Ring plug, connect drain line to reservoir. Include a relief valve (in the drain line) set to maintain 3,4 bar [50 PSI] motor case pressure.

## W SERIES DIMENSIONS

Displacement cm <sup>3</sup> /r [in <sup>3</sup> /r]	X mm [inch]	Y mm [inch]
80 [4.9]	9,1 [.36]	116,6 [4.59]
126 [7.7]	11,9 [.47]	119,6 [4.71]
154 [9.4]	14,7 [.58]	122,2 [4.81]
195 [11.9]	18,5 [.73]	126,2 [4.97]
251 [15.3]	23,9 [.94]	131,6 [5.18]
303 [18.5]	29,0 [1.14]	136,4 [5.37]
374 [22.8]	35,6 [1.40]	143,3 [5.64]

# W Series (162-)

## Dimensions Shafts

Recommended Torque:

(373 Nm [275 lb-ft] Dry)

(305 Nm [225 lb-ft] Lub) Plus

Torque required to align the

slotted nut with the Shaft

Crosshole.

### 1 1/4 Tapered

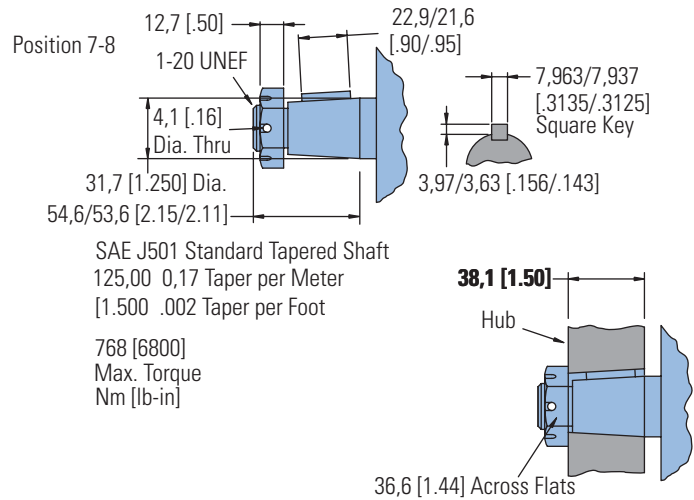
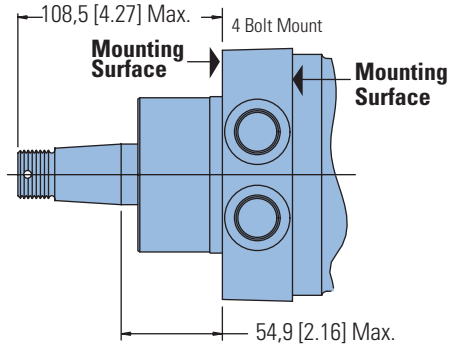

### 1 1/4 Inch Straight

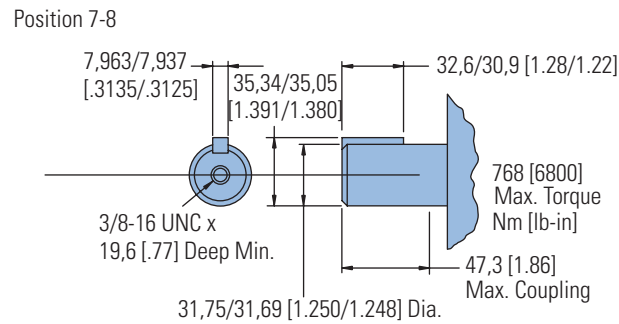
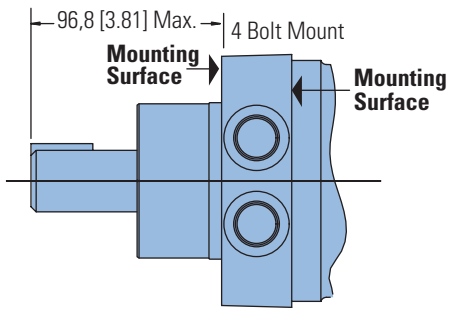

### 32 mm Straight

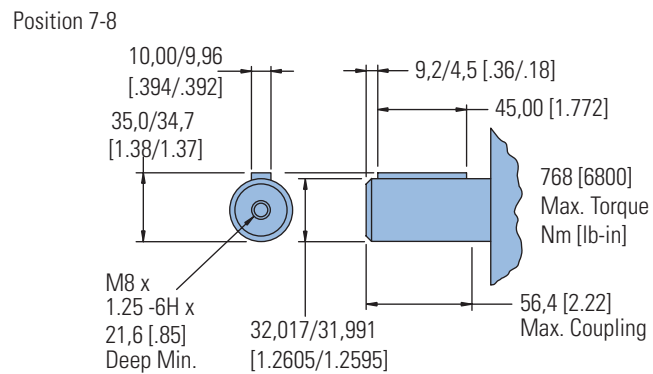
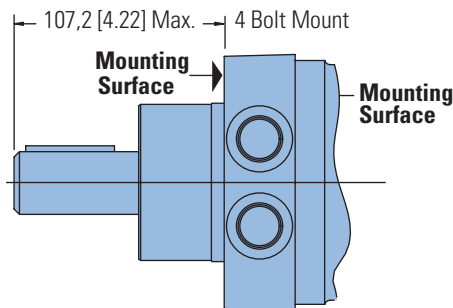

### 1 1/4 14 Tooth Splined

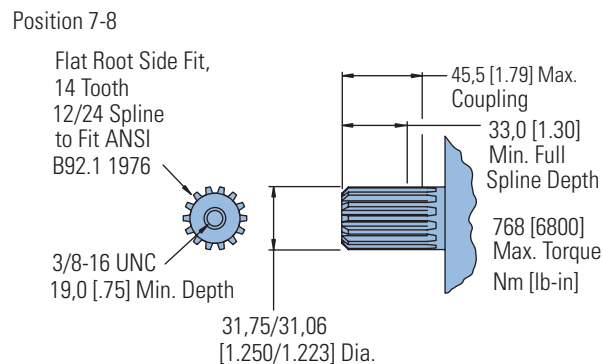
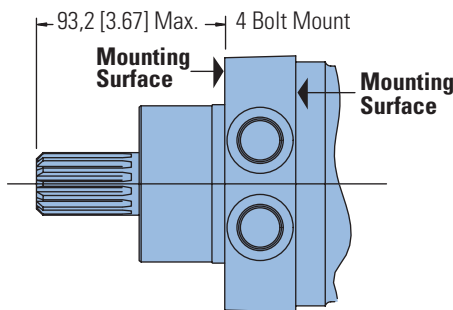

# W Series (162-)

## Shaft Side Load Capacity

- 1) Case pressure needs to be added to the outward axial thrust load and subtracted from inward axial thrustload – Case Pressure bar x 87, 1 [PSI x 1.35]
- 2) Life values in Chart A can be adjusted for speeds up to 200 rpm.  

$$\frac{\text{Life value} \times 100 \text{ rpm}}{\text{application rpm}}$$
- 3) Shaded areas  are intermittent loading.
- 4) To convert application radial load at any load location to sideload at the center of keyway multiply load by the application factor from Chart B.

**Example:**

Side Load: 4849 N @ 120 mm [1090 lbf @ 4.75 inch] from flange.  
 Average Thrust Load: 890 N [200 lbf] inward (toward motor).  
 Case Pressure: 66 bar [960 PSI].  
 Average Speed: 150 rpm.

Expected Life Calculation: Adjust side load value (due to load variation): from Chart B look at 120mm [4.75 inch] read at angled curve for load adjustment factor of 1.38.  
 Adjusted load is: (4849 N [1090 lbf]) x (1.38) = 6690 N [1504 lbf]  
 Thrust Load Value (due to case pressure): (960 PSI) x (1.35) = [1296 lbf] (66 bar) x (87,1) = 5750 N  
 Average thrust load found to be 890 N [200 lbf] inwards so subtract from thrust load due from case pressure:  
 5750 N - 890 N = 4860 N or [1296 lbf] - 200 lbf = [1096 lbf]

Read Life Expectancy from Chart A: Value from chart reading across top to 6672 [1500] (6090 N [1504 lbf]) and down left side to 4895 [1100] (4875 N [1096 lbf])  
 Life = 1800 Hours  
 Speed Adjustment for over 100 rpm:  

$$\frac{(1800 \text{ hrs}) \times (100 \text{ rpm})}{150 \text{ rpm}} = 1200 \text{ Hours}$$

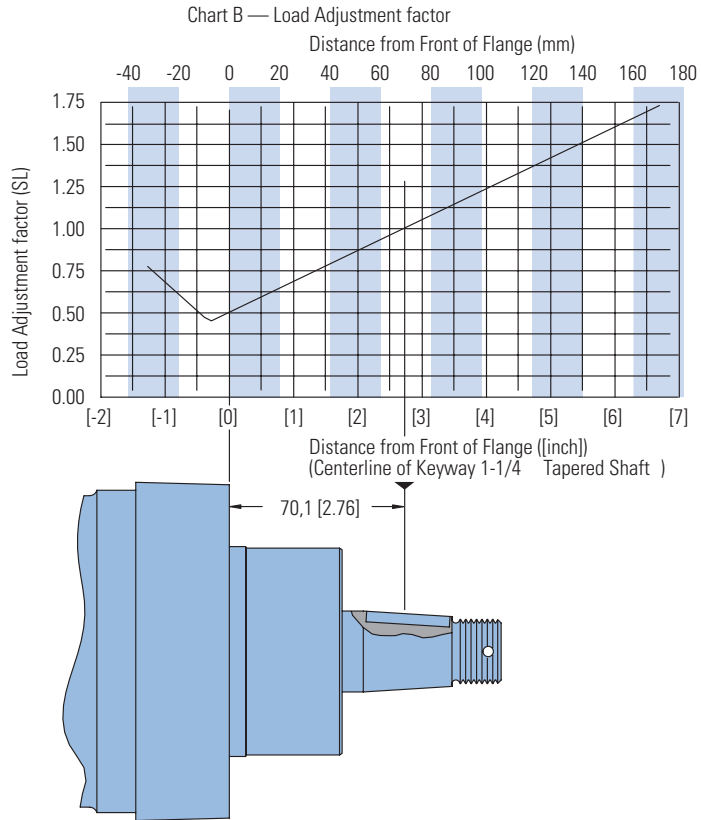

**CHART A – EXPECTED B10 LIFE (HOURS) OF BEARING UNDER VARIOUS LOADS**

Axial Thrust		Radial Load at Centerline of keyway at 100 RPM									
		1110 [250]	2225 [500]	3335 [750]	4450 [1000]	4560 [1250]	6670 [1500]	7785 [1750]	8895 [2000]	11120 N [2500lbf]	13345 N [3000lbf]
445	[100]	410 600	66 000	19 600	8 300	4 200	2 400	1 500	1 000	530	310
1335	[300]	92 700	40 900	19 600	8 300	4 200	2 400	1 500	1 000	530	310
2225	[500]	39 400	20 900	12 400	7 900	4 200	2 400	1 500	1 000	530	310
3115	[700]	21 400	12 600	8 100	5 500	3 900	2 400	1 500	1 000	530	
4005	[900]	13 300	8 400	5 700	4 000	2 900	2 200	1 500	1 000	530	
4895	[1100]	9 000	6 000	4 200	3 100	2 300	1 800	1 400	1 000		
5785	[1300]	6 500	4 500	3 200	2 400	1 900	1 500	1 200	900		
6670	[1500]	4 800	3 500	2 600	2 000	1 500	1 200	1 000			
7560	[1700]	3 700	2 800	2 100	1 600	1 300					
8450	[1900]	3 000	2 200								
8895	[2000]	Max. Thrust									

# W Series (162-)

## Model Code

The following 16-digit coding system has been developed to identify all of the configuration options for the W Series motor. Use this model code to specify a motor with the desired features. All 16-digits of the code must be present when ordering. You may want to photocopy the matrix below to ensure that each number is entered in the correct box.

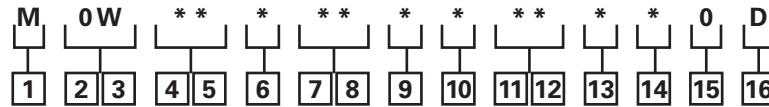

### 1 Product

**M** – Motor

### 2, 3 Series

**0W** – W Series

### 4, 5 Displacement cm<sup>3</sup>/r [in<sup>3</sup>/r]

**05** – 30 [4.9]

**08** – 126 [7.7]

**09** – 154 [9.4]

**12** – 195 [11.9]

**15** – 251 [15.3]

**19** – 303 [18.5]

**23** – 374 [22.8]

### 6 Mounting Type

**B** – 4 Bolt (Wheel) 82,6 [3.25] Pilot Dia. and 13,59 [.535] Dia. Mounting Holes 147,6 [5.81] Dia., B.C., 127,0 127,0 [5.00] rear pilot

### 7, 8 Output Shaft

**02** – 1 1/4 inch Dia. Flat Root Side Fit, 14 Tooth, 12/24 DP 30° Involute Spline with 3/8-16 UNC-2B Thread in End, 33,0 [1.30] Min. Full Spline

**03** – 1 1/4 inch Dia. .125:1 Tapered Shaft Per SAE J501 with 1– 20 UNEF -2A Threaded Shaft End and Slotted Hex Nut, 7,938 [.3125] Square x 22,22 [.875] Straight Key

**04** – 32mm Dia. Straight Shaft with M8 x 1, 25-6H Thread in End, 9,982 [.3930] Wide x 7,995 [.3132] High x 45,00 [1.772] Long Key

**06** – 1 1/4 inch Dia. Straight Shaft with 3/8 – 16 UNC 2B Thread in End, 7,938 [.3125] Square x 34,92 [1.375] Straight Key

### 9 Ports

**A** – 7/8 -14 UNF - 2B SAE O-Ring Port

**B** – G 1/2 (BSP) Straight Thread Port

### 10 Case Flow Options

**A** – 7/16 - 20 UNF - 2B SAE O-Ring Port

**B** – G 1/4 (BSP) Straight Thread Port

**C** – Internal Check Valve

### 11, 12 Special Features (Hardware)

**00** – None

**01** – Viton Seals

### 13 Special Features (Assembly)

**0** – None

**1** – Reverse Rotation

### 14 Paint/Special Packaging

**0** – No Paint, Individual Box

**A** – Low Gloss Black Primer, Bulk Box Option

### 15 Eaton Assigned Code when Applicable

**0** – Assigned Code

### 16 Eaton Assigned Design Code

**D** – Assigned Design Code

# W Series (162-) with Parking Brake

Dimensions

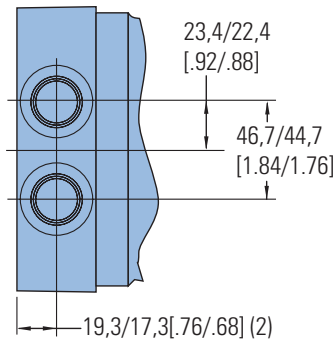

## Ports

7/8 -14 UNF 2B SAE O-Ring Ports (2) or  
G 1/2 (BSP) Straight Thread

## Standard Rotation Viewed from Shaft End

Port A Pressurized — CW

Port B Pressurized — CCW

## Port Dimensions

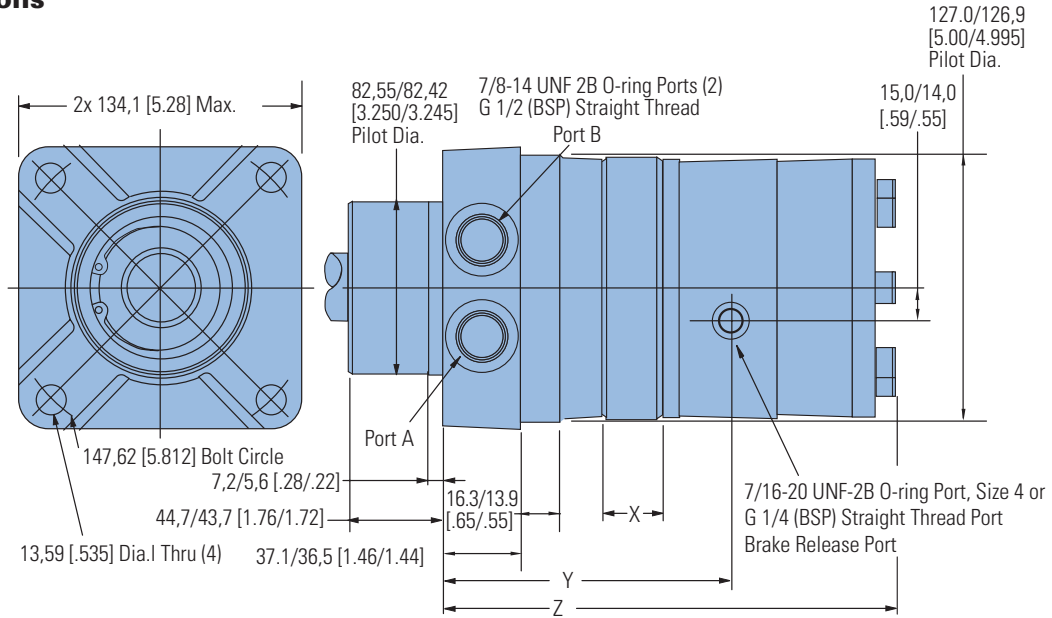

## Mounting Dimensions

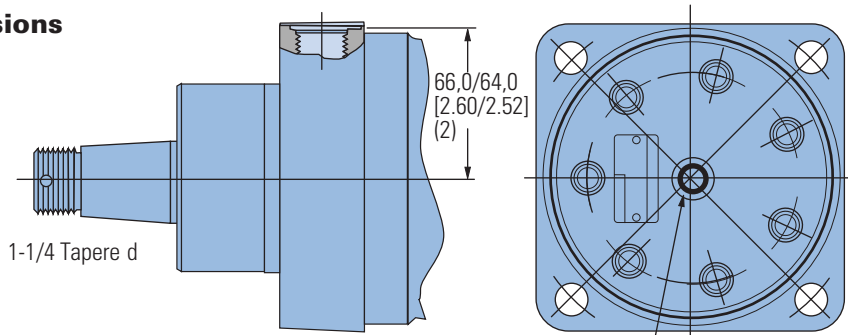

7/16-20 UNF-2B O-ring Port, Size 4 or  
G 1/4 (BSP) Straight Thread Port—  
Manual Brake Release Access Port.  
Tighten plug to manually release brake.

## PORTING AND MOUNTING DIMENSIONS

Displacement cm <sup>3</sup> /r [in <sup>3</sup> /r]	X mm [inch]	Y mm [inch]	Z mm [inch]
80 [4.9]	9,1 [0.36]	119,9 [4.72]	198,4 [7.81]
126 [7.7]	11,9 [0.47]	122,9 [4.84]	201,2 [7.92]
154 [9.4]	14,7 [0.58]	125,5 [4.94]	204,0 [8.03]
195 [11.9]	18,5 [0.73]	129,6 [5.10]	207,8 [8.18]
251 [15.3]	23,9 [0.94]	134,9 [5.31]	213,4 [8.40]
303 [18.5]	29,0 [1.14]	139,7 [5.50]	217,7 [8.59]
374 [22.8]	35,6 [1.40]	146,6 [5.77]	226,8 [8.85]

## SPECIFICATIONS

Brake Release Pressure 205 bar [3000 PSI] Max.; 15 bar [250 PSI] Min.

# W Series, W Series (162-) with Parking Brake

Product Numbers

Use digit prefix —  
162 plus four digit number  
from charts for complete  
product number —  
Example 162-1153.

**Orders will not be accepted  
without three digit prefix.**

## Standard

SHAFT	DISPL. cm <sup>3</sup> /r [in <sup>3</sup> /r] / PRODUCT NUMBER						
	80 [4.9]	126 [7.7]	154 [9.4]	195 [11.9]	251 [15.3]	303 [18.5]	374 [22.8]
Standard	162-1016	-1017	-1018	-1019	-1020	-1021	-1022
w/Case Drain	162-1023	-1024	-1025	-1009	-1008	-1026	-1027

162-1009

## W Series with Parking Brake

SHAFT	DISPL. cm <sup>3</sup> /r [in <sup>3</sup> /r] / PRODUCT NUMBER						
	80 [4.9]	126 [7.7]	154 [9.4]	195 [11.9]	251 [15.3]	303 [18.5]	374 [22.8]
Standard	162-1143	-1144	-1145	-1146	-1183	-1148	-1149

162-1146

### Note:

All above motors have  
1-1/4 inch tapered output  
shaft, 7/8 inch O-Ring Ports,  
internal check valves.

For W Series Motors with  
a configuration not shown  
in the chart above: Use the  
model code number system  
to specify the product in  
detail. (see page B-5-8  
and use the model code  
supplement shown on page  
B-5-11 for spring-applied  
hydraulic-release parking  
brake).



# W Series with Parking Brake (162-)

Model Code

The following 16-digit coding system has been developed to identify all of the configuration options for the W motor. Use this model code to specify a motor with the desired features. All 16-digits of the code must be present when ordering. You may want to photocopy the matrix below to ensure that each number is entered in the correct box.

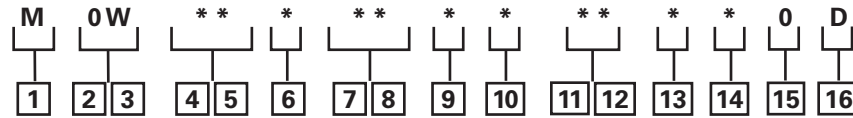

## 1 Product

**M** – Motor

## 2, 3 Series

**OW** – W Series with Parking Brake

## 4, 5 Displacement cm<sup>3</sup>/r [in<sup>3</sup>/r]

**05** – 30 [4.9]

**08** – 126 [7.7]

**09** – 154 [9.4]

**12** – 195 [11.9]

**15** – 251 [15.3]

**19** – 303 [18.5]

**23** – 374 [22.8]

## 6 Mounting Type

**B** – 4 Bolt (Wheel) 82,6 [3.25] Pilot Dia. and 13,59 [.535] Dia. Mounting Holes 147,6 [5.81] Dia., B.C., 127,0 127,0 [5.00] rear pilot

## 7, 8 Output Shaft

**02** – 1 1/4 inch Dia. Flat Root Side Fit, 14 Tooth, 12/24 DP 30° Involute Spline with 3/8-16 UNC-2B Thread in End, 33,0 [1.30] Min. Full Spline

**03** – 1 1/4 inch Dia. .125:1 Tapered Shaft Per SAE J501 with 1– 20 UNEF -2A Threaded Shaft End and Slotted Hex Nut, 7,938 [.3125] Square x 22,22 [.875] Straight Key

**04** – 32mm Dia. Straight Shaft with M8 x 1, 25-6H Thread in End, 9,982 [.3930] Wide x 7,995 [.3132] High x 45,00 [1.772] Long Key

**06** – 1 1/4 inch Dia. Straight Shaft with 3/8 – 16 UNC 2B Thread in End, 7,938 [.3125] Square x 34,92 [1.375] Straight Key

## 9 Ports

**A** – 7/8 -14 UNF - 2B SAE O-Ring Port

**B** – G 1/2 (BSP) Straight Thread Port

## 10 Case Flow Options

**A** – 7/16 - 20 UNF - 2B SAE O-Ring Port

**B** – G 1/4 (BSP) Straight Thread Port

**C** – Internal Check Valve

## 11, 12 Special Features (Hardware)

**00** – None

**01** – Viton Seals

**11** – Spring-applied hydraulic-release brake

## 13 Special Features (Assembly)

**0** – None

**1** – Reverse Rotation

## 14 Paint/Special Packaging

**0** – No Paint, Individual Box

**A** – Low Gloss Black Primer - Individual Box

## 15 Eaton Assigned Code when Applicable

**0** – Assigned Code

## 16 Eaton Assigned Design Code

**D** – Assigned Design Code

B-5



C-1

C-2

C-3

C-4

C-5

C-6

# Disc Valve Hydraulic Motors

## Highlights

### Product Description

In the late 1950's the original low speed, high torque hydraulic motor was developed from a pump Geroter element consisting of an internal gear ring and a mating gear or star. While attaching the internal gear ring to the housing as a non moving part, oil was ported to pressurize and turn the internal star in an orbit around a center point. This slow turning star coupled with a splined drive to the output shaft became the Char-Lynn Orbit® motor.

A few years after this original Char-Lynn Orbit motor was introduced another original motor concept went into production. This motor had rolls incorporated into the internal gear ring, this element was identified by the name Geroler and is a registered trade name of Eaton Hydraulics. From these early years the Geroler motor has seen many design changes to make these Geroler motors the best the industry has to offer. Examine the simplicity of these Geroler disc valve motors shown below. Also examine all the following pages for high value Char-Lynn disc valve motors from Eaton Hydraulics.

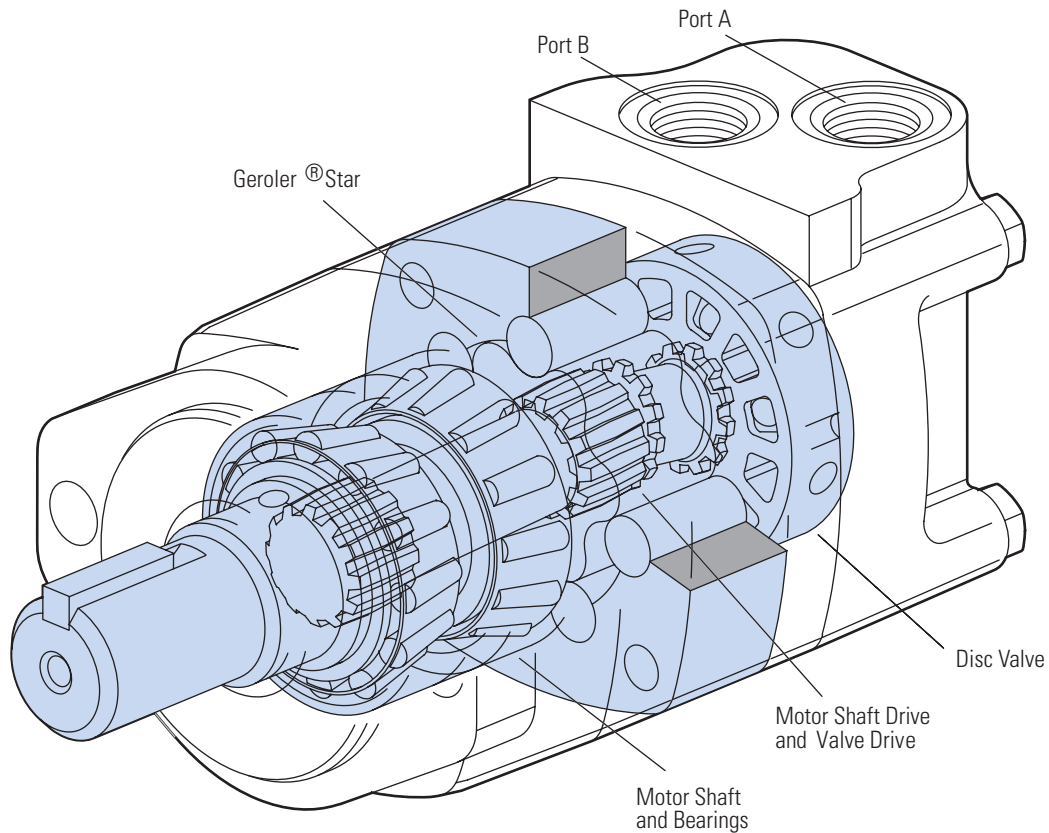

# Features, Benefits, and Applications

## Features

Char-Lynn Hydraulic motors provide design flexibility. All disc valve motors are available with various configurations consisting of:

- Displacement (Geroler size)
- Output Shaft
- No Shaft and Bearing Assembly (Bearingless Motor)
- Port Configuration
- Mounting Flange
- Other Special Features

## Benefits

- Lowest pressure drop motor in the industry
- Widest range of options
- The most experienced manufacturer of LSHT motors

## Applications

- Swing motor
- Brush Cutters & mowers
- Harvesting equipment
- Directional boring
- Turf equipment
- Skid Steer loaders
- Fairway mowers
- Harvesters
- Mowing
- Snow removal
- Sprayers
- Trencher
- Wood products
- Grinders and mixers
- Forestry equipment
- Irrigation reels

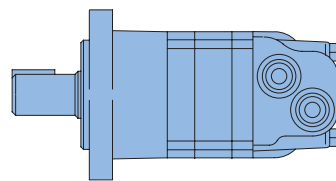

### Standard Motor

The standard motor mounting flange is located as close to the output shaft as possible. This type of mounting supports the motor close to the shaft load. This mounting flange is also compatible with many standard gear boxes.

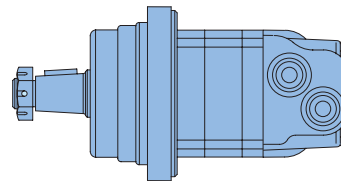

### Wheel Motor

The wheel motor mounting flange is located near the center of the motor which permits part or all of the motor to be located inside the wheel or roller hub. In traction drive applications, loads can be positioned over the motor bearings for best bearing life. This wheel motor mounting flange provides design flexibility in many applications.

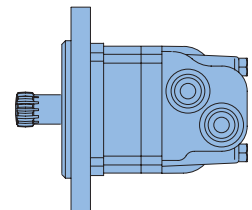

### Bearingless Motor

The bearingless motor has the same drive components as the standard and wheel motors (with the exception that the motor is assembled without the output shaft, bearings and bearing housing). The bearingless motor is especially suited for applications such as gear boxes, winch drives, reel and roll drives. Bearingless motor applications must be designed with a bearing supported internal spline to mate with the bearingless motor drive. Product designs using these hydraulic motors provide considerable cost savings.

C-1

C-2

C-3

C-4

C-5

C-6

# Table of Contents

Highlights	C-ii
Features, Benefits and Applications	C-iii
Table of Contents	C-iv

## 2000 Series

Highlights	C-1-1
Specifications	C-1-2
Performance Data	C-1-3
Dimensions	C-1-9
Installation Information	C-1-15
Shaft Side Load Capacity	C-1-19
Case Pressure and Case Porting	C-1-20
Product Numbers	C-1-24
Model Code	C-1-25

## 2000 Series Two-Speed

Description	C-1-26
Performance Data	C-1-26
Typical Hydraulic Circuit	C-1-27
Specifications	C-1-28
Dimensions	C-1-29
Product Numbers	C-1-31

## 4000 Compact Series

Highlights	C-2-1
Specifications	C-2-2
Performance Data	C-2-3
Dimensions	C-2-9
Installation Information	C-2-12
Shaft Side Load Capacity	C-2-17
Case Pressure and Case Port	C-2-18
Model Code	C-2-22

## Delta Series

Highlights	C-3-1
Specifications	C-3-2
Performance Data	C-3-3
Dimensions	C-3-9
Installation Information	C-3-10
Model Code	C-3-11

## 4000 Series

Highlights	C-4-1
Specifications	C-4-2
Performance Data	C-4-3
Dimensions	C-4-8
Installation Information	C-4-11
Shaft Side Load Capacity	C-4-13
Case Pressure and Case Port	C-4-14
Product Numbers	C-4-16
Model Code	C-4-17

## 6000 Series

Highlights	C-5-1
Specifications	C-5-2
Performance Data	C-5-3
Dimensions	C-5-8
Installation Information	C-5-12
Shaft Side Load Capacity	C-5-14
Case Pressure and Case Port	C-5-15
Dimensions Ports	C-5-16
Product Numbers	C-5-17
Model Code	C-5-18

## 10,000 Series

Highlights	C-6-1
Specifications	C-6-2
Performance Data	C-6-3
Dimensions	C-6-5
Installation Information	C-6-8
Side Shaft Load Capacity	C-6-10
Product Numbers	C-6-12
Model Code	C-6-13

# 2000 Series

## Highlights

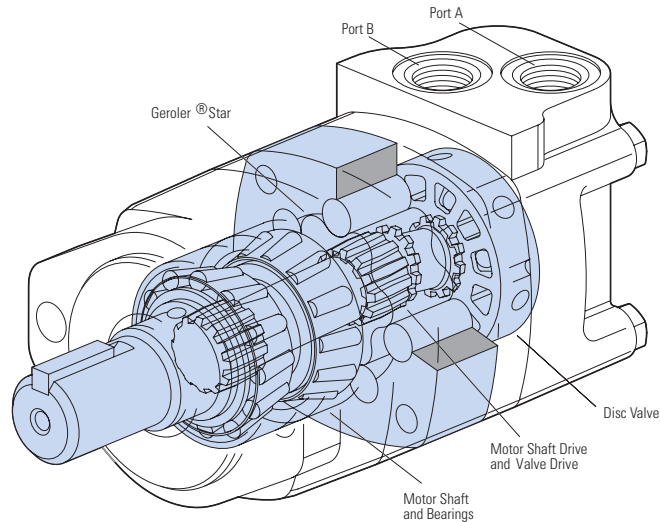

### Features

- Three zone design for longer life and true bi-directionality.
- Bearings that meet the highest standards of the industry
- Options to optimize performance in every application
- Integrated cross-over relief valve option

### Benefits

- Easy to design in a system
- Proven reliability and performance in tough applications
- Compact design that maximizes power density

### Applications

- Skid Steer Attachments
- Swing Motor
- Brush Cutters & Mowers
- Harvesting Equipment
- Directional Boring any place pressure relief protection is optimal for system or motor performance and life
- Turf equipment

C-1

### Description

The popular 2000 Series provides torque up to 7500 lb-in. This proven design is reliable and durable. Eaton has added options that make the motor more flexible to use in a wide variety of applications. The expanded displacement range using patented “Drive in Drive” technology is the latest innovation in the 2000 series of motors

### 2000 Series

Geroler Element	13 Displacements
Flow l/min [GPM]	75 [20] Continuous**
	115 [30] Intermittent*
Speed RPM	1215 Cont.**
	1215 Inter.*
Pressure bar [PSI]	205 [3000] Cont.**
	310 [4500] Inter.*
Torque Nm [lb-in]	845 [7470] Cont.**
	930 [8225] Inter.*

\*\* Continuous— (Cont.) Continuous rating, motor may be run continuously at these ratings.

\* Intermittent— (Inter.) Intermittent operation, 10% of every minute.



Harvester



Paving Equipment



Conveyors



Boom Lifts

# 2000 Series

## Specifications

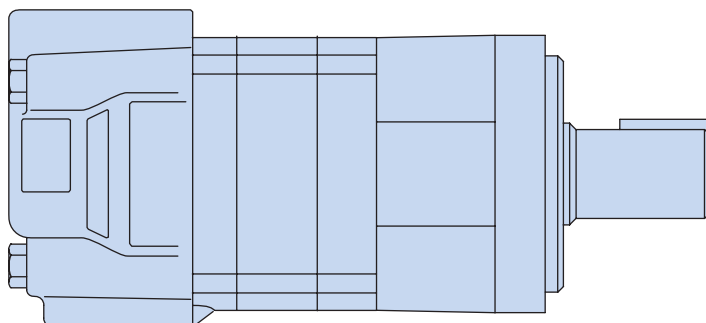

### SPECIFICATION DATA – 2000 SERIES MOTORS

Displ. cm <sup>3</sup> /r [in <sup>3</sup> /r]		34 [2.1]	41 [2.5]	66 [4.0]	80 [4.9]	90 [5.5]	100 [6.2]	130 [8.0]	160 [9.6]	195 [11.9]	245 [14.9]	305 [18.7]	395 [24.0]	490 [29.8]
Max Speed	Continuous	1215	1104	1075	908	836	742	576	477	385	308	246	191	153
(RPM) @ Flow	Intermittent	1215	1216	1214	908	1042	924	720	713	577	462	365	287	230
Flow	Continuous	42 [11]	45 [12]	72 [19]	75 [20]	75 [20]	75 [20]	75 [20]	75 [20]	75 [20]	75 [20]	75 [20]	75 [20]	75 [20]
l/min [GPM]	Intermittent	42 [11]	53 [14]	87 [23]	75 [20]	95 [25]	95 [25]	95 [25]	115 [30]	115 [30]	115 [30]	115 [30]	115 [30]	115 [30]
Torque*	Continuous	98 [864]	112 [988]	186 [1643]	235 [2065]	265 [2326]	295 [2630]	385 [3420]	455 [4040]	540 [4780]	660 [5850]	765 [6750]	775 [6840]	845 [7470]
Nm [lb-in]	Intermittent	141 [1250]	169 [1497]	276 [2446]	345 [3035]	390 [3458]	445 [3950]	560 [4970]	570 [5040]	665 [5890]	820 [7250]	885 [7820]	925 [8170]	930 [8225]
Pressure	Continuous	205 [3000]	205 [3000]	205 [3000]	205 [3000]	205 [3000]	205 [3000]	205 [3000]	205 [3000]	205 [3000]	205 [3000]	205 [3000]	155 [2250]	120 [1750]
	Intermittent	310 [4500]	310 [4500]	310 [4500]	310 [4500]	310 [4500]	310 [4500]	310 [4500]	260 [3750]	260 [3750]	260 [3750]	240 [3500]	190 [2750]	140 [2000]
Δ bar [Δ PSI]	Peak	310 [4500]	310 [4500]	310 [4500]	310 [4500]	310 [4500]	310 [4500]	310 [4500]	310 [4500]	310 [4500]	310 [4500]	310 [4500]	225 [3250]	170 [2500]
Weight	Standard or Wheel Mount	8.8 [19.4]	8.8 [19.4]	8.8 [19.4]	9.3 [20.5]	9.3 [20.5]	9.5 [21.0]	9.8 [21.5]	10.0 [22.0]	10.4 [23.0]	11.3 [25.0]	11.3 [25.0]	11.8 [26.0]	12.2 [27.0]
kg [lb]	Bearingless	6.8 [15.0]	6.8 [15.0]	6.8 [15.0]	7.3 [16.0]	7.3 [16.0]	7.5 [16.5]	7.7 [17.0]	7.9 [17.5]	8.4 [18.5]	9.3 [20.5]	9.3 [20.5]	9.8 [21.5]	10.2 [22.5]

#### Note:

To assure best motor life, run motor for approximately one hour at 30% of rated pressure before application to full load. Be sure motor is filled with fluid prior to any load applications.

#### Maximum Inlet Pressure:

310 bar [4500 PSI]  
Do not exceed Δ pressure rating (see chart above).

#### Maximum Return Pressure:

310 bar [4500 PSI] with case drain line installed.  
Do not exceed Δ pressure rating (see chart above).

#### Δ bar [Δ PSI] :

The true pressure difference between inlet port and outlet port

#### Continuous Rating:

Motor may be run continuously at these ratings

#### Intermittent Operation:

10% of every minute

#### Peak Operation:

1% of every minute

#### Recommended Fluids:

Premium quality, anti-wear type hydraulic oil with a viscosity of not less than 70 SUS at operating temperature.

#### Recommended System Operating Temp.:

-34°C to 82°C [-30°F to 180°F]

#### Recommended Filtration:

per ISO Cleanliness Code, 4406: 20/18/13

# 2000 Series

## Performance Data

Motors run with high efficiency in all areas designated with a number for torque and speed. For best motor life select a motor to run with a torque and speed range shown in the light shaded area.

Performance data is typical at 120 SUS. Actual data may vary slightly from unit to unit in production.

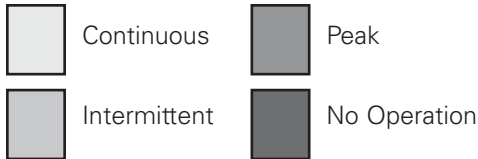

**34cm<sup>3</sup>/r [2.1 in<sup>3</sup>/r]**  
**ΔPressure Bar [PSI]**

	[500]	[1000]	[1500]	[2000]	[2500]	[3000]	[3500]	[4000]	[4500]
	34	69	103	138	172	207	241	276	310
[2]	[114]	[262]	[405]	[549]					
8	13 210	30 189	46 178	62 162					
[4]	[110]	[256]	[404]	[552]	[704]	[828]	[962]		
15	12 432	29 416	46 393	62 363	80 347	94 313	109 284		
[6]	[115]	[249]	[400]	[550]	[708]	[864]	[996]	[1099]	[1250]
23	13 651	28 636	45 613	62 580	80 546	98 518	113 467	124 425	141 404
[8]	[126]	[232]	[393]	[548]	[702]	[856]	[1003]	[1135]	[1244]
30	14 856	26 856	44 830	62 795	79 759	97 712	113 657	128 578	141 549
[10]	[114]	[239]	[386]	[541]	[697]	[850]	[995]	[1136]	[1261]
38	13 1105	27 1077	44 1049	61 1015	79 975	96 923	112 859	128 775	142 707
[11]	[99]	[231]	[380]	[533]	[679]	[834]	[987]	[1133]	[1245]
42	11 1215	26 1191	43 1160	60 254	77 1073	94 1023	112 945	128 854	141 819

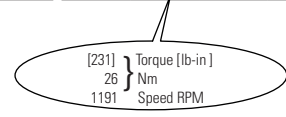

**41cm<sup>3</sup>/r [2.5 in<sup>3</sup>/r]**  
**ΔPressure Bar [PSI]**

	[500]	[1000]	[1500]	[2000]	[2500]	[3000]	[3500]	[4000]	[4500]
	34	69	103	138	172	207	241	276	310
[2]	[138]	[306]	[468]	[659]					
8	16 171	35 160	53 156	74 135					
[4]	[129]	[296]	[466]	[552]	[807]	[966]	[1110]	[1316]	[1421]
15	15 364	33 352	53 336	62 363	91 295	109 272	125 248	145 235	161 217
[6]	[135]	[300]	[473]	[550]	[818]	[985]	[1147]	[1292]	[1495]
23	15 550	34 535	53 516	62 580	92 465	111 437	130 406	146 352	169 326
[8]	[130]	[285]	[461]	[548]	[816]	[988]	[1150]	[1320]	[1477]
30	15 734	32 722	52 699	62 795	92 641	112 616	130 568	149 519	167 470
[10]	[137]	[276]	[455]	[541]	[802]	[979]	[1153]	[1329]	[1497]
38	15 921	31 909	51 884	61 1015	91 825	111 784	130 743	150 687	169 635
[12]	[119]	[268]	[441]	[1340]	[794]	[969]	[1141]	[1321]	[1494]
45	13 1104	30 1093	50 1068	150 254	90 1003	109 972	129 902	149 833	169 785
[14]				[597]	[787]	[953]	[1124]	[1309]	[1479]
53				67 1216	89 1184	108 1144	127 1073	148 997	167 921

C-1

**66cm<sup>3</sup>/r [4.0 in<sup>3</sup>/r]**  
**ΔPressure Bar [PSI]**

	[500]	[1000]	[1500]	[2000]	[2500]	[3000]	[3500]	[4000]	[4500]
	34	69	103	138	172	207	241	276	310
[2]	[226]	[503]	[746]	[987]					
8	26 103	57 102	84 93	112 88					
[4]	[226]	[508]	[791]	[1072]	[1342]	[1609]	[1810]	[2012]	[2220]
15	26 214	57 208	89 194	121 188	152 181	182 172	204 158	227 136	251 134
[6]	[216]	[503]	[792]	[1075]	[1353]	[1629]	[1890]	[2123]	[2332]
23	24 329	57 318	89 305	121 290	153 284	184 270	214 257	240 235	264 228
[8]	[208]	[495]	[781]	[1070]	[1352]	[1633]	[1910]	[2186]	[2405]
30	23 444	56 430	88 415	121 401	153 387	184 372	216 355	247 339	272 320
[10]	[195]	[486]	[777]	[1070]	[1359]	[1643]	[1920]	[2191]	[2446]
38	22 560	55 544	88 529	121 513	154 497	186 480	217 461	248 440	276 419
[12]	[182]	[472]	[757]	[1052]	[1345]	[1627]	[1912]	[2189]	[2444]
45	21 672	53 658	86 643	119 623	152 606	184 586	216 565	247 547	276 528
[14]	[187]	[459]	[750]	[1045]	[1339]	[1633]	[1926]	[2198]	[2443]
53	21 788	52 776	85 758	118 738	151 720	184 701	218 680	248 654	276 640
[16]	[182]	[436]	[724]	[1019]	[1313]	[1604]	[1915]	[2181]	[2443]
61	21 901	49 887	82 870	115 849	148 829	181 808	216 785	246 753	276 734
[19]	[167]	[407]	[702]	[996]	[1283]	[1588]	[1866]	[2157]	[2441]
72	19 1075	46 1061	79 1040	113 1017	145 996	179 967	211 950	244 919	276 876
[21]	[162]	[391]	[679]	[967]	[1255]	[1556]	[1840]	[2268]	[2432]
79	18 1188	44 1175	77 1152	109 1129	142 1105	176 1075	208 1052	256 987	275 988
[23]				[1226]	[1523]	[1814]	[1985]	[2387]	
87				139 1214	172 1185	205 1155	224 1125	270 1107	



# 2000 Series

## Performance Data

Motors run with high efficiency in all areas designated with a number for torque and speed. For best motor life select a motor to run with a torque and speed range shown in the light shaded area.

Performance data is typical at 120 SUS. Actual data may vary slightly from unit to unit in production.

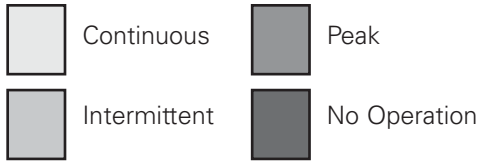

**80cm<sup>3</sup>/r [4.9 in<sup>3</sup>/r]**  
**ΔPressure Bar [PSI]**

	[500]	[1000]	[1500]	[2000]	[2500]	[3000]	[3500]	[4000]	[4500]
	35	70	105	140	170	205	240	275	310
[.25]	[210] 25 3	[420] 45 1							
[.5]	[250] 30 17	[500] 50 8	[740] 85 3						
[1]	[330] 35 44	[670] 75 40	[990] 110 37	[1300] 145 34	[1550] 175 28	[1800] 205 22	[1950] 220 14	[2110] 240 2	
[2]	[330] 35 90	[670] 75 85	[995] 110 81	[1310] 150 78	[1580] 180 72	[1840] 210 65	[2100] 235 57	[2365] 265 49	[2630] 295 42
[4]	[325] 35 182	[670] 75 176	[1005] 115 170	[1330] 150 166	[1620] 185 159	[1920] 215 152	[2200] 250 140	[2480] 280 128	[2765] 310 117
[6]	[320] 35 273	[665] 75 267	[1010] 115 259	[1340] 150 254	[1655] 185 246	[1975] 225 238	[2270] 255 223	[2570] 290 207	[2880] 325 192
[8]	[310] 35 365	[660] 75 375	[1015] 115 349	[1345] 150 341	[1685] 190 333	[2020] 230 325	[2330] 265 306	[2640] 280 286	[2960] 335 266
[10]	[300] 35 456	[650] 75 448	[1010] 115 439	[1350] 155 429	[1700] 190 420	[2050] 230 411	[2370] 270 388	[2690] 305 364	[3010] 340 341
[12]	[285] 30 547	[640] 70 537	[1005] 115 530	[1350] 155 516	[1705] 195 507	[2065] 235 497	[2390] 270 470	[2715] 305 442	[3035] 345 415
[14]	[270] 30 638	[625] 70 629	[990] 110 622	[1340] 150 603	[1705] 195 593	[2065] 235 584	[2395] 270 553	[2720] 305 521	[3030] 340 490
[16]	[255] 30 729	[610] 70 720	[975] 110 714	[1330] 150 689	[1690] 190 679	[2055] 230 670	[2385] 270 635	[2700] 305 599	[2995] 340 564
[18]	[230] 25 818	[590] 65 810	[955] 110 795	[1310] 150 775	[1680] 190 765	[2025] 230 756	[2355] 265 717	[2660] 300 677	[2935] 330 638
[20]	[210] 25 908	[570] 65 901	[930] 105 880	[1290] 145 861	[1645] 185 851	[1985] 225 842	[2305] 260 799	[2600] 295 755	[2845] 320 712

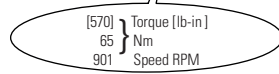

**90cm<sup>3</sup>/r [5.5 in<sup>3</sup>/r]**  
**ΔPressure Bar [PSI]**

	[250]	[500]	[1000]	[1500]	[2000]	[2500]	[3000]	[3500]	[4000]	[4500]
	15	35	70	105	140	170	205	240	275	310
[.25]	[124] 14 5	[233] 26 2	[471] 53 1							
[.5]	[133] 15 15	[273] 31 13	[555] 63 6	[832] 94 2						
[1]	[151] 17 39	[358] 40 39	[744] 84 35	[1091] 123 32	[1424] 161 28	[1697] 192 21	[1952] 221 13	[2189] 247 12	[2368] 268 2	
[2]	[151] 17 82	[358] 40 80	[744] 84 76	[1099] 124 72	[1439] 163 68	[1737] 196 61	[2015] 228 50	[2293] 259 38	[2570] 290 29	[2855] 323 20
[4]	[151] 17 167	[350] 40 163	[899] 102 158	[1113] 126 152	[1473] 166 148	[1800] 203 139	[2132] 241 126	[2454] 277 115	[2775] 314 102	[3100] 350 90
[6]	[142] 16 250	[348] 39 245	[736] 83 240	[613] 69 233	[1492] 169 227	[1851] 209 218	[2208] 249 203	[2552] 288 191	[2898] 327 176	[3249] 367 161
[8]	[133] 15 35	[338] 38 328	[729] 82 329	[1128] 127 314	[1509] 170 306	[1890] 214 295	[2269] 256 281	[2635] 298 266	[3000] 339 249	[3367] 380 231
[10]	[124] 14 418	[331] 37 410	[724] 82 404	[1130] 128 395	[1521] 172 385	[1912] 216 373	[2309] 261 361	[2670] 302 342	[3036] 343 322	[3398] 384 302
[12]	[106] 12 502	[315] 36 493	[714] 81 485	[1127] 127 477	[1525] 172 464	[1924] 217 451	[2326] 263 441	[2704] 306 417	[3082] 348 394	[3458] 391 372
[14]	[98] 11 585	[298] 34 575	[706] 80 567	[1115] 126 559	[1525] 172 543	[1924] 217 529	[2326] 263 521	[2707] 306 493	[3080] 348 467	[3450] 390 431
[16]	[80] 9 670	[285] 32 658	[688] 78 650	[1107] 125 641	[1510] 171 622	[1907] 215 607	[2311] 261 610	[2697] 305 568	[3070] 347 541	[3432] 388 513
[18]	[62] 7 753	[262] 30 740	[673] 76 732	[1087] 123 719	[1490] 168 701	[1892] 214 685	[2281] 258 680	[2662] 301 643	[3030] 342 613	[3381] 382 583
[20]	[53] 6 836	[242] 27 822	[644] 73 814	[1045] 118 796	[1447] 163 780	[1850] 209 765	[2246] 254 748	[2617] 296 719	[2988] 338 686	[3301] 373 653
[22]	[35] 4 920	[231] 26 916	[639] 72 907	[1047] 118 895	[1437] 162 876	[1836] 207 854	[2218] 251 749	[2599] 294 803	[2981] 337 774	
[24]	[18] 2 1003	[204] 23 1000	[612] 69 991	[1011] 114 978	[1366] 154 960	[1792] 202 940	[2182] 247 918	[2573] 291 882	[2963] 335 850	
[25]		[195] 22 1042	[594] 67 1033	[994] 112 1020	[1384] 156 1003	[1765] 199 984	[2173] 246 954	[2564] 290 921		

# 2000 Series

## Performance Data

Motors run with high efficiency in all areas designated with a number for torque and speed. For best motor life select a motor to run with a torque and speed range shown in the light shaded area.

Performance data is typical at 120 SUS. Actual data may vary slightly from unit to unit in production.

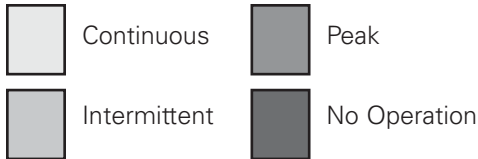

100cm<sup>3</sup>/r [6.2 in<sup>3</sup>/r]  
ΔPressure Bar [PSI]

	[250] 15	[500] 35	[1000] 70	[1500] 105	[2000] 140	[2500] 170	[3000] 205	[3500] 240	[4000] 275	[4500] 310
[.25]	[140] 15 4	[260] 30 2								
[.5]	[150] 15 13	[300] 35 9	[620] 70 5	[940] 105 2						
[1]	[170] 20 35	[390] 45 34	[830] 95 31	[1210] 135 28	[1570] 175 23	[1870] 210 15	[2130] 240 6			
[2]	[170] 20 73	[390] 45 71	[830] 95 68	[1220] 140 63	[1590] 180 59	[1920] 215 51	[2220] 250 38	[2520] 285 24	[2810] 315 14	[3120] 355 4
[4]	[170] 20 148	[380] 45 145	[820] 90 141	[1240] 140 136	[1640] 185 131	[2010] 225 121	[2380] 270 104	[2750] 310 94	[3120] 355 80	[3490] 395 69
[6]	[160] 20 222	[380] 45 219	[820] 90 215	[1260] 140 209	[1670] 190 202	[2080] 235 192	[2480] 280 172	[2880] 325 163	[3280] 370 149	[3680] 415 134
[8]	[150] 15 297	[370] 40 294	[810] 90 288	[1260] 140 281	[1700] 190 273	[2130] 240 261	[2560] 290 243	[2990] 340 231	[3420] 385 216	[3840] 435 200
[10]	[140] 15 371	[368] 40 367	[810] 90 362	[1270] 145 354	[1720] 195 344	[2160] 245 330	[2610] 295 316	[3020] 340 300	[3440] 390 283	[3850] 435 266
[12]	[120] 15 445	[350] 40 442	[800] 90 436	[1270] 145 427	[1730] 195 415	[2180] 245 399	[2630] 295 389	[3070] 345 369	[3510] 395 350	[3950] 445 332
[14]	[110] 10 519	[330] 35 516	[800] 90 509	[1260] 140 500	[1740] 195 486	[2180] 245 469	[2630] 295 463	[3070] 345 437	[3500] 395 417	[3940] 445 378
[16]	[90] 10 594	[320] 35 591	[780] 90 583	[1260] 140 573	[1720] 195 558	[2160] 245 540	[2610] 295 537	[3060] 345 506	[3500] 395 485	[3940] 445 463
[18]	[70] 10 668	[300] 35 665	[770] 85 657	[1240] 140 646	[1700] 190 630	[2140] 240 611	[2580] 290 609	[3020] 340 574	[3460] 390 552	[3900] 440 529
[20]	[60] 5 742	[280] 30 739	[730] 80 731	[1180] 135 715	[1630] 185 703	[2090] 235 684	[2550] 290 662	[2980] 335 643	[3440] 390 619	[3830] 435 595
[22]	[40] 5 816	[260] 30 813	[720] 80 805	[1180] 135 794	[1620] 185 777	[2070] 235 758	[2500] 280 749	[2930] 330 712	[3360] 380 687	
[24]	[20] 1.0 890	[230] 30 887	[690] 80 879	[1140] 130 868	[1540] 175 852	[2020] 230 834	[2460] 280 814	[2900] 330 782	[3340] 375 754	
[25]		[220] 25 924	[670] 75 916	[1120] 125 905	[1560] 175 890	[1990] 225 873	[2450] 275 846	[2890] 325 817		

Flow LPM [GPM]

C-1

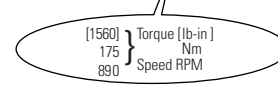

130cm<sup>3</sup>/r [8.0 in<sup>3</sup>/r]  
ΔPressure Bar [PSI]





	[250] 15	[500] 35	[1000] 70	[1500] 105	[2000] 140	[2500] 170	[3000] 205	[3500] 240	[4000] 275	[4500] 310
[.25]	[170] 20 3									
[.5]	[190] 20 12	[410] 45 8	[870] 100 2							
[1]	[230] 25 28	[510] 60 27	[1070] 120 23	[1580] 180 19	[2050] 230 16	[2520] 285 13	[2920] 309 9	[3310] 375 3		
[2]	[230] 25 56	[510] 60 56	[1080] 120 53	[1600] 180 47	[2090] 235 42	[2580] 290 39	[2930] 330 36	[3320] 375 28	[3640] 410 21	[3990] 450 13
[4]	[220] 25 114	[500] 55 113	[1080] 120 111	[1620] 185 104	[2150] 245 97	[2660] 300 95	[3100] 350 92	[3540] 400 85	[3980] 450 77	[4420] 500 70
[6]	[220] 25 172	[490] 55 171	[1080] 120 169	[1640] 185 161	[2190] 245 153	[2740] 310 149	[3260] 370 146	[3770] 425 132	[4280] 485 118	[4800] 540 104
[8]	[200] 25 230	[480] 55 224	[1080] 120 222	[1650] 185 219	[2220] 250 210	[2780] 315 204	[3310] 375 201	[3840] 435 192	[4360] 495 184	[4890] 550 175
[10]	[180] 20 287	[470] 55 286	[1070] 120 282	[1650] 185 276	[2230] 250 269	[2800] 315 261	[3420] 385 255	[3940] 445 243	[4450] 505 231	[4970] 560 219
[12]	[160] 20 345	[460] 50 344	[1060] 120 338	[1640] 185 333	[2230] 250 327	[2800] 315 317	[3350] 380 307	[3910] 440 295	[4440] 500 284	[4960] 560 272
[14]	[150] 15 403	[440] 50 402	[1030] 115 395	[1620] 185 391	[2220] 250 385	[3000] 340 373	[3350] 380 360	[3910] 440 348	[4440] 500 336	
[16]	[130] 15 461	[420] 45 460	[1010] 115 452	[1600] 180 447	[2200] 250 443	[2780] 315 430	[3330] 375 411	[3890] 440 397	[4440] 500 384	
[18]	[110] 10 518	[400] 45 517	[990] 110 509	[1580] 180 504	[2160] 245 500	[2750] 310 484	[3300] 375 471	[3860] 435 456	[4410] 500 440	
[20]	[90] 10 576	[380] 45 575	[960] 110 568	[1550] 175 560	[2130] 240 551	[2710] 305 539	[3280] 370 524	[3840] 435 508		
[22]	[60] 5 634	[350] 40 633	[940] 105 624	[1520] 170 619	[2100] 235 604	[2680] 305 597	[3250] 365 579	[3820] 430 560		
[24]	[40] 5 692	[325] 35 691	[920] 105 682	[1490] 170 676	[2070] 235 665	[2650] 300 651	[3220] 365 633	[3780] 425 616		
[25]	[20] 1.0 720	[310] 35 719	[900] 100 712	[1480] 165 705	[2050] 230 692	[2630] 295 679	[3200] 360 682	[3700] 420 656		

# 2000 Series

## Performance Data

Motors run with high efficiency in all areas designated with a number for torque and speed. For best motor life select a motor to run with a torque and speed range shown in the light shaded area.

Performance data is typical at 120 SUS. Actual data may vary slightly from unit to unit in production.

	Continuous		Peak
	Intermittent		No Operation

160cm<sup>3</sup>/r [9.6 in<sup>3</sup>/r]  
ΔPressure Bar [PSI]

[250]	[500]	[1000]	[1500]	[2000]	[2500]	[3000]	[3500]	[3750]
15	35	70	105	140	170	205	240	260

[.25]	[200]																			
0,95	25																			
[.5]	[240]	[490]	[990]	[1570]	[2140]															
1,9	25	55	110	175	240															
[1]	[280]	[590]	[1170]	[1730]	[2290]	[2830]	[3330]	[3820]	[4070]											
3,8	30	65	130	195	260	320	375	430	460											
[2]	[300]	[610]	[1210]	[1790]	[2350]	[2920]	[3480]	[4050]	[4330]											
7,5	35	70	135	200	265	330	395	460	490											
[4]	[320]	[630]	[1260]	[1890]	[2530]	[3170]	[3820]	[4460]	[4780]											
15	35	70	140	215	285	360	430	505	540											
[6]	[320]	[650]	[1300]	[1960]	[2620]	[3280]	[3940]	[4600]	[4930]											
23	35	75	145	220	295	370	445	520	560											
[8]	[310]	[650]	[1330]	[2010]	[2670]	[3330]	[4000]	[4660]	[4990]											
30	35	75	150	225	300	375	450	525	565											
[10]	[290]	[640]	[1340]	[2030]	[2690]	[3350]	[4020]	[4680]	[5010]											
38	35	70	150	230	305	380	455	530	570											
[12]	[270]	[620]	[1320]	[2020]	[2680]	[3340]	[4010]	[4670]	[5000]											
45	30	70	150	230	305	380	455	530	570											
[14]	[240]	[590]	[1300]	[2020]	[2690]	[3360]	[4030]	[4690]	[5020]											
53	25	65	145	230	305	380	455	530	570											
[16]	[220]	[570]	[1300]	[2020]	[2690]	[3330]	[4010]	[4680]	[5010]											
61	25	65	145	225	300	375	450	525	565											
[18]	[190]	[540]	[1240]	[1960]	[2640]	[3320]	[3990]													
68	20	60	140	220	300	375	450													
[20]	[170]	[510]	[1210]	[1920]	[2630]	[3310]	[3940]													
76	20	60	135	215	300	375	445													
[22]	[150]	[480]	[1170]	[1880]	[2600]	[3290]	[3920]													
83	15	55	130	210	295	370	445													
[24]	[120]	[450]	[1150]	[1860]	[2570]	[3260]	[3900]													
91	15	50	130	210	290	370	440													
[25]	[90]	[440]	[1140]	[1840]	[2560]	[3250]	[3880]													
95	10	50	130	210	290	375	440													
[30]	[330]	[1040]	[1750]	[2470]	[3140]	[3800]														
114	35	120	200	280	355	430														

{ 330 } Torque [lb-in]  
35 Nm  
713 Speed RPM

195cm<sup>3</sup>/r [11.9 in<sup>3</sup>/r]  
ΔPressure Bar [PSI]

[250]	[500]	[750]	[1000]	[1250]	[1500]	[1750]	[2000]	[2250]	[2500]	[2750]	[3000]	[3250]	[3500]	[3750]
15	35	50	70	85	105	120	140	155	170	190	205	225	240	260

[.25]	[240]	[590]																		
.95	25	65																		
[.5]	[290]	[640]	[990]	[1340]																
1,9	35	70	110	150																
[1]	[380]	[730]	[1100]	[1430]	[1790]	[2120]	[2450]	[2720]	[2990]	[3260]	[3540]	[3810]	[4080]	[4350]	[4620]					
3,8	45	80	125	160	200	275	340	400	475	540	610	680	750	820	890					
[2]	[390]	[755]	[1135]	[1470]	[1860]	[2195]	[2535]	[2880]	[3120]	[3680]	[4090]	[4500]	[4800]	[5100]	[5400]					
7,5	45	85	130	165	210	285	325	355	415	460	510	540	575	610	650					
[4]	[405]	[795]	[1185]	[1540]	[1970]	[2310]	[2675]	[3040]	[3420]	[3790]	[4180]	[4520]	[4890]	[5260]	[5630]					
15	45	90	135	175	225	260	300	345	385	430	470	510	550	595	635					
[6]	[405]	[815]	[1220]	[1590]	[2035]	[2395]	[2780]	[3170]	[3560]	[3940]	[4320]	[4700]	[5070]	[5450]	[5830]					
23	45	90	140	180	230	270	315	360	400	445	490	530	570	615	660					
[8]	[400]	[820]	[1230]	[1625]	[2065]	[2450]	[2850]	[3260]	[3670]	[4040]	[4410]	[4780]	[5150]	[5520]	[5890]					
30	45	90	140	185	235	275	320	370	415	455	500	540	580	625	665					
[10]	[380]	[810]	[1230]	[1645]	[2095]	[2480]	[2895]	[3310]	[3730]	[4100]	[4470]	[4840]	[5210]	[5590]						
38	45	95	140	185	235	280	325	375	420	465	505	545	590	630	160					
[12]	[355]	[790]	[1215]	[1650]	[2100]	[2485]	[2915]	[3340]	[3760]	[4120]	[4480]	[4850]								
45	40	90	135	185	235	280	330	375	425	465	505	550								
[14]	[320]	[765]	[1190]	[1645]	[2090]	[2475]	[2915]	[3350]	[3770]	[4130]	[4480]	[4860]								
53	35	85	135	185	235	280	330	380	425	465	505	550								
[16]	[290]	[730]	[1160]	[1625]	[2070]	[2455]	[2900]	[3340]	[3760]	[4130]	[4490]	[4860]								
61	30	80	130	185	235	275	330	375	425	465	505	550								
[18]	[290]	[690]	[1120]	[1590]	[2035]	[2420]	[2870]	[3310]	[3730]	[4100]	[4480]									
68	30	80	125	180	230	270	325	375	420	465	505									
[20]	[210]	[650]	[1080]	[1550]	[1995]	[2380]	[2830]	[3270]	[3690]	[4070]	[4450]									
76	25	75	120	175	225	270	320	370	415	460	500									
[22]	[170]	[610]	[1040]	[1500]	[1955]	[2340]	[2785]	[3220]	[3640]	[4050]										
83	20	70	120	170	220	265	315	365	410	460										
[24]	[135]	[570]	[1000]	[1440]	[1910]	[2300]	[2750]	[3190]	[3610]	[4020]										
91	15	65	115	165	215	260	310	360	405	450										
[25]	[120]	[550]	[980]	[1410]	[1890]	[2280]	[2730]	[3170]	[3590]	[3960]										
95	15	60	110	160	210	260	310	360	405	445										
[30]	[420]	[860]	[1290]	[1700]	[2120]	[2530]	[2940]	[3400]												
114	45	95	145	190	240	285	330	385												

# 2000 Series

## Performance Data

Motors run with high efficiency in all areas designated with a number for torque and speed. For best motor life select a motor to run with a torque and speed range shown in the light shaded area.

Performance data is typical at 120 SUS. Actual data may vary slightly from unit to unit in production.

	Continuous		Peak
	Intermittent		No Operation

**245cm<sup>3</sup>/r [14.9 in<sup>3</sup>/r]**  
**ΔPressure Bar [PSI]**

	[250]	[500]	[750]	[1000]	[1250]	[1500]	[1750]	[2000]	[2250]	[2500]	[2750]	[3000]	[3250]	[3500]	[3750]
	15	35	50	70	85	105	120	140	155	170	190	205	225	240	260
[.5]	[410]	[850]													
1.9	45 4	95 2													
[1]	[450]	[930]	[1420]	[1850]	[2320]	[2780]	[3250]	[3650]	[4100]	[4540]	[4980]	[5430]	[5870]	[6310]	
3.8	50 14	105 13	160 12	210 11	260 10	315 9	365 8	410 6	465 5	515 4	560 4	615 3	665 2	715 1	
[2]	[460]	[960]	[1460]	[1900]	[2400]	[2860]	[3340]	[3780]	[4320]	[4770]	[5210]	[5660]	[6110]	[6570]	[6950]
7.5	50 29	110 28	165 27	215 26	270 25	325 23	375 22	425 20	490 19	540 18	590 17	640 15	690 14	740 12	785 10
[4]	[470]	[1000]	[1540]	[1980]	[2510]	[3010]	[3480]	[3980]	[4450]	[4910]	[5380]	[5850]	[6320]	[6780]	[7250]
15	55 60	115 59	175 58	225 56	285 54	340 53	395 51	450 49	505 48	555 47	605 47	660 46	715 45	765 44	820 42
[6]	[460]	[1020]	[1550]	[2040]	[2580]	[3110]	[3590]	[4120]	[4580]	[5050]	[5520]	[5980]	[6440]	[6910]	
23	50 91	115 90	175 89	230 87	290 84	350 83	405 81	465 78	515 76	570 73	625 71	675 69	730 67	780 65	
[8]	[460]	[1010]	[1560]	[2080]	[2630]	[3170]	[3670]	[4210]	[4680]	[5160]	[5630]	[6100]	[6590]		
30	50 122	115 121	175 120	235 118	295 115	360 113	415 111	475 108	530 106	585 104	635 102	690 101	745 99		
[10]	[440]	[1000]	[1550]	[2110]	[2650]	[3200]	[3730]	[4250]	[4730]	[5210]	[5700]	[6200]			
38	50 153	115 152	175 150	240 148	300 146	360 144	420 142	480 139	535 137	590 135	645 133	705 131			
[12]	[410]	[960]	[1530]	[2100]	[2640]	[3190]	[3760]	[4260]	[4740]	[5220]	[5730]				
45	45 184	110 183	175 182	235 180	300 177	360 175	425 173	480 170	535 168	590 165	645 162				
[14]	[380]	[910]	[1500]	[2080]	[2600]	[3160]	[3760]	[4230]	[4710]	[5190]					
53	40 215	105 214	170 213	235 211	295 209	355 207	425 204	480 201	530 198	585 195					
[16]	[340]	[860]	[1460]	[2040]	[2570]	[3120]	[3740]	[4180]	[4660]	[5140]					
61	40 246	95 245	165 244	230 242	290 240	355 238	425 235	470 232	525 227	580 223					
[18]	[290]	[810]	[1420]	[2000]	[2520]	[3060]	[3700]	[4130]	[4610]	[5090]					
68	30 277	90 276	160 275	225 273	285 271	345 269	420 266	465 263	520 258	575 253					
[20]	[250]	[800]	[1350]	[1910]	[2460]	[3010]	[3630]	[4110]	[4610]						
76	30 308	80 306	155 304	215 302	280 300	340 298	410 295	465 291	520 288						
[22]	[200]	[710]	[1300]	[1870]	[2390]	[2940]	[3560]	[4010]	[4510]						
83	25 339	80 337	145 337	210 334	270 332	330 330	400 327	455 323	510 318						
[24]	[150]	[670]	[1240]	[1790]	[2330]	[2880]	[3460]	[3960]	[4460]						
91	15 370	75 369	140 367	200 364	265 362	325 360	390 357	445 353	505 344						
[25]	[120]	[660]	[1210]	[1750]	[2300]	[2860]	[3410]	[3950]	[4470]						
95	15 385	75 384	135 382	200 379	260 377	325 375	385 372	445 367	505 363						
[30]		[520]	[1080]	[1620]	[2180]	[2720]	[3260]	[3790]							
114		60 462	120 460	185 458	245 455	305 453	370 450	430 447							

**305cm<sup>3</sup>/r [18.7 in<sup>3</sup>/r]**  
**ΔPressure Bar [PSI]**

	[250]	[500]	[750]	[1000]	[1250]	[1500]	[1750]	[2000]	[2250]	[2500]	[2750]	[3000]	[3250]	[3500]
	15	35	50	70	85	105	120	140	155	170	190	205	225	240
[.5]	[500]	[1050]												
1.9	55 4	120 2												
[1]	[610]	[1180]	[1750]	[2330]	[2870]	[3440]	[3930]	[4410]	[4900]	[5380]				
3.8	70 12	135 11	200 11	260 10	325 10	390 9	445 8	500 6	555 3	610 1				
[2]	[620]	[1210]	[1800]	[2400]	[2970]	[3510]	[4050]	[4600]	[5140]	[5680]	[6220]	[6750]	[7290]	[7820]
7.5	70 24	135 24	205 23	270 22	335 22	395 20	460 19	520 18	580 17	640 15	705 13	765 11	825 8	885 6
[4]	[680]	[1250]	[1880]	[2500]	[3120]	[3690]	[4260]	[4840]	[5410]	[5980]	[6550]	[7120]	[7690]	
15	75 49	140 49	210 48	280 47	355 47	415 45	480 43	545 42	610 40	675 38	740 36	805 34	870 33	
[6]	[620]	[1270]	[1920]	[2560]	[3230]	[3810]	[4390]	[4970]	[5550]	[6130]	[6710]	[7290]		
23	70 74	145 74	215 72	290 72	365 71	430 69	495 66	560 64	630 61	695 58	760 55	825 52		
[8]	[600]	[1270]	[1940]	[2600]	[3290]	[3880]	[4470]	[5070]	[5660]	[6250]	[6840]			
30	70 98	145 98	220 97	295 96	370 95	440 93	505 90	575 86	640 83	705 80	775 77			
[10]	[570]	[1250]	[1940]	[2610]	[3310]	[3920]	[4530]	[5150]	[5760]	[6370]				
38	65 123	140 122	220 121	295 120	375 119	440 117	510 113	580 110	650 106	720 102				
[12]	[530]	[1220]	[1920]	[2600]	[3300]	[3920]	[4530]	[5150]	[5760]	[6370]				
45	60 148	140 147	215 145	295 144	375 143	440 142	510 138	580 133	650 128	720 124				
[14]	[480]	[1180]	[1870]	[2560]	[3260]	[3900]	[4510]	[5120]	[5730]					
53	55 172	135 172	210 170	290 168	370 167	440 165	510 160	580 156	645 152					
[16]	[430]	[1120]	[1820]	[2500]	[3210]	[3870]	[4480]	[5080]	[5690]					
61	50 196	125 196	205 194	280 192	365 191	440 188	505 183	575 178	645 174					
[18]	[370]	[1060]	[1760]	[2440]	[3140]	[3800]	[4420]	[5050]						
68	40 221	120 221	200 218	275 217	355 215	440 212	500 207	570 202						
[20]	[320]	[980]	[1680]	[2360]	[3050]	[3710]	[4370]	[5020]						
76	35 246	110 245	190 243	265 241	345 239	420 236	495 231	565 226						
[22]	[240]	[920]	[1620]	[2300]	[2990]	[3560]	[4190]	[4820]						
83	25 271	105 270	185 268	260 266	340 263	400 260	475 258	545 255						
[24]	[180]	[870]	[1550]	[2240]	[2920]	[3420]	[4020]	[4630]						
91	20 296	100 294	175 293	255 290	330 288	385 285	455 283	525 280						
[25]	[150]	[840]	[1520]	[2200]	[2890]	[3340]	[3930]	[4520]						
95	15 308	95 307	170 305	250 303	325 302	375 298	445 295	510 293						
[30]		[680]	[1360]	[2040]	[2720]	[3140]	[3810]							
114		75 365	155 362	230 360	305 357	355 356	430 352							

[3790] } Torque [lb-in]  
 430 } Nm  
 447 } Speed RPM

# 2000 Series

## Performance Data

Motors run with high efficiency in all areas designated with a number for torque and speed. For best motor life select a motor to run with a torque and speed range shown in the light shaded area.

Performance data is typical at 120 SUS. Actual data may vary slightly from unit to unit in production.

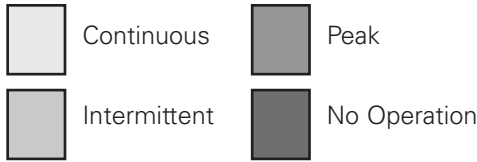

**490cm<sup>3</sup>/r [29.8 in<sup>3</sup>/r]**  
ΔPressure Bar [PSI]

	[250]	[500]	[750]	[1000]	[1250]	[1500]	[1750]	[2000]
	15	35	50	70	85	105	120	140
[.5]	[670]	[1600]						
1.9	75 2	180 1						
[1]	[920]	[2000]	[2990]	[3900]	[4880]			
3.8	105 7	225 6	340 5	440 4	550 2			
[2]	[950]	[2060]	[3110]	[4080]	[5110]	[6320]		
7.5	105 14	235 13	350 12	460 10	575 9	715 7		
[4]	[980]	[2130]	[3230]	[4270]	[5350]	[6370]	[7380]	[7980]
15	110 30	240 29	365 28	480 27	605 26	720 24	835 22	900 20
[6]	[980]	[2120]	[3230]	[4300]	[5370]	[6420]	[7470]	[8225]
23	110 45	240 44	365 43	485 42	605 41	725 39	845 37	930 35
[8]	[980]	[2110]	[3220]	[4330]	[5400]	[6470]	[7550]	
30	110 61	240 60	365 59	490 58	610 57	730 55	855 52	
[10]	[920]	[2050]	[3170]	[4300]	[5390]	[6460]	[7550]	
38	105 76	230 75	360 74	485 73	610 72	730 70	855 68	
[12]	[860]	[1990]	[3120]	[4260]	[5370]	[6460]	[7560]	
45	95 91	225 90	355 90	480 89	605 87	730 85	855 84	
[14]	[790]	[1930]	[3055]	[4185]	[5300]	[6400]		
53	90 106	220 105	345 105	475 104	600 102	725 100		
[16]	[720]	[1870]	[2990]	[4110]	[5230]	[6340]		
61	80 122	210 121	340 120	465 119	590 118	715 116		
[18]	[630]	[1770]	[2890]	[4020]	[5140]	[6260]		
68	70 137	200 136	325 135	455 134	580 133	705 131		
[20]	[550]	[1670]	[2800]	[3940]	[5060]	[6180]		
76	60 153	190 152	315 151	445 150	570 149	700 146		
[22]	[450]	[1570]	[2700]	[3830]	[4960]	[6070]		
83	50 168	175 168	305 167	435 165	560 164	685 161		
[24]	[360]	[1480]	[2600]	[3730]	[4860]	[5970]		
91	40 184	165 184	295 183	420 181	550 179	675 177		
[26]	[270]	[1390]	[2510]	[3640]	[4770]			
98	30 199	155 195	285 194	410 192	540 190			
[28]		[1260]	[2370]	[3520]	[4630]			
106		140 212	270 211	400 209	525 207			
[30]		[1130]	[2240]	[3400]	[4500]			
114		125 230	255 229	385 227	510 224			

**395cm<sup>3</sup>/r [24.0 in<sup>3</sup>/r]**  
ΔPressure Bar [PSI]

	[250]	[500]	[750]	[1000]	[1250]	[1500]	[1750]	[2000]	[2250]	[2500]	[2750]
	15	35	50	70	85	105	120	140	155	170	190
[.5]	[560]	[1310]									
1.9	65 4	150 3									
[1]	[770]	[1540]	[2290]	[3080]	[3780]	[4480]	[5170]	[5880]	[6580]	[7270]	[7980]
3.8	85 9	175 9	260 9	350 8	430 8	505 7	585 7	665 6	745 5	820 4	900 3
[2]	[790]	[1580]	[2360]	[3180]	[3930]	[4680]	[5430]	[6180]	[6940]	[7700]	[8470]
7.5	90 18	180 18	265 18	360 17	445 17	530 16	615 15	700 14	775 13	845 11	925 10
[4]	[810]	[1660]	[2480]	[3320]	[4130]	[4940]	[5740]	[6550]	[7330]	[8100]	
15	90 37	190 37	280 37	375 36	465 36	560 35	650 34	740 33	815 31	890 28	
[6]	[820]	[1700]	[2550]	[3420]	[4250]	[5080]	[5920]	[6750]	[7580]	[8400]	
23	90 57	190 56	290 56	385 55	480 55	575 54	670 52	765 49	840 47	905 45	
[8]	[820]	[1700]	[2580]	[3460]	[4300]	[5130]	[5960]	[6800]			
30	90 76	190 75	290 75	390 74	485 73	580 71	675 69	770 68			
[10]	[800]	[1700]	[2590]	[3480]	[4320]	[5160]	[6000]	[6840]			
38	90 95	190 94	295 94	395 93	490 92	585 90	680 88	775 86			
[12]	[770]	[1680]	[2570]	[3470]	[4310]	[5150]	[5990]	[6830]			
45	85 114	190 113	290 113	390 112	485 111	580 109	675 106	770 103			
[14]	[740]	[1640]	[2530]	[3430]	[4280]	[5120]	[5960]				
53	85 133	185 132	285 132	390 131	485 129	580 127	675 124				
[16]	[690]	[1590]	[2480]	[3370]	[4220]	[5060]	[5910]				
61	80 153	180 152	280 152	380 150	475 149	570 146	670 144				
[18]	[640]	[1530]	[2420]	[3310]	[4160]	[5010]	[5870]				
68	70 172	170 171	275 171	375 170	470 169	565 167	665 164				
[20]	[580]	[1470]	[2370]	[3260]	[4110]	[4960]	[5820]				
76	65 191	165 190	270 190	370 189	465 188	560 186	660 184				
[22]	[510]	[1390]	[2290]	[3170]	[4030]	[4880]					
83	60 210	155 209	260 209	360 208	455 207	550 206					
[24]	[440]	[1330]	[2220]	[3100]	[3950]	[4800]					
91	50 230	150 229	250 228	350 227	445 225	540 224					
[26]	[350]	[1240]	[2130]	[3020]	[3880]	[4730]					
98	40 249	140 248	240 247	340 246	440 244	535 242					
[28]	[270]	[1150]	[2050]	[2930]	[3790]	[4650]					
106	30 268	130 267	230 265	330 264	430 261	525 259					
[30]	[180]	[1060]	[1960]	[2850]	[3710]	[4570]					
114	20 287	120 286	220 284	320 283	420 281	515 277					
[35]		[840]	[1760]	[2640]	[3480]						
132		95 335	200 334	300 333	395 332						

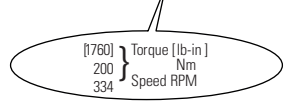

# 2000 Series

## Dimensions

### Standard Mount

## Ports

- 7/8 -14 UNF-2B SAE O-ring Staggered Ports (2)
- 7/16 -20 UNF-2B SAE O-ring Case Drain Port (1) or
- 1 1/16 -12 UN-2B SAE O-ring Ports (Positioned 180° Apart) (2)
- 7/16 -20 UNF-2B SAE O-ring Case Drain Port (1) or
- 7/8 -14 UNF-2B SAE O-ring End Ports (2)
- 7/16 -20 UNF-2B SAE O-ring Case Drain Port (1) or
- G 1/2 (BSP) Staggered Ports (2)
- G 1/4 (BSP) Case Drain Port (1) or
- Manifold Mount
- 7/16 -20 UNF-2B SAE O-ring Case Drain Port (1)

## Standard Rotation Viewed from Shaft End

- Port A Pressurized — CW
- Port B Pressurized — CCW

## Standard Mount

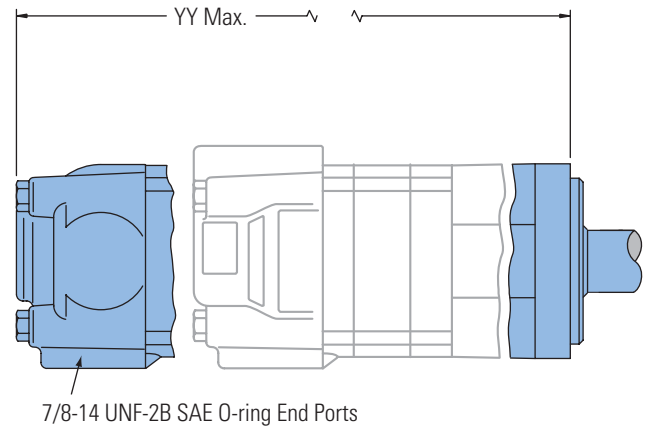
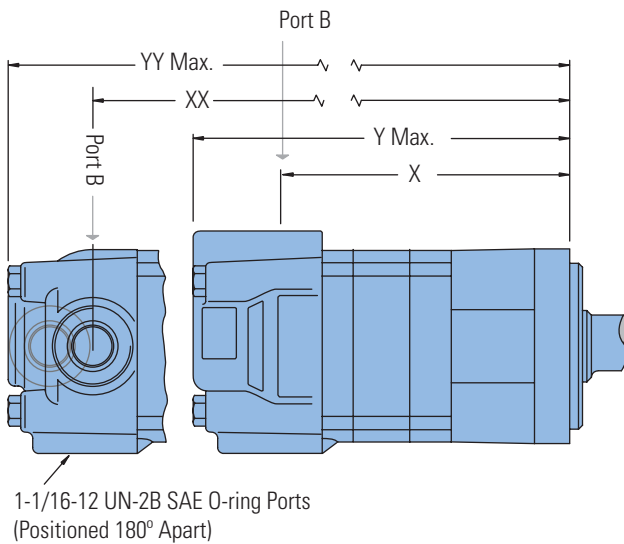

C-1

### STANDARD MOUNT MOTOR DIMENSIONS

Displacement cm <sup>3</sup> /r [in <sup>3</sup> /r]	X mm [inch]	Y mm [inch]	XX mm [inch]	YY mm [inch]
34 [2.1]	126,7 [4.99]	174,0 [6.85]	129,0 [5.08]	175,3 [6.90]
41 [2.5]	128,0 [5.04]	175,3 [6.90]	130,5 [5.14]	176,8 [6.96]
66 [4.0]	133,9 [5.27]	181,1 [7.13]	136,1 [5.36]	182,4 [7.18]
80 [4.9]	136,9 [5.39]	184,2 [7.25]	139,2 [5.48]	185,4 [7.30]
100 [6.2]	141,5 [5.57]	189,0 [7.44]	143,8 [5.66]	190,3 [7.49]
130 [8.0]	147,9 [5.83]	195,4 [7.69]	150,2 [5.92]	196,6 [7.74]
160 [9.6]	147,9 [5.83]	195,4 [7.69]	150,2 [5.92]	196,6 [7.74]
195 [11.9]	154,7 [6.09]	202,2 [7.96]	157,0 [6.18]	203,2 [8.00]
245 [14.9]	163,7 [6.45]	211,1 [8.31]	166,0 [6.54]	212,4 [8.36]
305 [18.7]	175,1 [6.90]	222,3 [8.75]	177,4 [6.99]	223,5 [8.80]
395 [24.0]	191,0 [7.52]	238,6 [9.39]	193,3 [7.61]	239,8 [9.44]
490 [29.8]	208,4 [8.21]	255,8 [10.07]	210,7 [8.30]	270,1 [10.12]

# 2000 Series

## Dimensions

Standard Mount with  
Integral Relief Valve

## Ports

7/8 -14 UNF-2B SAE O-ring Staggered Ports (2)  
7/16 -20 UNF-2B SAE O-ring Case Drain Port (1) or  
G 1/2 (BSP) Staggered Ports (2)  
G 1/4 (BSP) Case Drain Port (1)

## Standard Rotation Viewed from Shaft End

Port A Pressurized — CW  
Port B Pressurized — CCW

## Standard Mount with Integral Relief Valve

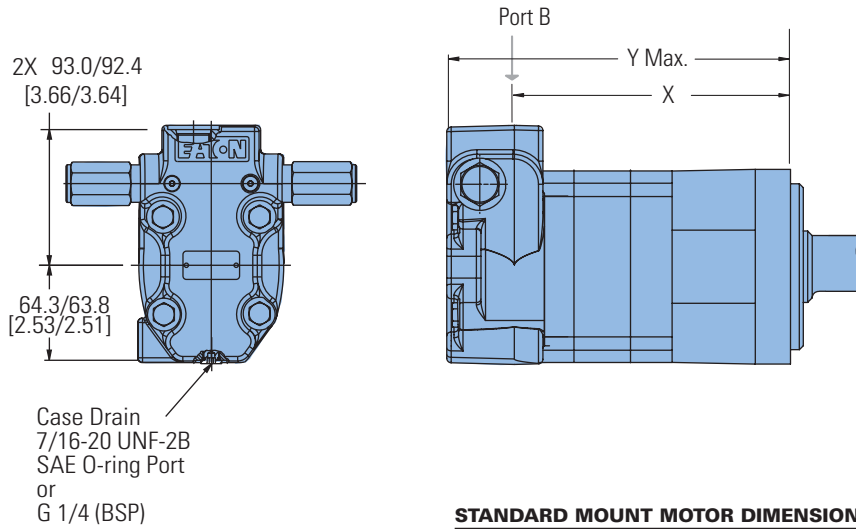

## STANDARD MOUNT MOTOR DIMENSIONS

Displacement cm <sup>3</sup> /r [in <sup>3</sup> /r]	X mm [inch]	Y mm [inch]
34 [2.1]	126,7 [4.99]	174,0 [6.85]
41 [2.5]	128,2 [5.05]	175,5 [6.91]
66 [4.0]	133,9 [5.27]	181,2 [7.13]
80 [4.9]	137,0 [5.40]	184,5 [7.26]
100 [6.2]	141,6 [5.58]	189,0 [7.44]
130 [8.0]	147,9 [5.83]	195,4 [7.69]
160 [9.6]	147,9 [5.83]	195,4 [7.69]
195 [11.9]	154,8 [6.10]	202,2 [7.96]
245 [14.9]	163,7 [6.45]	211,1 [8.31]
305 [18.7]	175,1 [6.90]	222,6 [8.76]
395 [24.0]	191,1 [7.53]	238,6 [9.39]
490 [29.8]	208,4 [8.21]	255,8 [10.07]

# 2000 Series

Dimensions

Wheel Mount

## Ports

- 7/8 -14 UNF-2B SAE O-ring Staggered Ports (2)
- 7/16 -20 UNF-2B SAE O-ring Case Drain Port (1) or
- 1 1/16 -12 UN-2B SAE O-ring Ports (Positioned 180° Apart) (2)
- 7/16 -20 UNF-2B SAE O-ring Case Drain Port (1) or
- 7/8 -14 UNF-2B SAE O-ring End Ports (2)
- 7/16 -20 UNF-2B SAE O-ring Case Drain Port (1) or
- G 1/2 (BSP) Staggered Ports (2)
- G 1/4 (BSP) Case Drain Port (1) or
- Manifold Mount
- 7/16 -20 UNF-2B SAE O-ring Case Drain Port (1)

## Standard Rotation Viewed from Shaft End

- Port A Pressurized — CW
- Port B Pressurized — CCW

## Wheel Mount

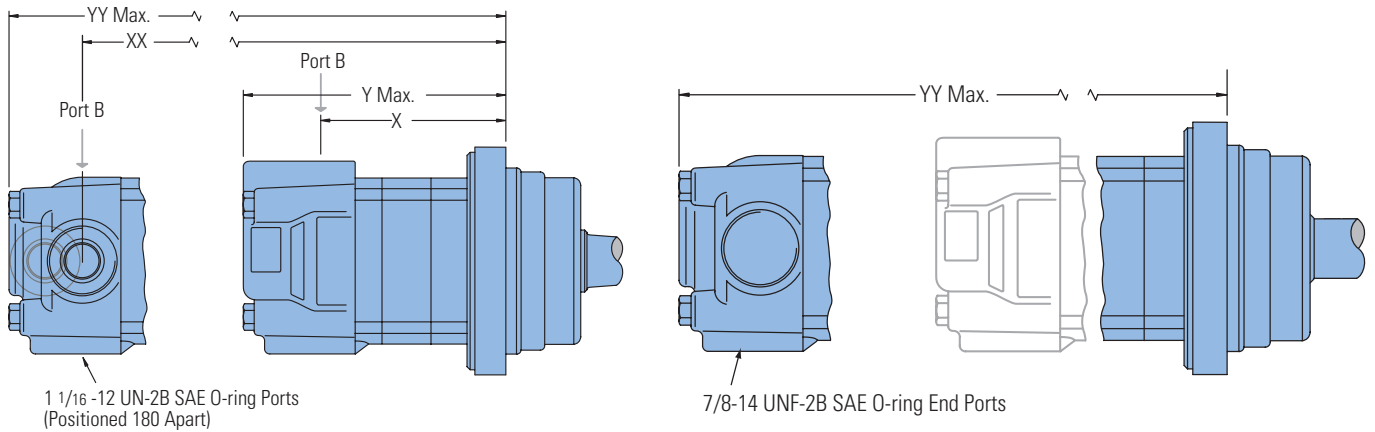

## WHEEL MOUNT MOTOR DIMENSIONS

Displacement	X	Y	XX	YY
cm <sup>3</sup> /r [in <sup>3</sup> /r]	mm [inch]	mm [inch]	mm [inch]	mm [inch]
34 [2.1]	86,5 [3.41]	133,8 [5.27]	88,8 [3.50]	135,1 [5.32]
41 [2.5]	88,0 [3.47]	135,3 [5.33]	90,3 [3.56]	136,6 [5.38]
66 [4.0]	93,7 [3.69]	141,0 [5.55]	96,0 [3.78]	142,3 [5.60]
80 [4.9]	96,8 [3.81]	144,0 [5.67]	99,1 [3.90]	145,3 [5.72]
100 [6.2]	101,3 [3.99]	148,9 [5.86]	103,6 [4.08]	150,2 [5.91]
130 [8.0]	107,8 [4.25]	155,2 [6.11]	110,1 [4.34]	156,5 [6.16]
160 [9.6]	107,8 [4.25]	155,2 [6.11]	110,1 [4.34]	156,5 [6.16]
195 [11.9]	114,6 [4.51]	161,8 [6.37]	116,8 [4.60]	163,1 [6.42]
245 [14.9]	123,5 [4.87]	171,0 [6.73]	125,8 [4.96]	172,3 [6.78]
305 [18.7]	135,0 [5.32]	182,1 [7.17]	137,4 [5.41]	183,4 [7.22]
395 [24.0]	150,9 [5.94]	198,4 [7.81]	153,2 [6.03]	199,7 [7.86]
490 [29.8]	168,2 [6.63]	215,7 [8.49]	170,7 [6.72]	217,0 [8.54]



# 2000 Series

## Dimensions

Wheel Mount with Integral Relief Valve

## Ports

7/8 -14 UNF-2B SAE O-ring Staggered Ports (2)  
 7/16 -20 UNF-2B SAE O-ring Case Drain Port (1)

G 1/2 (BSP) Staggered Ports (2)

G 1/4 (BSP) Case Drain Port (1)

## Standard Rotation Viewed from Shaft End

Port A Pressurized — CW

Port B Pressurized — CCW

## Wheel Mount with Integral Relief Valve

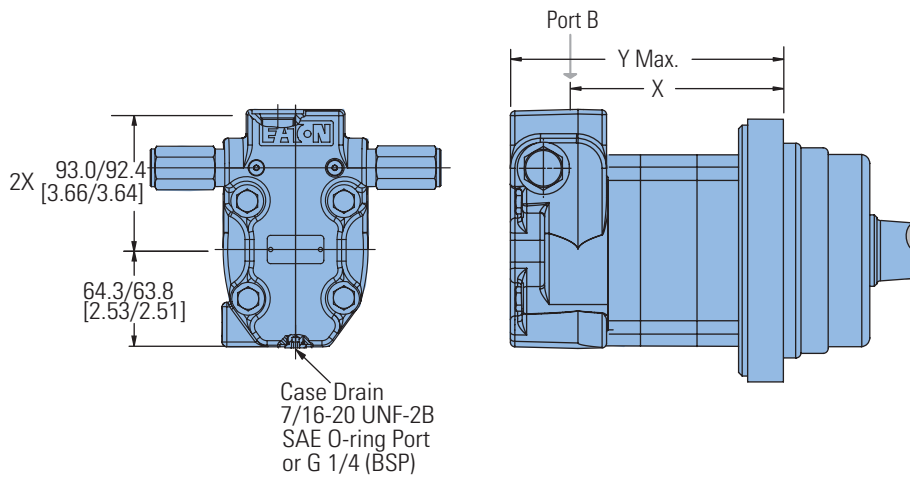

### WHEEL MOUNT MOTOR DIMENSIONS

Displacement cm <sup>3</sup> /r [in <sup>3</sup> /r]	X mm [inch]	Y mm [inch]
34 [2.1]	86,5 [3.41]	133,8 [5.27]
41 [2.5]	88,0 [3.47]	135,3 [5.33]
66 [4.0]	93,7 [3.69]	141,0 [5.55]
80 [4.9]	96,9 [3.82]	144,3 [5.68]
100 [6.2]	101,4 [4.00]	148,9 [5.86]
130 [8.0]	107,8 [4.25]	155,2 [6.11]
160 [9.6]	107,8 [4.25]	155,2 [6.11]
195 [11.9]	114,6 [4.52]	162,1 [6.38]
245 [14.9]	123,5 [4.87]	171,0 [6.73]
305 [18.7]	135,0 [5.32]	182,4 [7.18]
395 [24.0]	151,0 [5.95]	198,4 [7.81]
490 [29.8]	168,2 [6.63]	215,7 [8.49]

# 2000 Series

Dimensions

Bearingless

## Bearingless

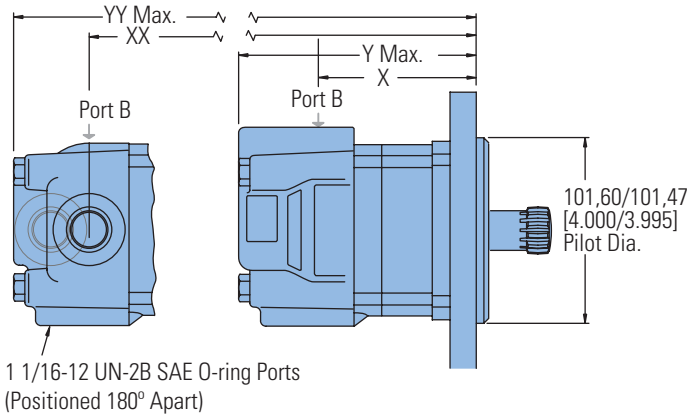

## Ports

- 7/8 -14 UNF-2B SAE O-ring Staggered Ports (2)
- 7/16 -20 UNF-2B SAE O-ring Case Drain Port (1) or
- 1 1/16 -12 UN-2B SAE O-ring Ports (Positioned 180° Apart) (2)
- 7/16 -20 UNF-2B SAE O-ring Case Drain Port (1) or
- 7/8 -14 UNF-2B SAE O-ring End Ports (2)
- 7/16 -20 UNF-2B SAE O-ring Case Drain Port (1) or
- G 1/2 (BSP) Staggered Ports (2)
- G 1/4 (BSP) Case Drain Port (1) or
- Manifold Mount
- 7/16 -20 UNF-2B SAE O-ring Case Drain Port (1)

## Standard Rotation Viewed from Shaft End

- Port A Pressurized — CW
- Port B Pressurized — CCW

### MAT'L

- C 35,86 [1.412] Dia.
- D 34,04 [1.340] Dia.
- E 81,0 [3.19] Min. Full Form Dia.
- F 86,1 [3.39] Max.
- G 62,10 [2.445] Full Form Dia.
- H 38,40 [1.512] Dia.
- J 43,7 [1.72] Dia.
- K 25,91 [1.020]
- L 8,25 [.325]
- M 0,89 [.035]
- N 15°

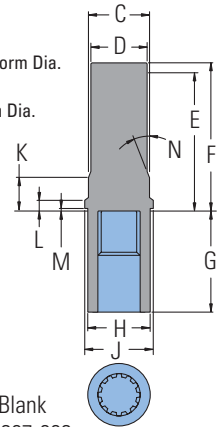

C-1

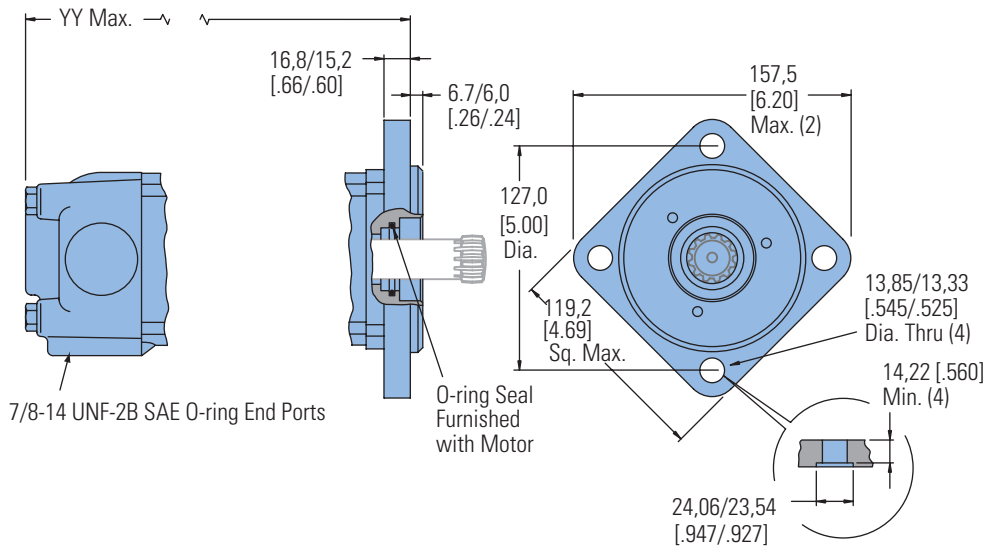

For 2000 Series Bearingless Motor application information contact your Eaton representative (mating coupling blanks available from Eaton Hydraulics).

### Note:

After machining blank, part must be hardened per Eaton specification.

### BEARINGLESS MOTOR DIMENSIONS

Displacement cm <sup>3</sup> /r [in <sup>3</sup> /r]	X mm [inch]	Y mm [inch]	XX mm [inch]	YY mm [inch]
34 [2.1]	68,7 [2.71]	116,3 [4.58]	70,9 [2.79]	117,6 [4.63]
41 [2.5]	70,1 [2.76]	117,6 [4.63]	72,4 [2.85]	119,1 [4.69]
66 [4.0]	75,7 [2.98]	123,4 [4.86]	78,1 [3.08]	124,8 [4.91]
80 [4.9]	79,0 [3.11]	126,5 [4.98]	81,3 [3.20]	127,8 [5.03]
100 [6.2]	83,5 [3.29]	131,4 [5.17]	85,8 [3.38]	132,6 [5.22]
130 [8.0]	89,9 [3.54]	137,7 [5.42]	92,2 [3.63]	139,0 [5.47]

### BEARINGLESS MOTOR DIMENSIONS

Displacement cm <sup>3</sup> /r [in <sup>3</sup> /r]	X mm [inch]	Y mm [inch]	XX mm [inch]	YY mm [inch]
160 [9.6]	89,9 [3.54]	137,7 [5.42]	92,2 [3.63]	139,0 [5.47]
195 [11.9]	96,8 [3.81]	144,3 [5.68]	99,0 [3.90]	145,5 [5.73]
245 [14.9]	105,6 [4.16]	153,5 [6.04]	107,9 [4.25]	154,7 [6.09]
305 [18.7]	117,1 [4.61]	164,6 [6.48]	119,4 [4.70]	165,9 [6.53]
395 [24.0]	133,1 [5.24]	180,9 [7.12]	135,4 [5.33]	182,1 [7.17]
490 [29.8]	150,3 [5.92]	198,2 [7.80]	152,7 [6.01]	199,3 [7.85]

# 2000 Series

## Dimensions

Bearingless with Integral Relief Valve

## Ports

7/8 -14 UNF-2B SAE O-ring Staggered Ports (2)  
 7/16 -20 UNF-2B SAE O-ring Case Drain Port (1)  
 G 1/2 (BSP) Staggered Ports (2)  
 G 1/4 (BSP) Case Drain Port (1)

## Standard Rotation Viewed from Shaft End

Port A Pressurized — CW  
 Port B Pressurized — CCW

## Bearingless with Integral Relief Valve

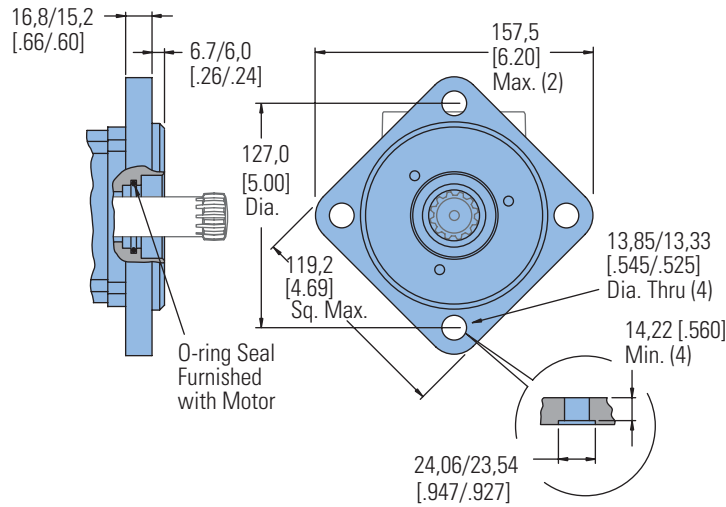
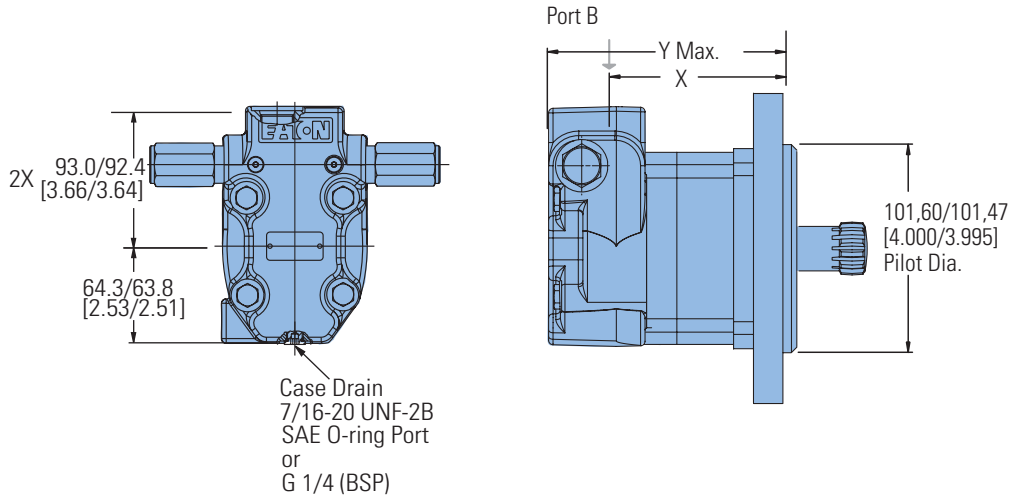

### BEARINGLESS MOTORS DIMENSIONS

Displacement cm <sup>3</sup> /r [in <sup>3</sup> /r]	X mm [inch]	Y mm [inch]
34 [2.1]	68,6 [2.70]	116,3 [4.58]
41 [2.5]	70,1 [2.76]	117,8 [4.64]
66 [4.0]	75,8 [2.99]	123,5 [4.86]
80 [4.9]	79,0 [3.11]	126,8 [4.99]
100 [6.2]	83,5 [3.29]	131,4 [5.17]
130 [8.0]	89,9 [3.54]	137,7 [5.42]

### BEARINGLESS MOTORS DIMENSIONS

Displacement cm <sup>3</sup> /r [in <sup>3</sup> /r]	X mm [inch]	Y mm [inch]
160 [9.6]	89,9 [3.54]	137,7 [5.42]
195 [11.9]	96,8 [3.81]	144,6 [5.69]
245 [14.9]	105,6 [4.16]	153,5 [6.04]
305 [18.7]	117,1 [4.61]	164,9 [6.49]
395 [24.0]	133,1 [5.24]	180,9 [7.12]
490 [29.8]	150,3 [5.92]	198,2 [7.80]

# 2000 Series

## Installation Information

- 1 Internal spline in mating part to be per spline data. Specification material to be ASTM A304, 8620H vacuum degassed alloy steel carbonize to a hardness of 59-62 HRC with case depth (to 50HRC) of 0,076 -1,02 [.030 -.040]. Dimensions apply after heat treat.
- 2 Mating part to have critical dimensions as shown. Oil holes must be provided and open for proper oil circulation.
- 3 Seal to be furnished with motor for proper oil circulation thru splines.
- 4 Some means of maintaining clearance between shaft and mounting flange must be provided.
- 5 Counterbore designed to adapt a standard sleeve bearing 35,010 -35,040 [1.3784 -1.3795] I.D. by 44,040 -44,070 [1.7339 -1.7350] O.D. (Oilite Bronze Sleeve Bearing AAM3544-22).

### Bearingless

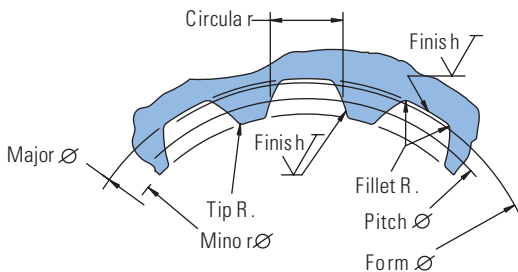
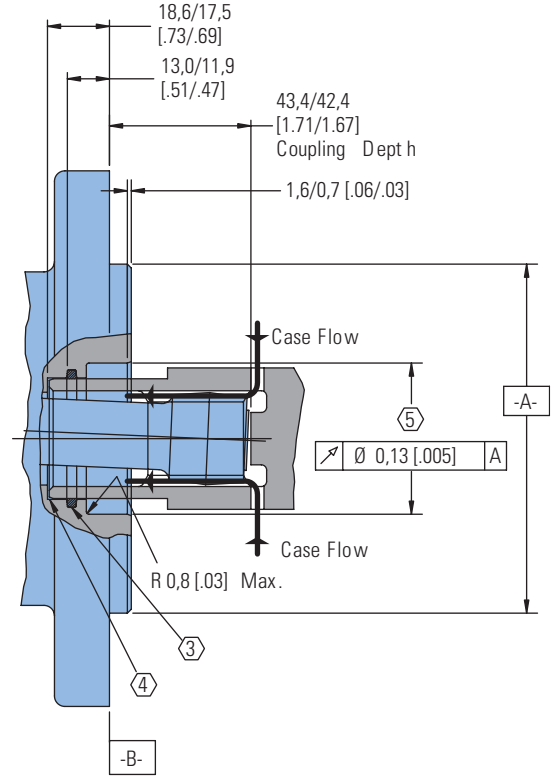
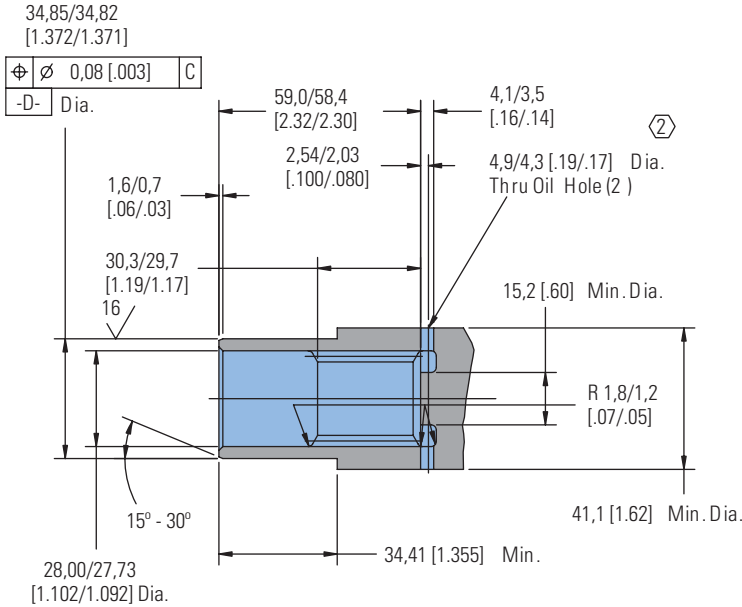

Spline Pitch.....	12/24
Pressure Angle.....	30°
Number of teeth.....	12
Class of Fit.....	Ref. 5
Type of Fit.....	Side
Side Pitch Diameter.....	Ref. 25,400000 [1.0000000]
Base Diameter.....	Ref. 21,997045 [.8660254] $\text{C} \text{ } 0,21 \text{ } [.008] \text{ }   \text{ } D$
Major Diameter.....	(27,74 [1.092] Max. 27,59 [1.086] Min.)
Minor Diameter.....	23,097 - 23,224 [.9093 - .9143]
Form Diameter, Min.....	29,93 [1.060]
Fillet Radius.....	0,64 - 0,76 [.025 - .030]
Tip Radius.....	0,25 - 0,38 [.010 - .015]
Finish.....	1,6 (63)
Involute Profile Variation.....	+0,000 -0,025 [+0.0000 -0.010]
Total Index Variation.....	0,038 [.0015]
Lead Variation.....	0,013 [.0005]
Circular Space Width:	
Maximum Actual.....	4,318 [1.700]
Minimum Effective.....	4,216 [1.660]
Maximum Effective.....	Ref. 4,270 [1.681]
Minimum Actual.....	Ref. 4,247 [1.672]
Dimension Between Two Pins.....	Ref. 19,020 - 19,190 [.7488 - .7555]
Pin Diameter.....	4,496 [1.770] Pins to Have 3,38 [1.133]
	Wide Flat for Root Clearance

# 2000 Series

Dimensions

Mounting Options

## Mounting Code : AC

### SAE A – Two Bolt (Standard Motor)

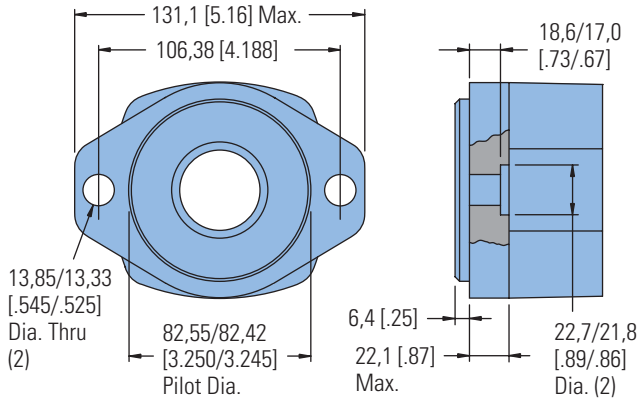

## Mounting Code: AF

### SAE B – Two Bolt

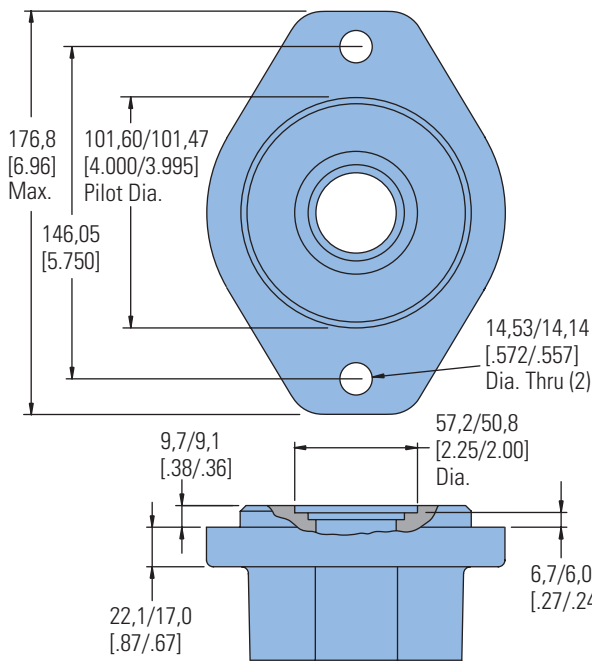

## Mounting Code: BY

### Four Bolt (Standard Motor)

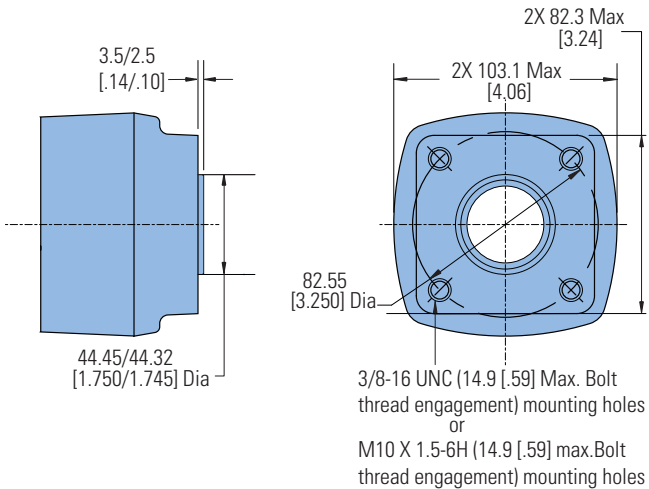

## Mounting Code : AH

### Four Bolt

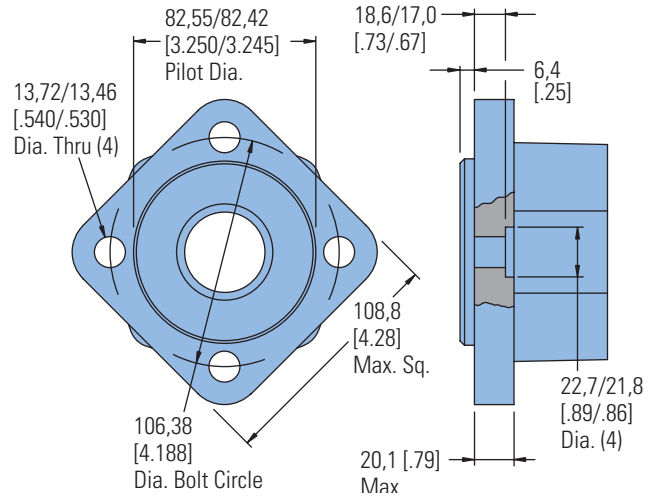

## Mounting Code : AJ

### Four Bolt Magneto

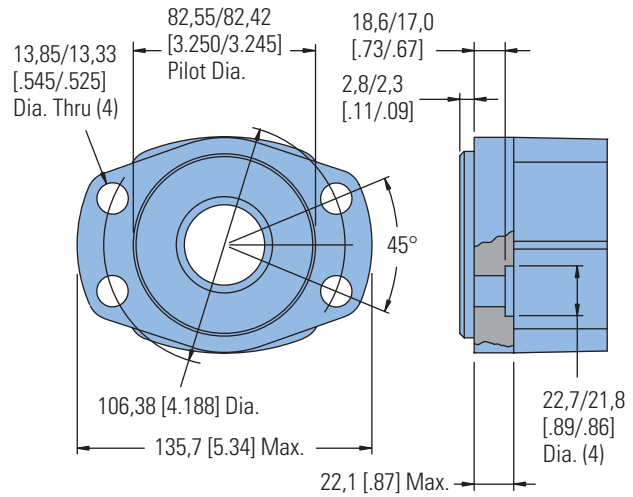

## Mounting Code : AB

### Four Bolt (Wheel Motor)

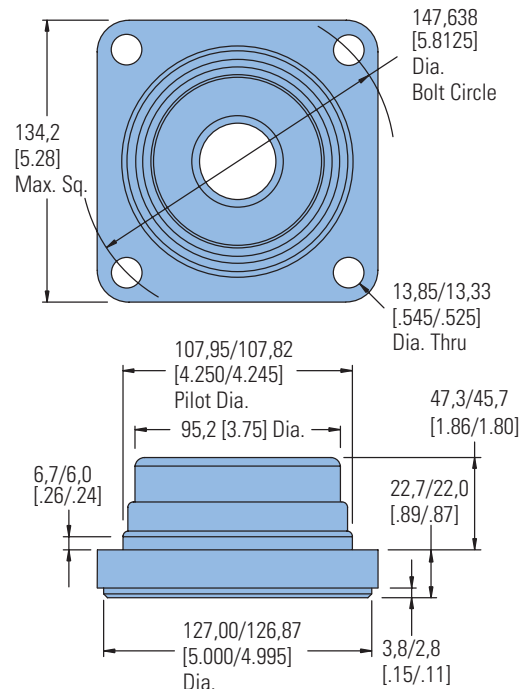

# 2000 Series

## Dimensions

### Shafts

#### Shaft Code: 01 1 Inch Straight

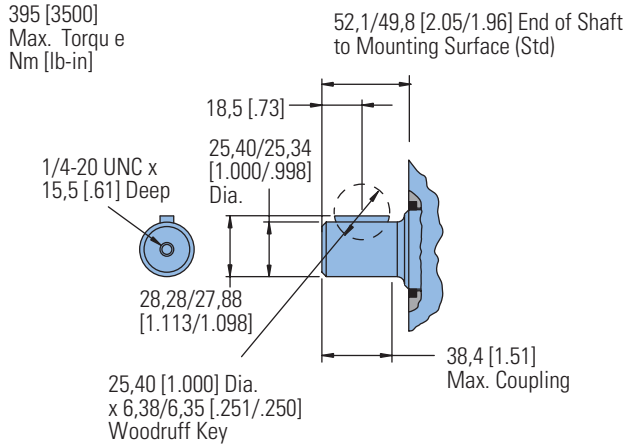

#### Shaft Code: 03 1 1/4 Inch Tapered

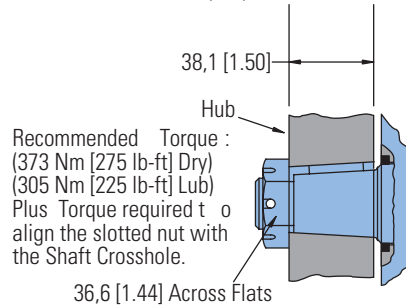
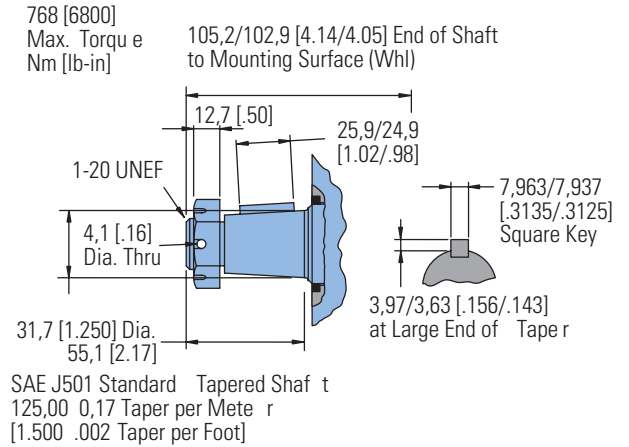

#### Shaft Code: 02 1 1/4 Inch Straight

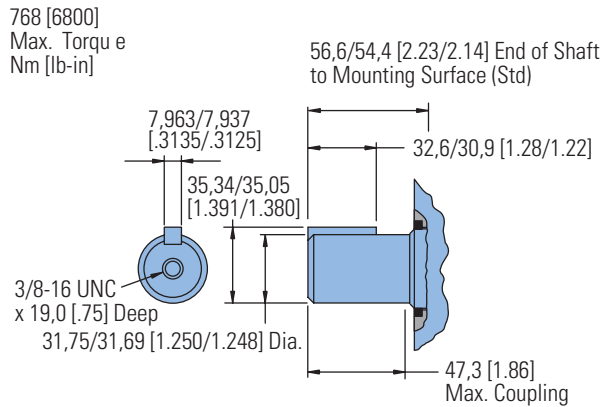

#### Shaft Code: 19 25 mm Straight

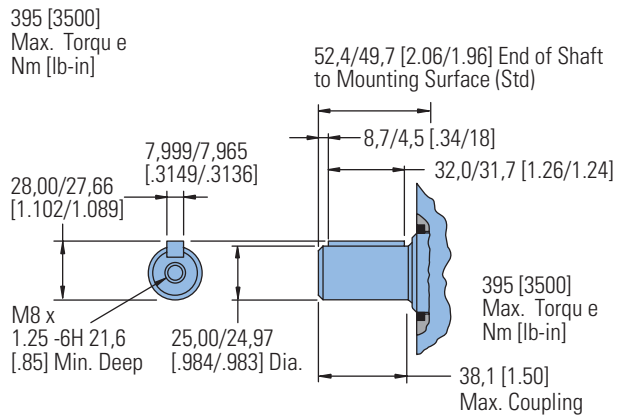

# 2000 Series

## Dimensions

### Shafts

#### Shaft Code: 16 32 mm Straight

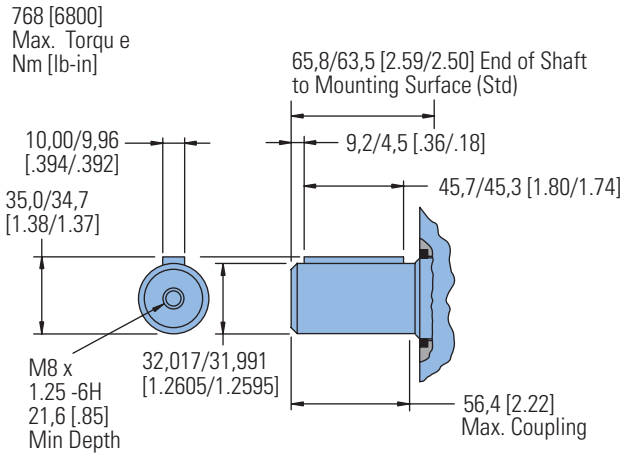

#### Shaft Code: 05 SAE 6B Splined

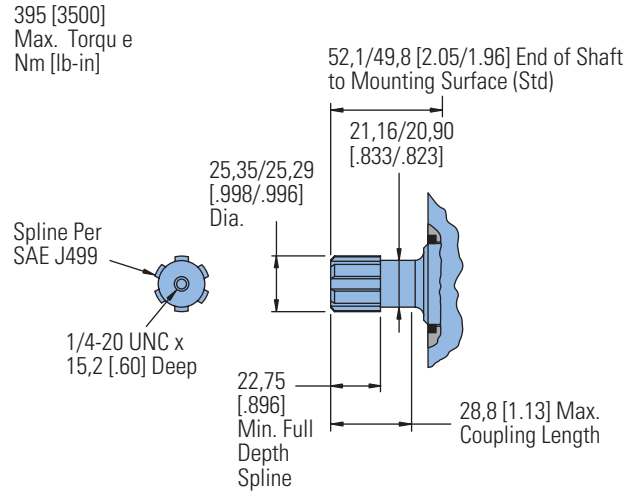

#### Shaft Code: 04 1 1/4 -14 Tooth Splined

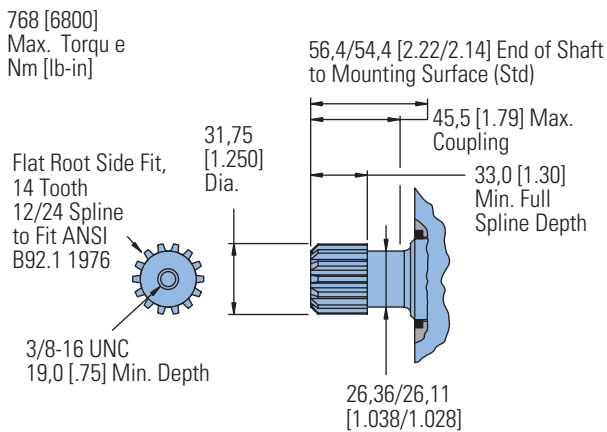

#### Shaft Code: 07 13 Tooth Splined

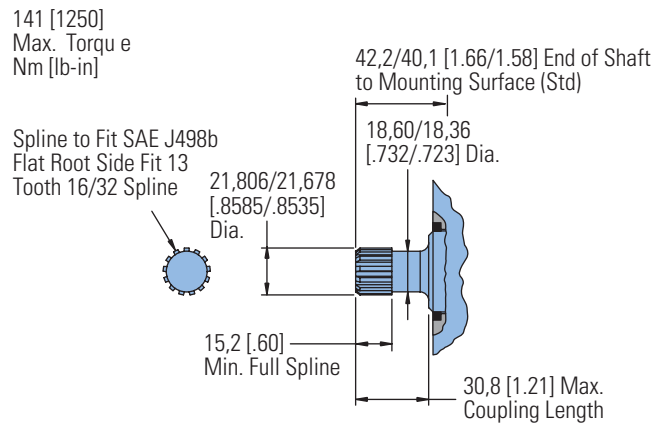

# 2000 Series

## Shaft Side Load Capacity

These curves indicate the radial load capacity on the motor shaft at various locations with an allowable external thrust load of 454 kg [1000 lb].

**Note:**

Case pressure will increase the allowable inward thrust load and decrease the allowable outward thrust load. Case pressure will push outward on the shaft at 61 kg/7 Bar [135 lb/100 PSI].

**Each curve is based on B 10 bearing life (2000**

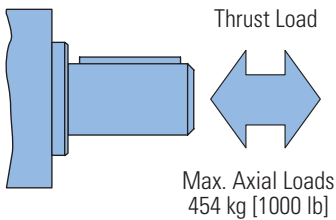

**hours of 12,000,000 shaft revolutions at 100 RPM) at rated output torque.**

To determine radial load at speeds other than 100 RPM, multiply the load values given on the bearing curve by the factors in the chart below.

RPM	Multiplication Factor
50	1.23
100	1.00
200	0.81
300	0.72
400	0.66
500	0.62
600	0.58
700	0.56
800	0.54

For 3,000,000 shaft revolutions or 500 hours—Increase these shaft loads 52%.

Standard Motor  
Straight and Splined Shafts

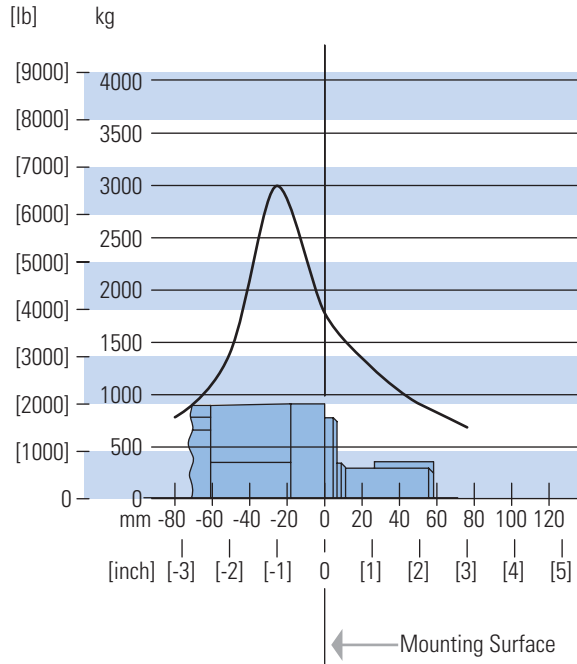

Wheel Motor  
Tapered Shaft

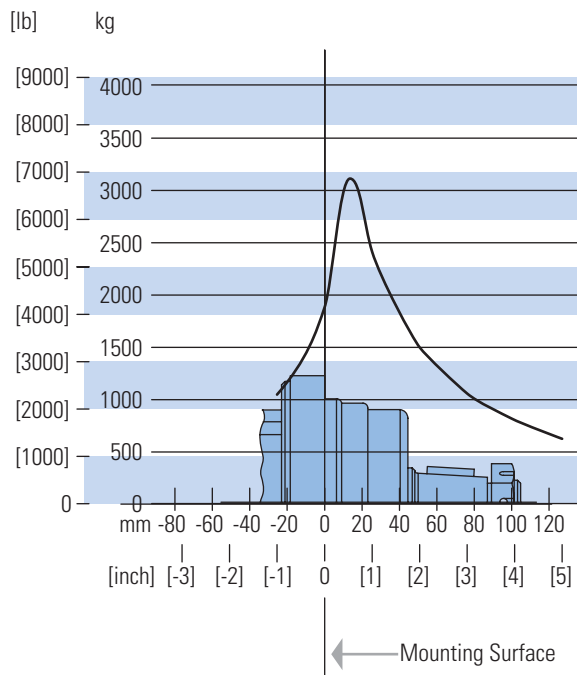



# 2000 Series

## Case Pressure and Case Porting

Char-Lynn 2000 Series motors are durable and have long life as long as the recommended case pressure is not exceeded. Allowable case pressure is highest at low shaft speeds. Consequently, motor life will be shortened if case pressure exceeds these ratings (acceptability may vary with application). Determine if an external case drain is required from the case pressure seal limitation chart.

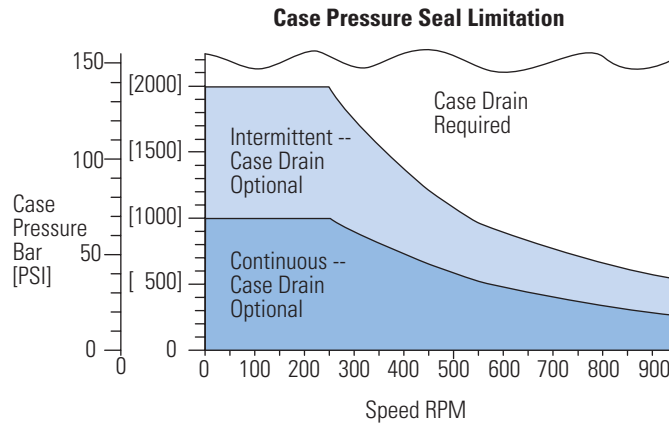

### Case Porting Advantage

**Contamination Control** — flushing the motor case.

**Cooler Motor** — exiting oil draws motor heat away.

**Extend Motor Seal Life** — maintain low case pressure with a preset restriction in the case drain line.

# 2000 Series

## Dimensions

### Ports

**Port Code: AA**

**Port Code: AG**

**7/8-14 UNF-2B SAE O-ring Ports (2)  
or G 1/2 (BSP) Ports (2)**

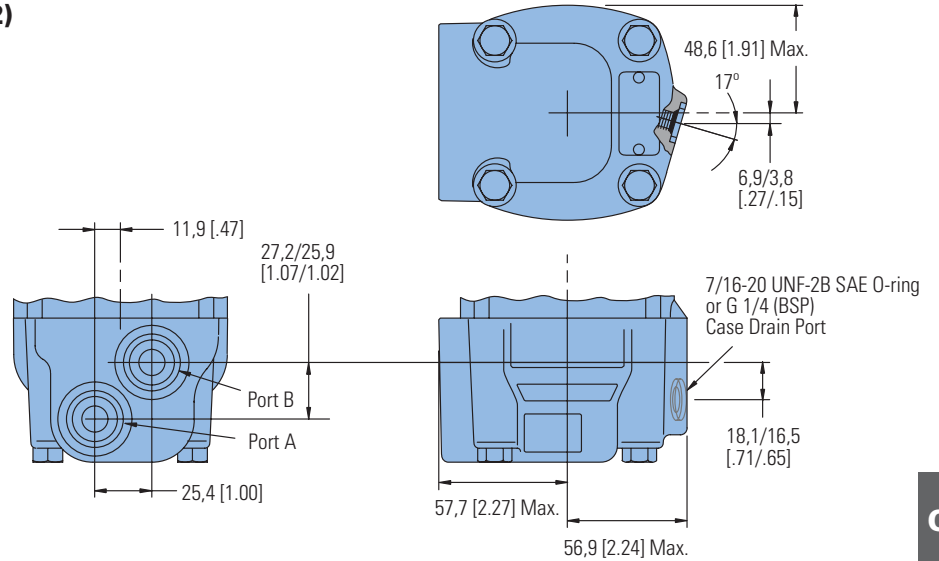

**Case Flow Code: 23**

**7/8-14 UNF-2B SAE O-ring Ports (2)  
with Top Ported Case Drain**

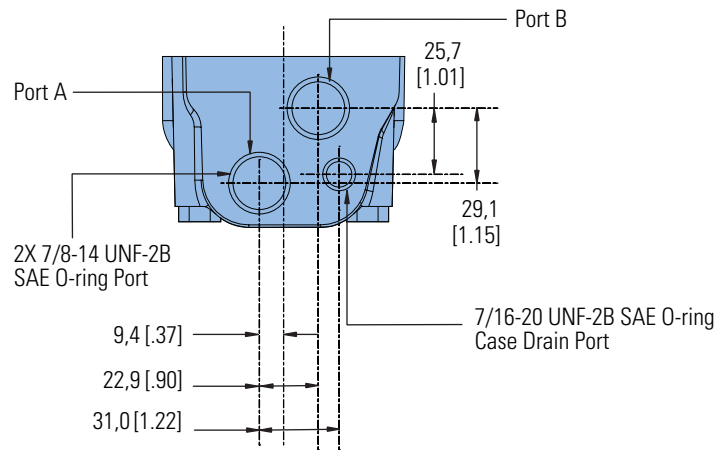

**Port Code: AB**

**Port Code: AE**

**Manifold Mount**

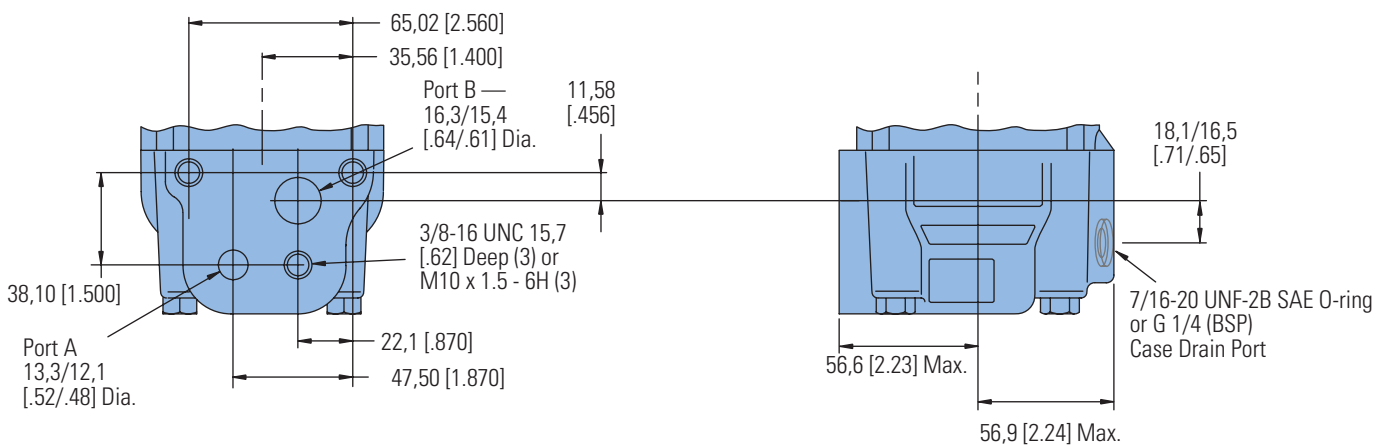

# 2000 Series

## Dimensions

### Ports

#### Port Code: AF

#### 1-1/16-12 UN-2B SAE O-ring Ports (2)

#### Positioned 180° Apart

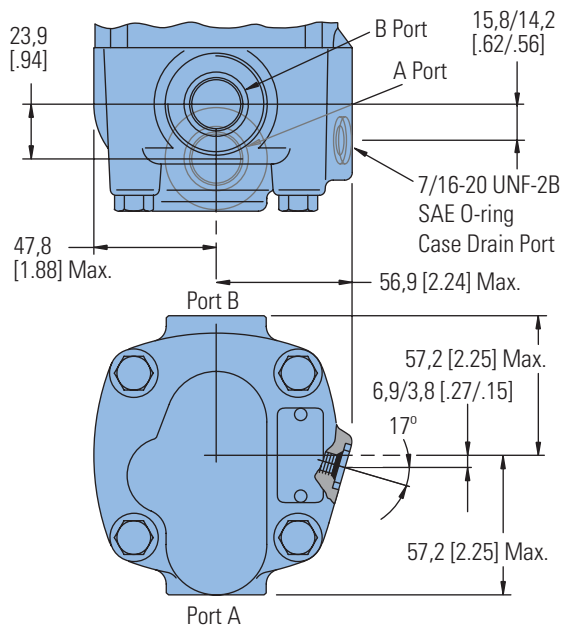

#### Port Code: AD

#### 7/8-14 UNF-2B SAE O-ring End Ports (2)

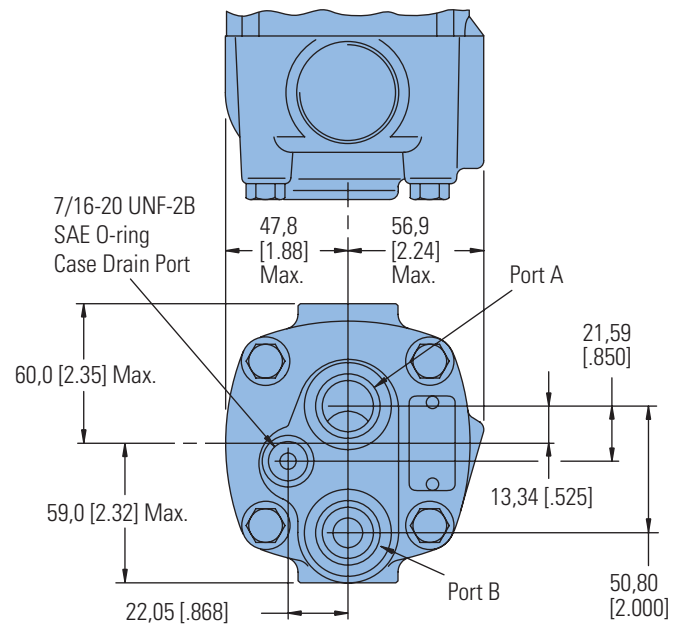

# 2000 Series

## Dimensions

### Ports with Shuttle

#### Port Code: AA

#### Port Code: AG

#### 7/8 -14 UNF-2B SAE O-ring Ports (2) or G 1/2 (BSP) Ports (2)

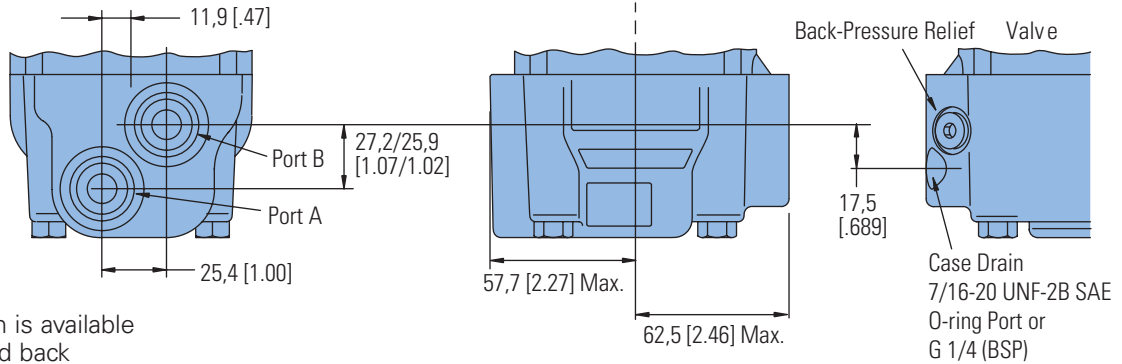

This port option is available with shuttle and back pressure relief valve for closed loop applications.

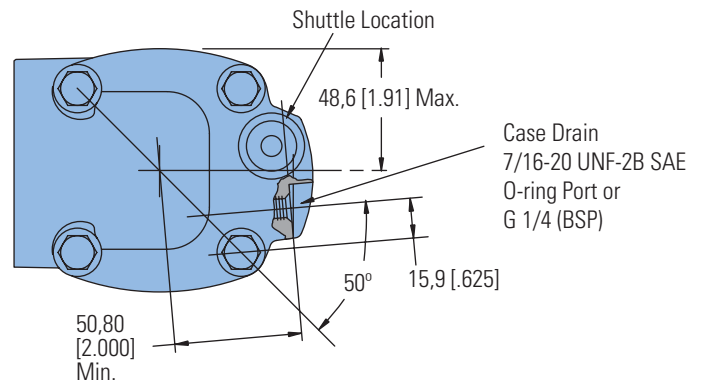

C-1

#### Port Code: AD

#### 7/8 -14 UNF-2B SAE O-ring End Ports (2)

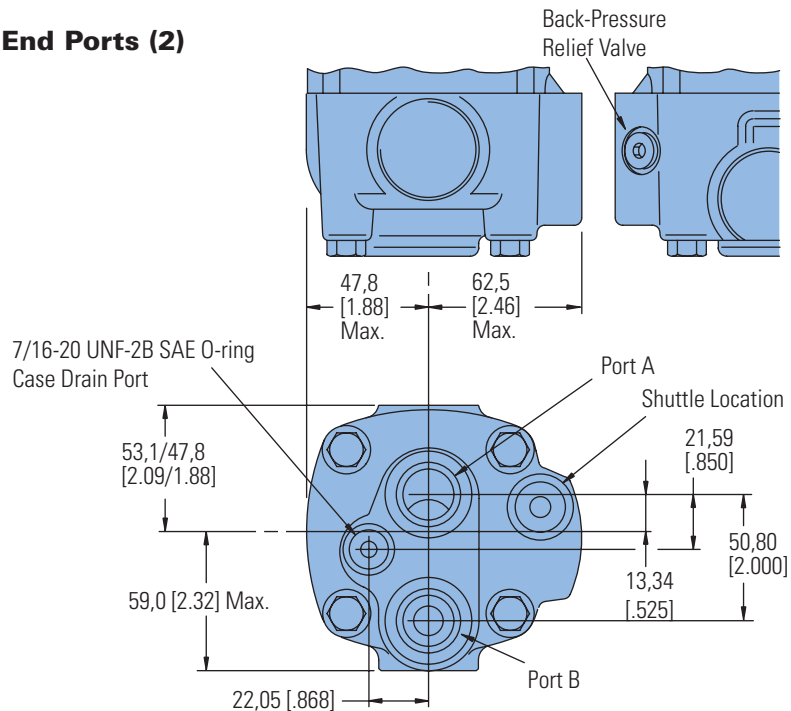

This port option is available with shuttle and back pressure relief valve for closed loop applications.

# 2000 Series

## Product Numbers

### Note:

For 2000 Series Motors with a configuration **Not Shown** in the charts below: Use model code number system on the next page to specify product in detail.

Use digit prefix — 104-, 105-, or 106- plus four digit number from charts for complete product number— Example 106-1043.

**Orders will not be accepted without three digit prefix.**

MOUNTING SHAFT	PORT SIZE	DISPL. cm <sup>3</sup> / r [in <sup>3</sup> / r]/ PRODUCT NUMBER											
		41* [2.5]	80 [4.9]	90 [5.5]	100 [6.2]	130 [8.0]	160 [9.6]	195 [11.9]	245 [14.9]	305 [18.7]	395 [24.0]	490 [29.8]	
2 Bolt SAE A Flange	1 Inch Straight	7/8 -14 O-ring Staggered	104-4708	-1001	—	-1002	-1003	-1004	-1005	-1006	-1007	-1143	—
		1 1/16 -12 O-ring 180° Apart	104—	-1037	—	-1038	-1039	-1040	-1041	-1042	-1043	-1044	—
	1 1/4 Inch Straight	7/8 -14 O-ring Staggered	104-4774	-1022	—	-1023	-1024	-1025	-1026	-1027	-1028	-1228	-1420
		1 1/16 -12 O-ring 180° Apart	104—	-1061	—	-1062	-1063	-1064	-1065	-1066	-1067	-1068	-1421
	1 1/4 Inch - 14 T Splined	7/8 -14 O-ring Staggered	104-4764	-1029	—	-1030	-1031	-1032	-1033	-1034	-1035	-1229	-1422
		1 1/16 -12 O-ring 180° Apart	104—	-1087	—	-1088	-1089	-1090	-1091	-1092	-1093	-1094	-1423
2 Bolt SAE B Flange	1 1/4 Inch Straight	7/8-14 O-ring Staggered	104—	-1200	—	-1201	-1202	-1203	-1204	-1205	-1206	-1207	—
	1 1/4 Inch Involute SAE C Splined	7/8 -14 O-ring Staggered	104—	-1208	—	-1209	-1210	-1211	-1212	-1213	-1214	-1215	—
	1 Inch SAE 6B Splined	7/8 -14 O-ring Staggered	104—	-1193	—	-1194	-1195	-1196	-1197	-1198	-1199	—	—
	7/8 Inch SAE B Splined	7/8 -14 O-ring Staggered	104—	-1216	—	-1217	-1218	-1219	-1220	—	—	—	—
Standard with 4 Bolt Flange	32 mm Straight	G 1/2 (BSP))	104-4672	-1384	—	-1385	-1386	-1387	-1388	-1389	-1390	-1391	—
	1 1/4 Inch 14 T Splined	G 1/2 (BSP)	104—	-1376	—	-1377	-1378	-1379	-1380	-1381	-1382	-1383	—
Wheel Motor	1 1/4 Inch Straight	7/8 -14 O-ring Staggered	105—	—	—	—	—	—	—	—	—	—	-1148
		1 1/16 -12 O-ring 180° Apart	105—	—	—	—	—	—	—	—	—	—	—
	32 mm Straight	G 1/2 (BSP)	105—	-1134	—	-1135	-1136	-1137	-1138	-1139	-1140	-1141	—
	1 1/4 Inch Tapered	7/8 -14 O-ring Staggered	105—	-1001	—	-1002	-1003	-1004	-1005	-1006	-1007	-1060	-1152
		1 1/16 -12 O-ring 180° Apart	105—	-1071	—	-1072	-1073	-1074	-1075	-1076	-1077	-1078	—
	1 1/4 Inch 14 T Splined	7/8 -14 O-ring Staggered	105—	-1029	—	-1030	-1031	-1032	-1033	-1034	-1035	-1096	—
1 1/16 -12 O-ring 180° Apart		105—	-1079	—	-1080	-1081	-1082	-1083	-1084	-1085	-1086	—	
Bearingless	7/8 -14 O-ring Staggered	106—	-1008	—	-1009	-1010	-1011	-1012	-1013	-1014	-1015	-1047	
	G 1/2 (BSP)	106—	-1038	—	-1039	-1040	-1041	-1042	-1043	-1044	-1045	—	

\*New Release

106-1044

MOUNTING SHAFT	PORT SIZE	DISPL. cm <sup>3</sup> / r [in <sup>3</sup> / r]/ PRODUCT NUMBER											
		41* [2.5]	80 [4.9]	90 [5.5]	100 [6.2]	130 [8.0]	160 [9.6]	195 [11.9]	245 [14.9]	305 [18.7]	395 [24.0]	490 [29.8]	
2 Bolt SAE A Flange	1 Inch Straight	7/8 -14 O-ring Staggered	104—	-1528	—	-1529	-1530	-1531	-1532	-1533	-1534	-1519	-1535
	1 1/4 Inch Straight	7/8 -14 O-ring	104—	-1516	—	-1536	-1537	-1538	-1539	-1452	-1479	-1509	-1489

\*New Release

# 2000 Series

## Model Code

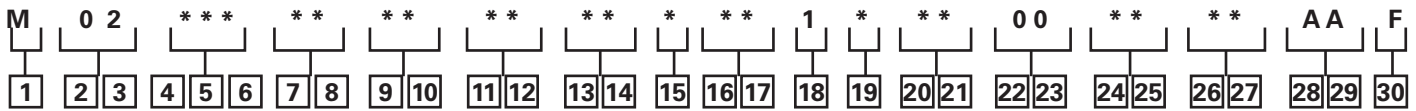

**1** Product  
M – 2000 Series Motor

**2**, **3** Product Series  
02 – 2000 Series Motor

**4**, **5**, **6** Displacement  
021 - 34 cm<sup>3</sup>/r [ 2.07 in<sup>3</sup>/r]  
025 - 40.8 cm<sup>3</sup>/r [ 2.49 in<sup>3</sup>/r]  
040 - 66.5 cm<sup>3</sup>/r [ 4.06 in<sup>3</sup>/r]  
**049 – 80.6 cm<sup>3</sup>/r [ 4.92 in<sup>3</sup>/r]**  
055 – 90.6 cm<sup>3</sup>/r [ 5.53 in<sup>3</sup>/r]  
**062 – 101.6 cm<sup>3</sup>/r [ 6.20 in<sup>3</sup>/r]**  
**080 – 130.6 cm<sup>3</sup>/r [ 7.97 in<sup>3</sup>/r]**  
**096 – 158.1 cm<sup>3</sup>/r [ 9.65 in<sup>3</sup>/r]**  
**119 – 194.8 cm<sup>3</sup>/r [ 11.89 in<sup>3</sup>/r]**  
**149 – 244.3 cm<sup>3</sup>/r [ 14.91 in<sup>3</sup>/r]**  
**187 – 306.6 cm<sup>3</sup>/r [ 18.71 in<sup>3</sup>/r]**  
**240 – 393.8 cm<sup>3</sup>/r [ 24.03 in<sup>3</sup>/r]**  
298 – 489.0 cm<sup>3</sup>/r [ 29.84 in<sup>3</sup>/r]

**7**, **8** Mounting Type  
**AB – Wheel, 4 Bolt: 108.0 [4.25] Pilot Dia. 13.59 [.535] Dia. Holes on 147.6 [5.81] Dia. Bolt Circle. 127.0 [5.00] Dia. Rear Mount Pilot**  
**AC – Standard, 2 Bolt: 82.6 [3.25] Pilot Dia. 13.59 [.535] Dia. Holes on 106.4 [4.19] Dia. Bolt Circle. SAE A**  
AD – Bearingless (w/ Leakage Slots), 4 Bolt: 101.6 [4.00] Pilot Dia. 13.59 [.535] Dia. Holes on 127.0 [5.00] Dia. Bolt Circle  
AF – Standard, 2 Bolt: 101.6 [4.00] Pilot Dia. 14.35 [.565] Dia. Holes on 146.0 [5.75] Dia. Bolt Circle. SAE B  
**AH – Standard, 4 Bolt: 82.6 [3.25] Pilot Dia. 13.59 [5.35] Dia. Holes on 106.4 [4.19] Dia. Bolt Circle**  
**AJ – Standard (Magneto), 4 Bolt: 82.6 [3.25] Pilot Dia. 13.59 [5.35] Dia. Holes on 106.4 [4.19] Dia. Bolt Circle. 2.79 [1.10] Pilot Length**  
AL - Wheel (European), 4 Bolt: 125 [4.92] Pilot Dia. 13.79 [.543] Dia. Holes on 159.99 [6.299] Dia. Bolt Circle  
AP – Wheel, 4 Bolt: 108.0 [4.25] Pilot Dia. 13.59 [.535] Dia. Holes on 147.6 [5.81] Dia. Bolt Circle. 127.0 [5.00] Dia. Rear Mount Pilot. Spigot Reduced to 88.9 [3.50] Dia. by 25.4 [1.00] Depth.

The following 30-digit coding system has been developed to identify all of the configuration options for the 2000 Series motor. Use this model code to specify a motor with the desired features. All 30 digits of the code must be present when ordering. You may want to photocopy the matrix below to ensure that each number is entered in the correct box.

**9**, **10** Output Shaft  
00 – None (Bearingless)  
**01 – 25.40 [1.000] Dia. Straight Shaft with 1/4-20UNC-2B Thread in End, 6.35 [.250] Wide x 25.40 [1.000] Dia. Woodruff Key**  
**02 – 31.75 [1.250] Dia. Straight Shaft with .375-16UNC-2B Thread in End, 7.938 [.3125] Sq x 31.75 [1.250] Straight Key**  
**03 – 31.75 [1.250] Dia. .125:1 Tapered Shaft per SAE J501 with/1.000-20 UNEF-2A Threaded Shaft End and Slotted Hex Nut, 7.938 [.3125] Sq x 25.40 [1.0] Straight Key**  
**04 – 31.75 [1.250] Dia. Flat Root Side Fit, 14 Tooth, 12/24 DP 30° Involute Spline w/ .375-16UNC-2B Thread in End, 33.0 [1.30] Min. Full Spline Length**  
05 – 25.40 [1.000] Dia. 6B Spline per SAE J499 with .250-20UNC-2B Thread in End, 22.76 [.896] Min. Full Spline Length  
07 – 22.22 [.875] Dia. Flat Root Side Fit, 13 Tooth, 16/32 DP 30° SAE B Involute Spline, 15.2 [.60] Min. Full Spline Length  
**16 – 32.00 [1.260] Dia. Straight Shaft with M8 x 1.25-6H Thread in End, 9.982 [.3930] W x 7.995 [.3132] H x 45.00 [1.772] L Key**  
17 – 31.75 [1.250] Dia. Straight Shaft With 3/8 -16 UNC-2B Thread in End, 7.938 [.3125] Sq x 31.75 [1.250] Straight Key, Corrosion Resistant (Seal area to shaft end)  
19 – 25.00 [.984] Dia. Straight Shaft with M8 x 1.25-6h Thread in End, 7.982 [.3142]W x 6.954 [.2738]H x 31.82 [1.254]L Key  
41 – 35.00 [1.378] Dia. 10:1 Tapered Shaft Per ISO R775 with M20 x 1.5-6g Threaded Shaft End and Slotted Hex Nut, 6.00 [.236] Sq. X 20.00 [.787] Key  
42 – 35.00 [1.378] Dia. Straight Shaft with M8 x 1.25-6h Thread in End, 9.982 [.3930]W x 7.995 [.3132]H x 45.00 [1.772]L Key

**11**, **12** Ports  
**AA – .875-14 UNF-2B SAE O-ring Ports - Staggered Ports**  
AB – 12.70 [.500] and 15.88 [.625] Dia. Manifold Ports with 3 x .375-16 UNC-2B Port Block Mounting Holes  
AC – .875-14 UNF-2B SAE O-ring Ports - Ports Oriented 180° to each other  
AE – 12.70 [.500] And 15.88 [.625] Dia. Manifold Ports with 3 x M10 x 1.5-6H Port Block Mounting Holes  
**AF – 1.0625-12 UN-2B SAE O-ring Ports - Ports Oriented 180° to each other**  
**AG – G-1/2 BSP Straight THD Ports - Staggered Ports**  
AN – G-1/2 BSP Straight THD Ports - End Ported  
AS – G-1/2 Bsp Straight THD Ports - Staggered Port with 2 x M10 x 1.5-6H Port Block Mounting Holes - European

**13**, **14** Case Flow Options  
Shuttles available with port code AA only  
**01 – .4375-20 UNF-2B SAE O-Ring Port**  
**02 – G 1/4 BSP Straight THD Port**  
09 – Reverse Flow Shuttle Valve w/ G-1/4 BSP Straight THD Port, .062 Dia. Shuttle Flow Orifice  
13 – Reverse Flow Shuttle Valve w/ .4375-20 UNF-2B SAE O-Ring Port, .062 Dia. Shuttle Flow Orifice

**15** Low Pressure Relief  
**0 – None**  
A – Set at 4.5 bar [65 lbf/in<sup>2</sup>]  
B – Set at 15.2 bar [220 lbf/in<sup>2</sup>]  
C – Set at 20.7 bar [300 lbf/in<sup>2</sup>]  
E – Set at 11.03 bar [160 lbf/in<sup>2</sup>]

**16**, **17** Pressure/Flow Option  
**00 – None**  
Integral Cross-Over Relief Valve:  
30 – Set at 103.4 bar [1500 lbf/in<sup>2</sup>]  
31 – Set at 120.6 bar [1750 lbf/in<sup>2</sup>]  
32 – Set at 137.9 bar [2000 lbf/in<sup>2</sup>]  
33 – Set at 155.1 bar [2250 lbf/in<sup>2</sup>]  
34 – Set at 172.4 bar [2500 lbf/in<sup>2</sup>]  
35 – Set at 189.6 bar [2750 lbf/in<sup>2</sup>]  
36 – Set at 206.8 bar [3000 lbf/in<sup>2</sup>]  
51 – Set at 234.4 bar [3400 lbf/in<sup>2</sup>]

**18** Geroler Option  
**1 – Standard**  
2 – Free Running  
6 – Reduced side clearance, no warranty for galling

**19** Seal Options  
**0 – Standard**  
1 - Viton  
2 - Viton Shaft Seal  
3 - High Pressure Shaft Seal  
4 - Seal Guard  
5 - Extreme Duty Seal Guard  
6 - High Pressure Shaft Seal, Seal Guard

**20**, **21** Accessories  
**00 – None**  
AA - Long Body Digital Speed Pickup (30 Pulse) 127 [5.0] Lead Wire With Packard Weather Pac Shroud Connector (A=Power, B=Signal, C=Common)  
AD – M 12 Threaded Connector, Digital Speed Pickup (30 Pulse)  
AG - M 12 Threaded Connector, Digital Speed And Direction Pickup (One 60 Pulse Per Rev Speed Signal And One Directional Signal (Pin 1=Power, Pin 2=Direction, Pin 3=Common, Pin 4=Speed))

**22**, **23** Special Features (Hardware)  
**00 – None**

**24**, **25** Special Features (Assembly)  
**00 – None**  
AA – Flange rotated 90 degrees  
AB – Reverse Rotation  
AE - Flange Rotated 45 Degrees

**26**, **27** Paint/Packaging  
**AA – No Paint, Indiv. Box**  
**AB – Low Gloss Black Primer, Indiv. Box**  
AT – Environmental coated black, individual box  
BJ – Nickel plated motor (excluding shaft), individual box

**28**, **29** Customer ID  
**AA – None**

**30** Design Code  
**F – Sixth**  
Feature in bold are preferred and allow for shorter lead time



# 2000 Series Two-Speed

## Description

The Eaton 2000 Series motors are available with an integral two speed feature that changes the displacement in a ratio of 1 to 2 and shifts the motor from a low speed high torque (LSHT) mode to a high speed low torque (HSLT) mode. The open center selector valve shifts the speed mode from low to high speed when pilot pressure of 6.9  $\Delta$  Bar [100  $\Delta$  PSI] minimum is applied to the pilot port (6.9 Bar [100 PSI] higher than case pressure). In the high speed mode torque values are approximately one half with twice the speed of the conventional 2000 Series single speed motors.

An external two position three way valve is required for shifting the pilot pressure port between signal pressure (HSLT) and low pressure (LSHT)

Two speed motors are available with a return line closed center shuttle for closed circuit applications. Low speed high torque mode is the normal position of the speed selector valve. When a differential pressure is supplied to the pilot port and 6,9 Bar [100 PSI] is reached, the selector valve overcomes the return spring force and the spool shifts to the high speed mode. The oil in the opposite side of the spool is drained internally. Pressure between the pilot supply and case drain or return line (depending on open or closed circuit system) must be maintained to keep the motor in the high speed mode.

When pilot pressure is removed from the pilot port the pressure in the pilot end of the spool valve is relieved and drained back through this three way valve,

the spring force returns the spool valve to LSHT position. Pilot pressure may come from any source that will provide uninterrupted pressure during the high speed mode operation. Pilot pressure 6,9  $\Delta$  Bar [100  $\Delta$  PSI] minimum, up to the full operating pressure of the motor.

In normal LSHT operation the Char-Lynn two speed motor will function with equal shaft output in either direction (CW or CCW), the same as the single speed Char-Lynn disc valve motors.

However, to prevent cavitation in the HSLT mode, the preferred direction of shaft rotation is counter clockwise (port B pressurized). This unique disc valve is not symmetrical in porting the fluid for the HSLT mode. Consequently, when the pressure is reversed for HSLT CW rotation, cavitation

can occur. Installing a restriction (200 psi or more depending on flow) in the hydraulic line that connects port B will prevent cavitation.

If you are operating in a critical area and a restriction in the hydraulic line causes concern, these two speed motors can be ordered timed with CW preferred HSLT shaft rotation. Hence, with this option port B will have to be pressurized for CW preferred HSLT shaft rotation. The restriction recommended for the line connecting port B remains unchanged.

Finally in closed circuit applications a hydraulic line restriction is not required. Instead, the charge pump can be used to supply and maintain a minimum pressure of 14 Bar [200 PSI].

## Performance Data

**In the high speed mode torque values are approximately one half with twice the speed** of the conventional 2000 Series single speed motors.

**In the low speed mode torque and speed values are the same as the conventional 2000 Series motors.**

### Note:

Low displacement (4.9 to 8.0 CID) motors have limited starting torque when started in high speed mode.

**Be certain in closed loop applications that the charge pump when used for back pressure on the B port, has sufficient displacement to maintain charge pressure especially in dynamic braking or overrunning load conditions.**

### Important!

**Due to potential problems in maintaining charge pump pressure at port B for uninterrupted back pressure during dynamic braking, Eaton does not recommend the two speed motor where overrunning conditions may exist.**

# 2000 Series Two-Speed

## Typical Hydraulic Circuit

### Note:

This is the low speed biased motor circuit. For the high speed biased motor motor circuit please contact your Eaton Hydraulics representative.

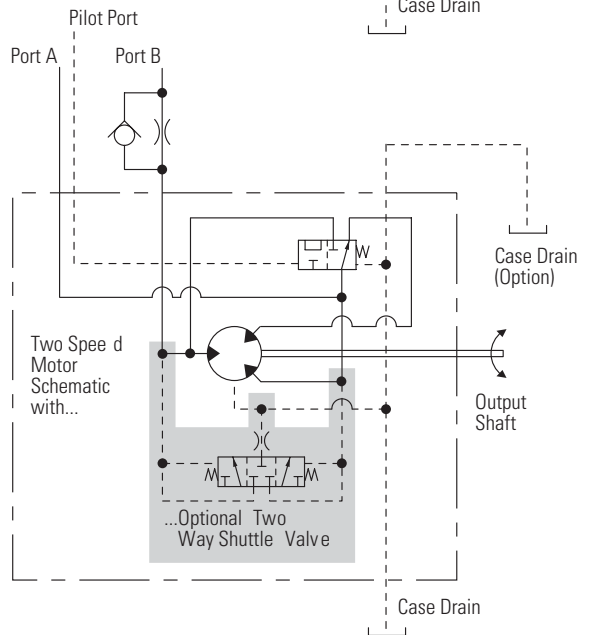
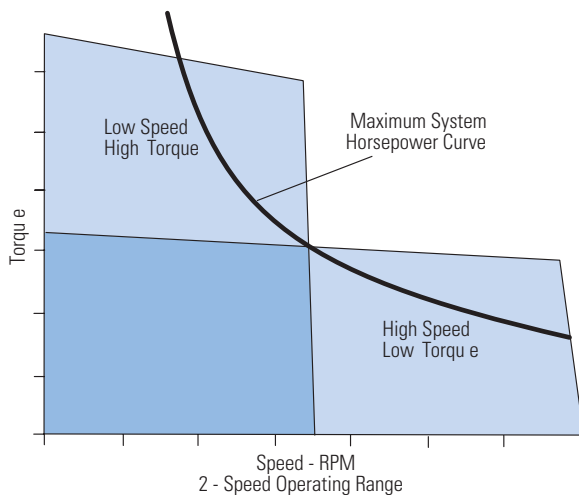
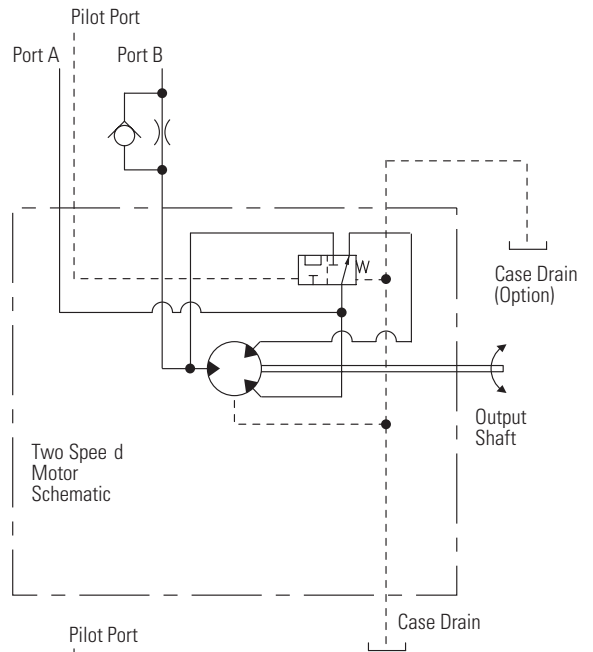
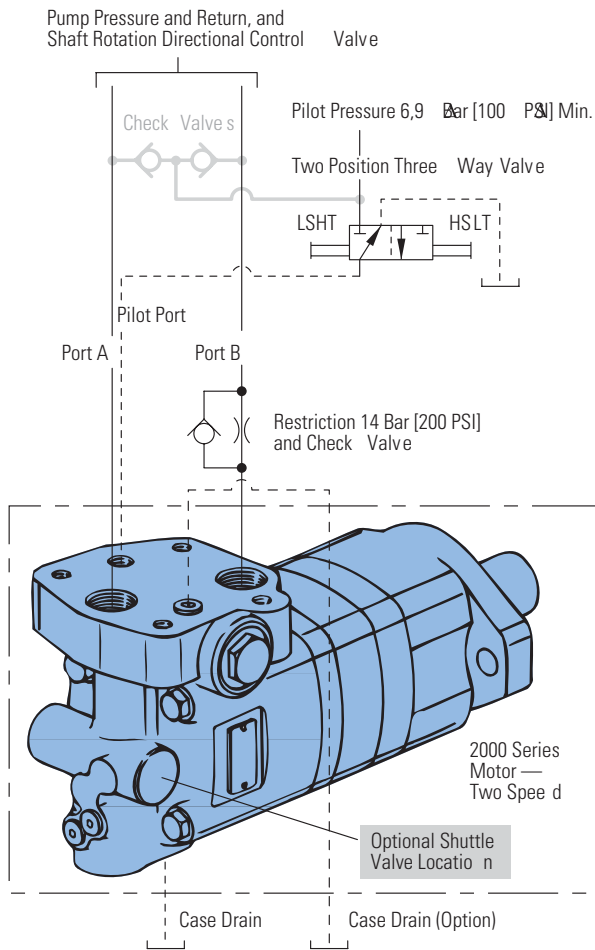

C-1



# 2000 Series Two-Speed

## Specifications

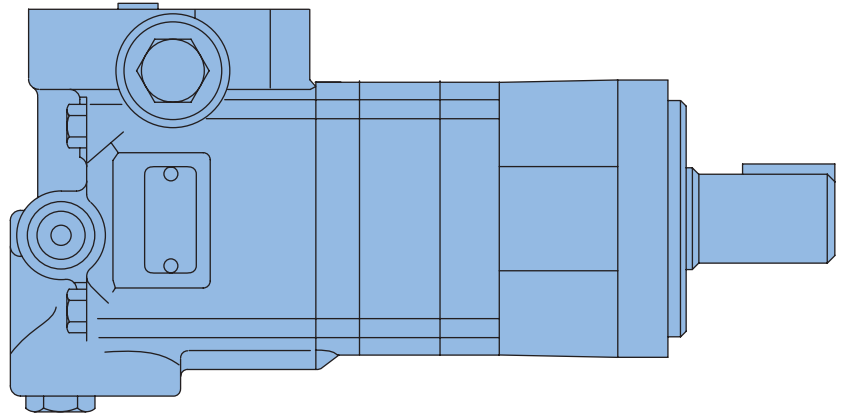

### SPECIFICATION DATA – 2000 SERIES TWO-SPEED MOTORS

Displ. cm <sup>3</sup> /r [in <sup>3</sup> /r]	High Speed Mode	40 [2.45]	50 [3.1]	65 [4.0]	80 [4.8]	95 [5.95]	120 [7.45]	155 [9.35]	195 [12.0]	245 [14.9]
	Low Speed Mode	80 [4.9]	100 [6.2]	130 [8.0]	160 [9.6]	195 [11.9]	245 [14.9]	305 [18.7]	395 [24.0]	490 [29.8]
Max. Speed (RPM) @ Continuous Flow	High Speed Mode	1000	1000	990	860	700	560	450	350	230
	Low Speed Mode	500	500	495	430	350	280	225	175	115
Flow l/min [GPM]	High Speed Mode	45 [12]	55 [15]	70 [19]	75 [20]	75 [20]	75 [20]	75 [20]	75 [20]	75 [20]
	Low Speed Mode	45 [12]	55 [15]	70 [19]	75 [20]	75 [20]	75 [20]	75 [20]	75 [20]	75 [20]
Torque* Nm [lb-in]	High Speed Mode									
	Continuous	100 [880]	125 [1115]	165 [1450]	195 [1725]	240 [2150]	300 [2675]	380 [3350]	365 [3225]	448 [3970]
	Intermittent	145 [1300]	185 [1660]	240 [2150]	240 [2150]	300 [2650]	375 [3330]	440 [3900]	445 [3940]	486 [4300]
Torque* Nm [lb-in]	Low Speed Mode									
	Continuous	235 [2065]	295 [2630]	385 [3420]	455 [4040]	540 [4780]	660 [5850]	765 [6750]	775 [6840]	845 [7470]
	Intermittent	345 [3035]	445 [3950]	560 [4970]	570 [5040]	665 [5890]	820 [7250]	885 [7820]	925 [8170]	930 [8225]
Pressure Δ bar [Δ PSI]	Continuous	205 [3000]	205 [3000]	205 [3000]	205 [3000]	205 [3000]	205 [3000]	205 [3000]	155 [2250]	120 [1750]
	Intermittent	310 [4500]	310 [4500]	310 [4500]	260 [3750]	260 [3750]	260 [3750]	240 [3500]	190 [2750]	140 [2000]
Weight kg [lb]	Standard or Wheel Mount	13,8 [30.5]	14,1 [31.0]	14,3 [31.5]	14,5 [32.0]	15,0 [33.0]	15,4 [34.0]	15,9 [35.0]	16,3 [36.0]	16,8 [37.0]
	Bearingless	11,8 [26.0]	12,0 [26.5]	12,2 [27.0]	12,5 [27.5]	12,9 [28.5]	13,4 [29.5]	13,8 [30.5]	14,3 [31.5]	14,7 [32.5]

Maximum Case Pressure: See case pressure seal limitation graph.

\*See shaft torque ratings for limitations.

#### Note:

To assure best motor life, run motor for approximately one hour at 30% of rated pressure before application to full load. Be sure motor is filled with fluid prior to any load applications.

#### High Speed Mode

(Reduced Motor Displacement)

#### Low Speed Mode

(Full Motor Displacement)

#### Maximum Inlet Pressure:

310 bar [4500 PSI]

Do not exceed Δ pressure rating (see chart above).

#### Maximum Return Pressure:

310 bar [4500 PSI] with case drain line installed.

Do not exceed Δ pressure rating (see chart above).

#### Δ bar [Δ PSI] :

The true pressure difference between inlet port and outlet port

#### Continuous Rating:

Motor may be run continuously at these ratings

#### Intermittent Operation:

10% of every minute

#### Peak Operation:

1% of every minute

#### Recommended Fluids:

Premium quality, anti-wear type hydraulic oil with a viscosity of not less than 70 SUS at operating temperature.

#### Recommended System Operating Temp.:

-34°C to 82°C [-30°F to 180°F]

#### Recommended Filtration:

per ISO Cleanliness Code, 4406: 20/18/13

# 2000 Series Two-Speed

## Dimensions

### Standard and Wheel

## Ports

- 7/8 -14 UNF-2B SAE O-ring Staggered Ports (2)
- 9/16 -18 UNF-2B SAE O-ring Case Drain Port (1)
- 7/16 -20 UNF-2B SAE O-ring Pilot Control Port (1) or
- G 1/2 (BSP) Staggered Ports (2)
- G 1/4 (BSP) Case Drain Port (1)
- G 1/4 (BSP) Pilot Control Port (1)

## Standard Rotation Viewed from Shaft End

- Port A Pressurized — CW
- Port B Pressurized — CCW

## Two-Speed Standard Motors

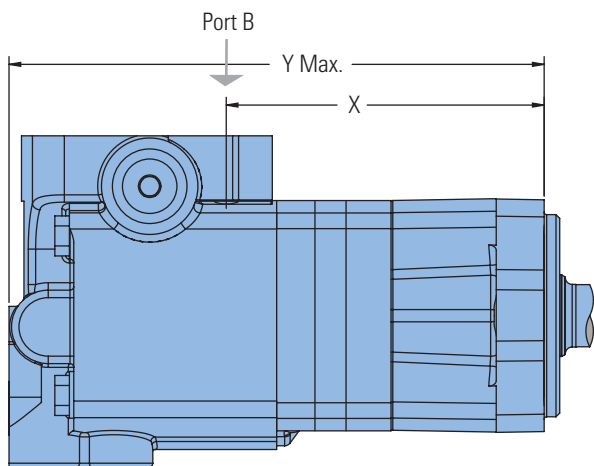

## STANDARD MOUNT MOTOR DIMENSIONS

Displacement cm <sup>3</sup> /r [in <sup>3</sup> /r]	X mm [inch]	Y mm [inch]
80 [4.9]	137,4 [5.41]	231,6 [9.12]
100 [6.2]	142,0 [5.59]	236,5 [9.31]
130 [8.0]	148,5 [5.85]	242,9 [9.56]
160 [9.6]	148,5 [5.85]	242,9 [9.56]
195 [11.9]	155,2 [6.11]	249,4 [9.82]
245 [14.9]	164,2 [6.47]	258,6 [10.18]
305 [18.7]	175,7 [6.92]	270,1 [10.63]
395 [24.0]	191,5 [7.54]	286,1 [11.26]
490 [29.8]	209,0 [8.23]	303,3 [11.94]

C-1

## Two-Speed Wheel Motors

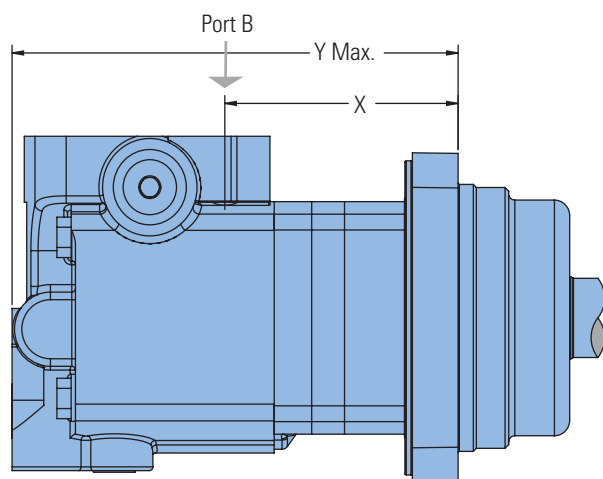

## WHEEL MOUNT MOTOR DIMENSIONS

Displacement cm <sup>3</sup> /r [in <sup>3</sup> /r]	X mm [inch]	Y mm [inch]
80 [4.9]	97,2 [3.83]	191,5 [7.54]
100 [6.2]	101,8 [4.01]	196,4 [7.73]
130 [8.0]	108,3 [4.27]	202,7 [7.98]
160 [9.6]	108,3 [4.27]	202,7 [7.98]
195 [11.9]	115,0 [4.53]	209,3 [8.24]
245 [14.9]	124,2 [4.89]	218,5 [8.60]
305 [18.7]	135,5 [5.34]	229,9 [9.05]
395 [24.0]	151,4 [5.96]	245,9 [9.68]
490 [29.8]	168,9 [6.65]	263,1 [10.36]

# 2000 Series Two-Speed

Dimensions

Bearingless

## Ports

- 7/8 -14 UNF-2B SAE O-ring Staggered Ports (2)
- 9/16 -18 UNF-2B SAE O-ring Case Drain Port (1)
- 7/16 -20 UNF-2B SAE O-ring Pilot Control Port (1) or
- G 1/2 (BSP) Staggered Ports (2)
- G 1/4 (BSP) Case Drain Port (1)
- G 1/4 (BSP) Pilot Control Port (1)

## Standard Rotation Viewed from Shaft End

- Port A Pressurized — CW
- Port B Pressurized — CCW

## Two-Speed Bearingless Motors

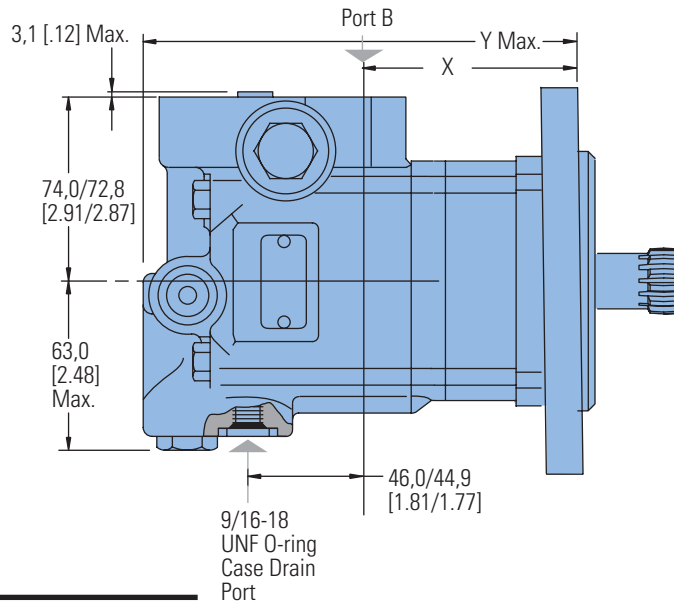
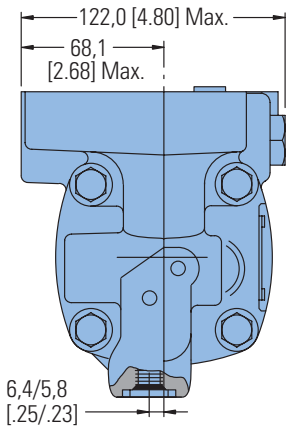
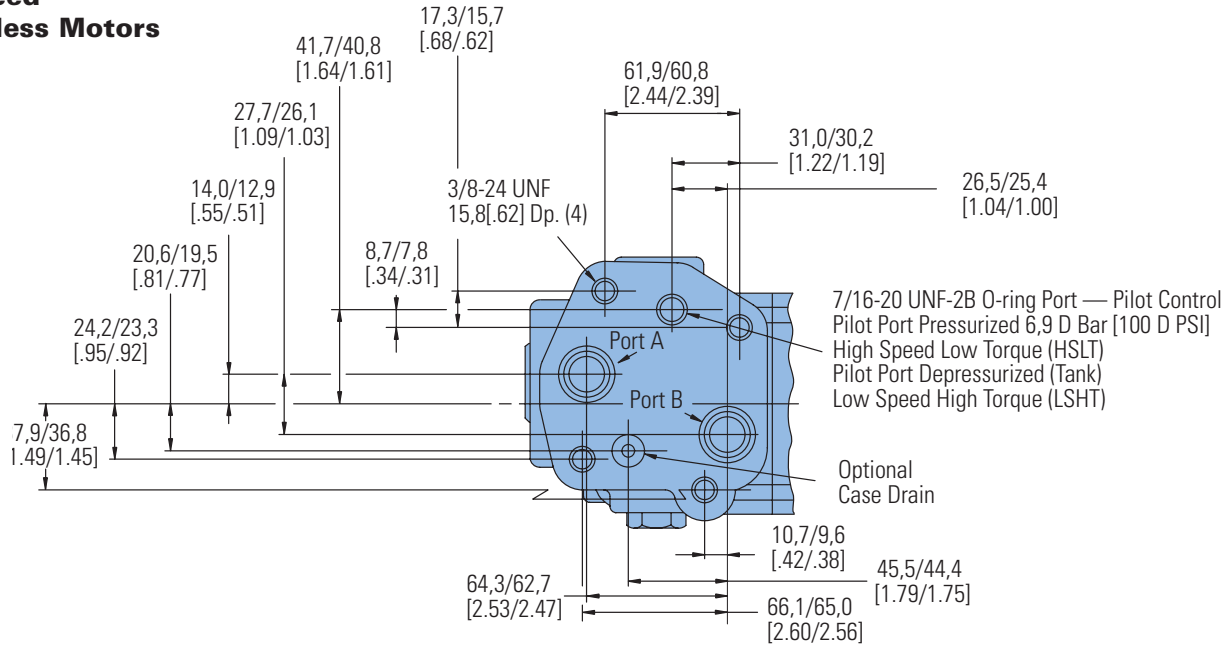

## BEARINGLESS MOTOR DIMENSIONS

Displacement cm <sup>3</sup> /r [in <sup>3</sup> /r]	X mm [inch]	Y mm [inch]
80 [4.9]	79,3 [3.13]	174,0 [6.85]
100 [6.2]	84,1 [3.31]	178,9 [7.04]
130 [8.0]	90,7 [3.57]	185,2 [7.29]
160 [9.6]	90,7 [3.57]	185,2 [7.29]
195 [11.9]	97,3 [3.83]	191,8 [7.55]
245 [14.9]	106,4 [4.19]	201,0 [7.91]
305 [18.7]	117,8 [4.64]	212,4 [8.36]
395 [24.0]	133,6 [5.26]	228,4 [8.99]
490 [29.8]	151,1 [5.95]	245,6 [9.67]

# 2000 Series Two-Speed

## Product Numbers

**Note:**

For 2000 Series Motors with a configuration **Not Shown** in the charts below, contact your Eaton Representative.

Use digit prefix — 193- plus four digit number from charts for complete product number—Example 193-0002.

**Orders will not be accepted without three digit prefix.**

MOUNTING	SHAFT	PORT SIZE	DISPL. cm <sup>3</sup> /r [in <sup>3</sup> /r] / PRODUCT NUMBER								
			80 [4.9]	100 [6.2]	130 [8.0]	160 [9.6]	195 [11.9]	245 [14.9]	305 [18.7]	395 [24.0]	490 [29.8]
2 Bolt SAE A Flange	1 Inch Straight	7/8 -14 O-ring Staggered	193-0002-001	-0003	-0004	-0005	-0006	-0007	-0008	-0009	—
	1 1/4 Inch Straight	7/8 -14 O-ring Staggered	193-0010-001	-0011	-0012	-0013	-0014	-0015	-0016	-0017	-0070
	1 1/4 Inch 14 T Splined	7/8 -14 O-ring Staggered	193-0018-001	-0019	-0020	-0021	-0022	-0023	-0024	-0025	—
Wheel Motor	1 1/4 Inch Tapered	7/8 -14 O-ring Staggered	193-0222-001	-0223	-0224	-0225	-0226	-0227	-0228	-0229	—
	1 1/4 Inch 14 T Splined	7/8 -14 O-ring Staggered	193-0230-001	-0231	-0232	-0233	-0234	-0235	-0236	-0237	—
Bearingless		7/8 -14 O-ring Staggered	193-0282-001	-0283	-0234	-0285	-0286	-0287	-0288	-0289	—

193-0288-001

C-1

# 2000 Series Two-Speed

Model Code (193-)

The following 30-digit coding system has been developed to identify all of the configuration options for the 2000 Series motor. Use this model code to specify a motor with the desired features. All 30 digits of the code must be present when ordering. You may want to photocopy the matrix below to ensure that each number is entered in the correct box.

M	2	2	**	**	**	**	**	*	**	1	*	**	00	**	**	AA	A												
1	2	3	4	5	6	7	8	9	10	11	12	13	14	15	16	17	18	19	20	21	22	23	24	25	26	27	28	29	30

## 1 Product

M – Motor

## 2, 3 Series

22 – 2000 2 Speed Series  
(1:2 Ratio)

## 4, 5, 6 Displacement

049 – 80.6 cm<sup>3</sup>/r [4.92 in<sup>3</sup>/r]  
062 – 101.6 cm<sup>3</sup>/r [6.20 in<sup>3</sup>/r]  
080 – 130.6 cm<sup>3</sup>/r [7.97 in<sup>3</sup>/r]  
096 – 158.1 cm<sup>3</sup>/r [9.65 in<sup>3</sup>/r]  
119 – 194.8 cm<sup>3</sup>/r [11.89 in<sup>3</sup>/r]  
149 – 244.3 cm<sup>3</sup>/r [14.91 in<sup>3</sup>/r]  
187 – 306.6 cm<sup>3</sup>/r [18.71 in<sup>3</sup>/r]  
240 – 393.8 cm<sup>3</sup>/r [24.03 in<sup>3</sup>/r]  
298 – 489.0 cm<sup>3</sup>/r [29.84 in<sup>3</sup>/r]

## 7, 8 Mounting Description

AB – Wheel, 4 Bolt: 108.0 [4.25] Pilot Dia. 13.59 [5.35] Dia. Holes on 147.6 [5.81] Dia. Bolt Circle. 127.0 [5.00] Dia. Rear Mount Pilot

AC – Standard, 2 Bolt: 82.6 [3.25] Pilot Dia. 13.59 [5.35] Dia. Holes on 106.4 [4.19] Dia. Bolt Circle. SAE A

AE – Bearingless (w/ Leakage Slots), 4 Bolt: 101.6 [4.00] Pilot Dia. 13.59 [5.35] Dia. Holes on 127.0 [5.00] Dia. Bolt Circle

AF – Standard, 2 Bolt: 101.6 [4.00] Pilot Dia. 14.35 [5.65] Dia. Holes on 146.0 [5.75] Dia. Bolt Circle. SAE B  
Dia Bolt Circle (European)

## 9, 10 Output Shaft Description

00 – None (Bearingless)  
01 – 25.40 [1.000] Dia. Straight Shaft with 1/4-20UNC-2B Thread in End, 6.35 [.250] Wide x 25.40 [1.000] Dia. Woodruff Key  
02 – 31.75 [1.250] Dia. Straight

Shaft with .375-16UNC-2B Thread in End, 7.938 [.3125] Sq x 31.75 [1.250] Straight Key  
03 – 31.75 [1.250] Dia. .125:1 Tapered Shaft per SAE J501 with/1.000-20 UNEF-2A Threaded Shaft End and Slotted Hex Nut, 7.938 [.3125] Sq x 25.40 [1.0] Straight Key  
04 – 31.75 [1.250] Dia. Flat Root Side Fit, 14 Tooth, 12/24 DP 30° Involute Spline w/ .375-16UNC-2B Thread in End, 33.0 [1.30] Min. Full Spline

## 11, 12 Ports Description

AA – .875-14 UNF-2B SAE O-ring Ports - Staggered Ports  
AB – 12.70 [.500] and 15.88 [.625] Dia. Manifold Ports with 3 x .375-16 UNC-2B Port Block Mounting Holes

## 13, 14 Case Flow Options / Selector Valve

01 – .5625-10 UNF-2B SAE O-Ring Case Drain Port, .4375-20 UNF-2B SAE O-Ring Pilot Control Port, Optional  
.4375-20 UNF-2B SAE Case Drain Port for Pilot Operated Normally Low Speed

## 15 Shuttle Valve / Low Pressure Relief

0 – NONE

## 16, 17 Pressure / Flow Option

00 – NONE

## 18 Geroler Option

1 – STANDARD

## 19 Seal Option

### 00 – Standard Seals

02 – Seal Guard  
03 – Viton Seals

### 04 – Viton Shaft Seal

11 – High pressure shaft seal, slinger seal

### 19 – Extreme duty seal guard

## 20, 21 Accessories

00 – NONE

## 22, 23 Special Features (Hardware)

00 – NONE

## 24, 25 Special Features (Assembly)

00 – NONE

## 26, 27 Paint / Packaging

AA – No Paint, Individual Box  
AB – Low Gloss Black Primer, Individual Box

## 28, 29 Customer Identification

AA – NONE

## 30 Design Code

A – FIRST

# 4000 Compact Series

## Highlights

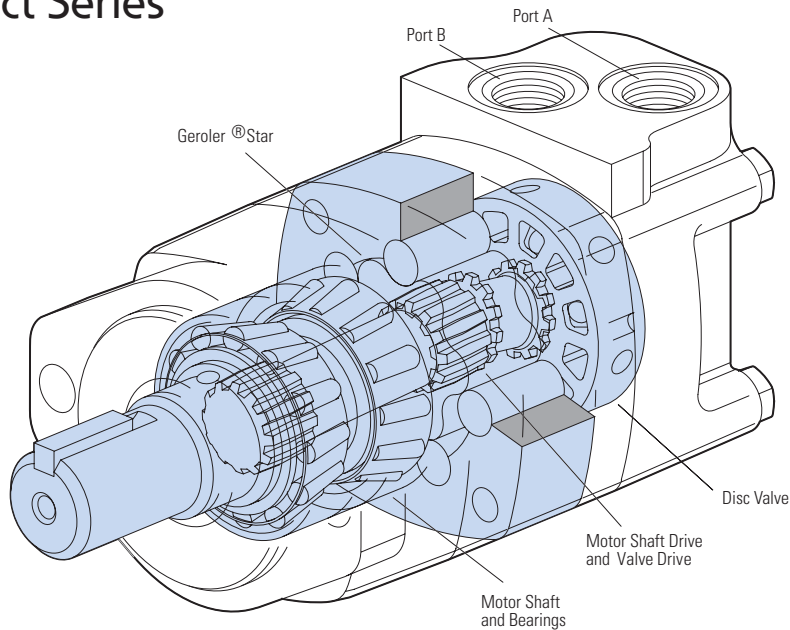

## Features

- Shuttle Valve with Back-Pressure Relief Valve
- Speed Sensors
- End Ports.

## Benefits

- Higher bearing capacity than 2000 Series
- Torque of 4000 Series

## Applications

- Skid Steer Loaders
- Fairway Mowers
- Harvesters
- Vehicles where space may be at a premium.

## Description

This new compact addition in a family of disc valve hydraulic motors produces the same amount of torque as the current 4000 Series. Yet, it is housed in an envelope similar to its smaller counterpart, the 2000 Series. The unit's intermittent torque rating is 1220 Nm [10800 lb-in]. A variety of mounting options include two 2 bolt mounts (SAE A, SAE B), and four 4 bolt mounts (magneto, standard and wheel mounts.) For added flexibility, the motor can be specified with either the larger size shafts of the 2000 Series of standard output shaft sizes of the 4000 Series, plus one new 1-1/2 inch straight (the small envelope and optional shaft sizes make this motor ideal for vehicles like skid-steer loaders whose hallmark is high power and productivity in a small frame.)

## Specifications

Geroler Element	6 Displacements
Flow l/min [GPM]	75 [20] Continuous**
	115 [30] Intermittent*
Speed RPM	464 Cont.**
	699 Inter.*
Pressure bar [PSI]	200 [3000] Cont.**
	300 [4500] Inter.*
Torque Nm [lb-in]	975 [8627] Cont.**
	1218 [10788] Inter.*

\*\* Continuous— (Cont.) Continuous rating, motor may be run continuously at these ratings.

\* Intermittent— (Inter.) Intermittent operation, 10% of every minute.



Lawn and Turf



Skid Steer



Boom Lift



Harvester

# 4000 Compact Series

## Specifications

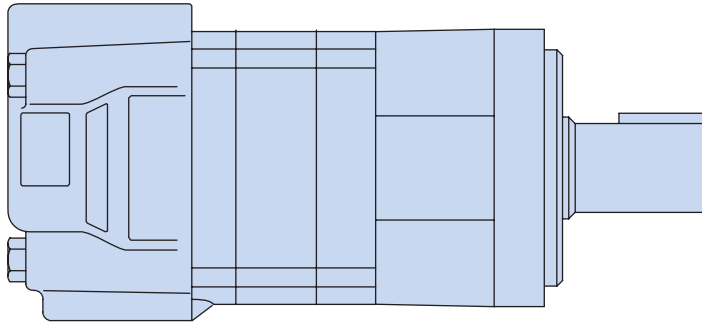

### SPECIFICATION DATA – 4000 COMPACT SERIES MOTORS

Displ. cm <sup>3</sup> /r [in <sup>3</sup> /r]		160 [9.8]	200 [12.3]	250 [15.4]	325 [19.8]	405 [24.6]	490 [29.8]
Max. Speed (RPM) @ Flow	Continuous	464	375	300	234	188	155
	Intermittent	699	562	450	351	282	232
Flow l/min [GPM]	Continuous	75 [20]	75 [20]	75 [20]	75 [20]	75 [20]	75 [20]
	Intermittent	115 [30]	115 [30]	115 [30]	115 [30]	115 [30]	115 [30]
Torque* Nm [lb-in]	Continuous	510 [4514]	758 [5715]	734 [6500]	793 [7021]	800 [7079]	975 [8627]
	Intermittent	690 [6108]	840 [7436]	935 [8272]	1053 [9320]	921 [8153]	1218 [10778]
Pressure Δ bar [Δ PSI]	Continuous	225 [3000]	225 [3000]	205 [3000]	170 [2500]	140 [2000]	140 [2000]
	Intermittent	310 [4500]	295 [4250]	260 [3750]	240 [3500]	170 [2500]	171 [2500]
	Peak	310 [4500]	310 [4500]	310 [4500]	310 [4500]	275 [4000]	260 [3750]
Weight kg [lb]	Standard or Wheel Mount	10,4 [23.0]	10,9 [24.0]	11,3 [25.0]	11,8 [26.0]	12,2 [27.0]	12,2 [27.0]
	Bearingless	8,4 [18.5]	8,8 [19.5]	9,3 [20.5]	9,8 [21.5]	10,2 [22.5]	10,2 [22.5]

Maximum Case Pressure: See case pressure seal limitation graph.

\*See shaft torque ratings for limitations.

#### Note:

To assure best motor life, run motor for approximately one hour at 30% of rated pressure before application to full load. Be sure motor is filled with fluid prior to any load applications.

#### Maximum Inlet Pressure:

310 bar [4500 PSI]  
Do not exceed Δ pressure rating (see chart above).

#### Maximum Return Pressure:

310 bar [4500 PSI] with case drain line installed.  
Do not exceed Δ pressure rating (see chart above).

#### Δ bar [Δ PSI] :

The true pressure difference between inlet port and outlet port

#### Continuous Rating:

Motor may be run continuously at these ratings

#### Intermittent Operation:

10% of every minute

#### Peak Operation:

1% of every minute

#### Recommended Fluids:

Premium quality, anti-wear type hydraulic oil with a viscosity of not less than 70 SUS at operating temperature.

#### Recommended System Operating Temp.:

-34°C to 82°C [-30°F to 180°F]

#### Recommended Filtration:

per ISO Cleanliness Code, 4406: 20/18/13

# 4000 Compact Series

## Performance Data

Motors run with high efficiency in all areas designated with a number for torque and speed. For best motor life select a motor to run with a torque and speed range shown in the light shaded area.

Performance data is typical at 120 SUS. Actual data may vary slightly from unit to unit in production.

	Continuous
	Intermittent
	Peak
	No Operation

		160cm <sup>3</sup> /r [9.8 in <sup>3</sup> /r]																	
		ΔPressure Bar [PSI]																	
		[250]	[500]	[750]	[1000]	[1250]	[1500]	[1750]	[2000]	[2250]	[2500]	[2750]	[3000]	[3250]	[3500]	[3750]	[4000]	[4250]	[4500]
		15	35	50	70	85	105	120	140	155	170	190	205	225	240	260	275	295	310
[0.25]	244	543																	
0,95	28	61																	
[0.5]	4	3																	
1,9	274	554	854																
[1]	31	63	96																
3,8	10	8	7																
[1]	274	593	899	1210	1513	1816	2092	2361	2621	2874	3088								
3,8	31	67	102	137	171	205	236	267	296	325	349								
[2]	22	21	20	19	17	14	12	10	9	7	6								
[2]	301	623	940	1261	1579	1898	2197	2492	2766	3033	3270	3496	3761	4022					
7,5	34	70	106	143	178	214	248	282	313	343	369	395	425	454					
[4]	40	39	38	36	35	33	31	28	24	20	17	14	10	6					
[4]	305	662	1004	1354	1699	2046	2386	2725	3049	3368	3693	4016	4319	4618	4828	5022			
15	34	75	113	153	192	231	270	308	344	381	417	454	488	522	545	567			
[6]	87	85	83	81	79	77	74	72	67	63	59	55	49	44	35	27			
[6]	293	659	1003	1357	1705	2056	2399	2741	3074	3405	3751	4098	4417	4732	5023	5308			
23	33	74	113	153	193	232	271	310	347	385	424	463	499	535	568	600			
[8]	133	131	129	127	124	121	118	114	109	104	99	93	87	80	71	63			
[8]	280	656	1002	1360	1711	2066	2412	2758	3100	3442	3809	4180	4514	4846	5218	5593	5856	6108	
30	32	74	113	154	193	233	273	312	350	389	430	472	510	548	590	632	662	690	
[10]	181	179	177	175	172	169	166	162	157	152	145	139	133	127	120	113	104	96	
[10]	259	630	978	1348	1701	2061	2408	2755	3102	3450	3806	4163	4500	4835	5191	5547	5784		
38	29	71	110	152	192	233	272	311	351	390	430	470	508	546	586	627	653		
[12]	228	225	223	220	217	213	209	204	199	193	186	179	172	165	157	150	141		
[12]	238	604	954	1336	1692	2056	2403	2752	3105	3458	3802	4146	4485	4824	5163	5501			
45	27	68	108	151	191	232	272	311	351	391	430	468	507	545	583	622			
[14]	275	272	269	266	262	258	253	247	241	235	229	223	214	205	197	189			
[14]	210	577	923	1308	1665	2034	2385	2739	3092	3447	3796	4144	4487	4830					
53	24	65	104	148	188	230	269	310	349	390	429	468	507	546					
[16]	322	319	316	313	308	304	298	293	286	279	272	265	256	247					
[16]	182	550	893	1280	1638	2012	2367	2727	3080	3436	3789	4143	4489	4836					
61	21	62	101	145	185	227	267	308	348	388	428	468	507	546					
[18]	370	367	363	360	356	351	345	339	332	324	317	309	301	292					
[18]	143	514	853	1247	1601	1973	2329	2692	3045	3401	3756	4114							
68	16	58	96	141	181	223	263	304	344	384	424	465							
[20]	417	414	410	406	401	397	390	383	375	366	358	350							
[20]	105	478	814	1213	1564	1935	2291	2658	3010	3366	3724	4085							
76	12	54	92	137	177	219	259	300	340	380	421	462							
[22]	464	461	457	453	448	442	435	428	418	409	400	390							
[22]	433	762	1167	1518	1893	2252	2623	2973	3328	3682	4040								
83	49	86	132	172	214	254	296	336	376	416	456								
[24]	508	504	500	495	489	482	474	465	456	446	436								
[24]	387	711	1121	1472	1851	2212	2589	2937	3291	3641	3995								
91	44	80	127	166	209	250	292	332	372	411	451								
[25]	556	552	548	542	537	529	521	513	504	493	483								
[25]	41	77	124	163	206	247	289	329	369										
95	580	576	572	566	560	552	544	535	526										
[30]	244	546	967	1308	1689	2045	2421	2777	3144										
114	28	62	109	148	191	231	274	314	355										
	699	695	692	685	678	669	660	648	637										

[2777]  
314 } Torque [lb-in]  
648 } Nm  
Speed RPM



# 4000 Compact Series

## Performance Data

Motors run with high efficiency in all areas designated with a number for torque and speed. For best motor life select a motor to run with a torque and speed range shown in the light shaded area.

Performance data is typical at 120 SUS. Actual data may vary slightly from unit to unit in production.

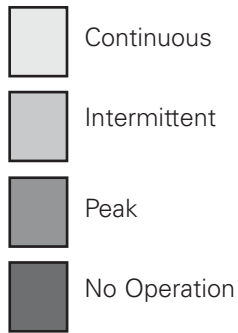

200cm<sup>3</sup>/r [12.3 in<sup>3</sup>/r]  
 ΔPressure Bar [PSI]

	[250] 15	[500] 35	[750] 50	[1000] 70	[1250] 85	[1500] 105	[1750] 120	[2000] 140	[2250] 155	[2500] 170	[2750] 190	[3000] 205	[3250] 225	[3500] 240	[3750] 260	[4000] 275	[4250] 295
[0.25]	115	504															
0.95	13	57															
[0.5]	4	3															
1.9	268	584	963	1274													
[1]	30	66	109	144													
3.8	8	7	4	3													
[2]	306	721	1104	1516	1913	2243	2397	2772									
7.5	35	81	125	171	216	253	271	313									
[4]	17	16	14	13	12	10	9	6									
15	402	841	1218	1647	2107	2478	2826	3238	3954	4451	4755	5127	5407	5569	5855		
[6]	45	95	138	186	238	280	319	366	447	503	537	579	611	629	662		
23	35	34	32	31	30	28	27	24	29	26	23	21	17	11	8		
[8]	403	896	1361	1780	2247	2649	3068	3513	3947	4367	4710	5125	5509	5880	6249	6547	6753
30	46	101	154	201	254	299	347	397	446	493	532	579	622	664	706	740	763
[10]	72	70	69	68	66	65	62	60	56	53	50	46	42	37	31	24	19
38	385	863	1354	1785	2260	2657	3087	3547	3965	4389	4793	5218	5610	6015	6408	6754	7436
[12]	44	98	153	202	255	300	349	401	448	496	542	590	634	680	724	763	840
45	109	107	106	104	102	100	97	93	90	86	81	77	72	66	60	52	47
[14]	368	831	1347	1790	2273	2665	3106	3581	3982		4876	5311	5712	6151	6567	6961	7334
53	42	94	152	202	257	301	351	405	450	498	551	600	645	695	742	786	829
[16]	147	146	144	142	140	137	134	130	127	122	117	113	108	103	98	91	83
61	353	822	1319	1774	2212	2642	3086	3556	3974	4410	4839	5297	5715	6147	6563		
[18]	40	93	149	200	250	299	349	402	449	498	547	598	646	695	742		
68	185	184	181	179	177	174	170	165	161	156	151	146	140	134	129		
[20]	339	813	1291	1758	2151	2620	3067	3530	3965	4408	4802	5283	5718	6144	6568		
76	38	92	146	199	243	296	346	399	448	498	543	597	646	694	742		
[22]	223	222	219	217	214	211	207	202	197	192	186	180	174	167	164		
83	282	762	1237	1693	2121	2601	2968	3504	3953	4368	4832	5261	5690				
[24]	32	86	140	191	240	294	335	396	447	493	546	594	643				
91	261	260	257	255	252	248	244	238	233	227	221	214	208				
[25]	224	712	1183	1629	2091	2581	2870	3477	3940	4328	4861	5240	5661				
95	25	80	134	184	236	292	324	393	445	489	549	592	640				
[30]	299	298	296	293	290	286	282	275	269	263	256	249	243				
114	200	667	1148	1619	2053	2520	2899	3442	3906	4337	4819	5245	5644				
[30]	23	75	130	183	232	285	328	389	441	490	544	593	638				
[30]	337	336	334	331	328	324	320	314	307	301	293	285	278				
[30]	176	623	1112	1609	2014	2458	2929	3407	3872	4347	4777	5250	5627				
[30]	20	70	126	182	228	278	331	385	437	491	540	593	636				
[30]	375	374	372	369	366	363	358	353	346	339	331	322	315				
[30]		565	1053	1530	1934	2387	2868	3347	3804	4254	4698						
[30]		64	119	173	219	270	324	378	430	481	531						
[30]		412	410	407	404	401	396	390	383	375	367						
[30]		507	994	1450	1855	2316	2806	3287	3737	4162	4618						
[30]		57	112	164	210	262	317	371	422	470	522						
[30]		449	448	446	443	439	434	427	420	412	403						
[30]		465	950	1411	1820	2276	2768	3233	3688	4116	4493						
[30]		53	107	159	206	257	313	365	417	465	508						
[30]		468	467	464	462	458	453	446	439	431	423						
[30]		259	726	1214	1645	2072	2577	2961	3443	3889	3866						
[30]		29	82	137	186	234	291	335	389	439	437						
[30]		562	563	559	555	556	550	545	536	527	521						

[2072] } Torque [lb-in]  
 234 } Nm  
 556 } Speed RPM

# 4000 Compact Series

## Performance Data

Motors run with high efficiency in all areas designated with a number for torque and speed. For best motor life select a motor to run with a torque and speed range shown in the light shaded area.

Performance data is typical at 120 SUS. Actual data may vary slightly from unit to unit in production.

	Continuous
	Intermittent
	Peak
	No Operation

250cm<sup>3</sup>/r [15.4 in<sup>3</sup>/r]  
ΔPressure Bar [PSI]

	[250] 15	[500] 35	[750] 50	[1000] 70	[1250] 85	[1500] 105	[1750] 120	[2000] 140	[2250] 155	[2500] 170	[2750] 190	[3000] 205	[3250] 225	[3500] 240	[3750] 260
[0.5]	384	833													
1,9	43	94													
[1]	6	5													
3,8	438	904	1403	1887	2359	2798	3221	3657	3822	4326					
	49	102	158	213	267	316	364	413	432	489					
[2]	14	14	13	12	11	9	8	7	4	3					
7,5	492	1054	1563	2081	2623	3160	3717	4147	4585	5070	5470	5721	5962		
	56	119	177	235	296	357	420	469	518	573	618	646	674		
[4]	28	27	26	25	24	23	21	17	16	13	9	7	5		
15	603	1183	1771	2275	2817	3364	3895	4495	5005	5496	5982	6500	7054	7519	7941
	68	134	200	257	318	380	440	508	565	621	676	734	797	850	897
[6]	58	56	55	54	52	50	47	44	42	38	35	32	28	24	17
23	587	1159	1741	2329	2815	3369	3951	4483	5021	5555	6068	6557	7131	7641	8107
	66	131	197	263	318	381	446	506	567	628	686	741	806	863	916
[8]	88	86	84	82	80	77	74	71	67	63	59	55	50	45	38
30	571	1135	1710	2384	2813	3375	4008	4471	5038	5613	6154	6614	7209	7763	8272
	65	128	193	269	318	381	453	505	569	634	695	747	815	877	935
[10]	118	116	114	112	110	107	103	100	96	92	87	83	78	73	67
38	552	1138	1671	2304	2804	3361	3950	4452	5006	5587	6123	6612	7201		
	62	129	189	260	317	380	446	503	566	631	692	747	814		
[12]	148	146	144	142	139	136	131	127	123	119	113	109	102		
45	532	1140	1631	2224	2796	3347	3892	4434	4974	5561	6093	6610	7193		
	60	129	184	251	316	378	440	501	562	628	688	747	813		
[14]	178	177	175	173	170	166	161	157	151	146	141	136	129		
53	441	1072	1600	2207	2754	3320	3888	4433	4958	5529	6066	6590			
	50	121	181	249	311	375	439	501	560	625	685	745			
[16]	209	207	205	202	199	195	190	185	179	174	168	162			
61	349	1003	1568	2190	2711	3292	3884	4431	4941	5496	6039	6570			
	39	113	177	247	306	372	439	501	558	621	682	742			
[18]	239	237	235	233	229	225	220	214	208	202	195	189			
68	306	940	1513	2114	2653	3251	3830	4380	4904	5446	5984	6518			
	35	106	171	239	300	367	433	495	554	615	676	736			
[20]	269	267	265	263	259	255	250	243	236	230	223	214			
76	263	876	1458	2038	2595	3210	3777	4328	4867	5395	5928	6471			
	30	99	165	230	293	363	427	489	550	610	670	731			
[22]	300	298	296	293	290	285	280	272	265	259	251	241			
83		826	1414	1991	2528	3144	3709	4262	4806	5354	5915				
		93	160	225	286	355	419	482	543	605	668				
[24]		328	326	323	320	315	309	302	295	288	279				
91		776	1370	1945	2462	3079	3642	4196	4745	5313	5901				
		88	155	220	278	348	411	474	536	600	667				
[25]		359	356	354	350	345	339	332	325	317	308				
95		732	1322	1959	2426	3026	3594	4153	4696	5152					
		83	149	221	274	342	406	469	531	582					
[30]		374	371	369	365	360	354	347	340	333					
114		509	1082	2029	2246	2761	3358	3939	4450	4347					
		57	122	229	254	312	379	445	503	491					
		450	449	445	442	437	430	423	414	413					

[2246]  
254  
442 } Torque [lb-in]  
Nm  
Speed RPM

# 4000 Compact Series

## Performance Data

Motors run with high efficiency in all areas designated with a number for torque and speed. For best motor life select a motor to run with a torque and speed range shown in the light shaded area.

Performance data is typical at 120 SUS. Actual data may vary slightly from unit to unit in production.

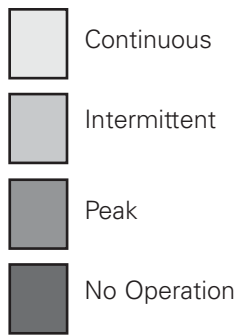

		<b>325cm<sup>3</sup>/r [19.8 in<sup>3</sup>/r]</b>													
		<b>ΔPressure Bar [PSI]</b>													
		[250]	[500]	[750]	[1000]	[1250]	[1500]	[1750]	[2000]	[2250]	[2500]	[2750]	[3000]	[3250]	[3500]
		15	35	50	70	85	105	120	140	155	170	190	205	225	240
[0.5]	536	1152													
1,9	61	130													
[1]	5	4													
3,8	555	1220	1900	2559	3222	3862	4522	5061	5580	6106					
[2]	63	138	215	289	364	436	511	572	630	690					
7,5	11	10	10	9	9	8	7	5	3	3					
[4]	643	1349	2025	2712	3378	4051	4696	5335	5889	6366	6876				
15	73	152	229	306	382	458	531	603	665	719	777				
[6]	22	21	20	19	19	17	15	13	10	5	3				
23	679	1420	2140	2852	3557	4259	4947	5628	6300	6960	7596	8201	8767	9320	
[8]	77	160	242	322	402	481	559	636	712	786	858	927	991	1053	
30	45	44	43	42	40	38	36	33	30	26	23	19	14	11	
[10]	654	1400	2132	2859	3575	4281	4977	5668	6346	7021	7678	8244	8792		
38	74	158	241	323	404	484	562	640	717	793	868	931	993		
[12]	68	67	66	64	62	59	56	53	49	44	40	38	35		
45	629	1379	2125	2866	3592	4304	5007	5707	6392	7082	7760	8400			
[14]	71	156	240	324	406	486	566	645	722	800	877	949			
53	92	90	89	87	85	82	79	75	71	66	61	56			
[16]	587	1337	2082	2827	3556	4272	4976	5672	6362	7053					
61	66	151	235	319	402	483	562	641	719	797					
[18]	115	114	112	110	107	103	100	94	90	85					
68	546	1295	2040	2787	3520	4240	4944	5638	6332	7023					
[20]	62	146	230	315	398	479	559	637	715	794					
76	139	137	136	134	130	125	121	115	110	105					
[22]	489	1238	1984	2729	3467	4193	4903	5600	6293						
83	55	140	224	308	392	474	554	633	711						
[24]	162	161	159	157	153	148	143	136	131						
91	431	1182	1929	2671	3415	4145	4861	5562	6254						
[25]	49	134	218	302	386	468	549	628	707						
95	186	185	183	181	177	171	165	159	153						
[30]	360	1110	1856	2600	3343	4073	4794	5499							
114	41	125	210	294	378	460	542	621							
	210	208	206	204	200	195	189	183							
	288	1038	1784	2529	3271	4001	4726	5436							
	33	117	202	286	370	452	534	614							
	234	232	230	228	224	220	214	207							
		958	1706	2451	3194	3926	4650	5360							
		108	193	277	361	444	525	606							
		256	254	251	248	243	237	229							
		878	1628	2373	3116	3850	4574	5285							
		99	184	268	352	435	517	597							
		279	277	275	271	266	260	252							
		826	1576	2320	3063	3798	4523								
		93	178	262	346	429	511								
		291	289	287	283	277	271								
		566	1314	2056	2799	3536	4268								
		64	148	232	316	399	482								
		351	349	346	342	337	332								

[2799] } Torque [lb-in]  
 316 } Nm  
 342 } Speed RPM

# 4000 Compact Series

## Performance Data

Motors run with high efficiency in all areas designated with a number for torque and speed. For best motor life select a motor to run with a torque and speed range shown in the light shaded area.

Performance data is typical at 120 SUS. Actual data may vary slightly from unit to unit in production.

	Continuous
	Intermittent
	Peak
	No Operation

405cm<sup>3</sup>/r [24.6 in<sup>3</sup>/r]  
ΔPressure Bar [PSI]

	[250]	[500]	[750]	[1000]	[1250]	[1500]	[1750]	[2000]	[2250]	[2500]
	15	35	50	70	85	105	120	140	155	170
[0.5]	719	1458								
1,9	81	165								
	3	2								
[1]	777	1631	2423	3148	3690					
3,8	88	184	274	356	417					
	8	7	5	4	3					
[2]	853	1812	2596	3375	4179	4845	5375	5841	6501	
7,5	96	205	293	381	472	547	607	660	735	
	17	15	14	12	11	9	8	3	2	
[4]	878	1859	2687	3667	4554	5388	6232	7004	7660	8153
15	99	210	304	414	515	609	704	791	865	921
	35	34	32	30	28	25	23	19	16	11
[6]	882	1836	2716	3680	4577	5388	6269	7079	7856	
23	100	207	307	416	517	609	708	800	888	
	54	52	51	48	46	42	39	35	31	
[8]	885	1813	2746	3694	4600	5388	6307	7153	8052	
30	100	205	310	417	520	609	713	808	910	
	73	72	70	68	65	62	58	55	50	
[10]	810	1736	2693	3639	4540	5390	6310	7151	7994	
38	92	196	304	411	513	609	713	808	903	
	92	90	89	86	84	80	75	71	67	
[12]	735	1660	2640	3584	4480	5391	6314	7149		
45	83	188	298	405	506	609	713	808		
	111	110	108	106	103	98	93	88		
[14]	661	1622	2560	3512	4412	5330	6242	7059		
53	75	183	289	397	498	602	705	798		
	130	128	127	124	121	117	112	108		
[16]	587	1585	2480	3440	4343	5268	6170			
61	66	179	280	389	491	595	697			
	149	147	146	143	141	137	131			
[18]	492	1472	2379	3333	4270	5190	6084			
68	56	166	269	377	482	586	687			
	168	167	165	162	160	156	150			
[20]	397	1359	2279	3226	4197	5112	5999			
76	45	153	257	365	474	578	678			
	188	186	184	182	179	175	170			
[22]		1264	2194	3124	4093	5008	5904			
83		143	248	353	462	566	667			
		205	203	201	198	193	188			
[24]		1169	2110	3023	3989	4904	5810			
91		132	238	342	451	554	656			
		224	222	220	216	212	207			
[25]		1106	2049	2961	3929	4851	5766			
95		125	231	335	444	548	651			
		233	232	229	226	222	217			
[30]		790	1744	2655	3634	4587	5543			
114		89	197	300	411	518	626			
		282	280	277	274	270	266			

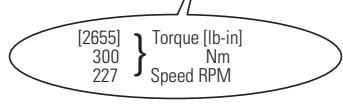





# 4000 Compact Series

## Performance Data

Motors run with high efficiency in all areas designated with a number for torque and speed. For best motor life select a motor to run with a torque and speed range shown in the light shaded area.

Performance data is typical at 120 SUS. Actual data may vary slightly from unit to unit in production.

	Continuous
	Intermittent
	Peak
	No Operation

Flow LPM [GPM]

490cm<sup>3</sup>/r [29.8 in<sup>3</sup>/r]  
ΔPressure Bar [PSI]

	[250] 15	[500] 35	[750] 50	[1000] 70	[1250] 85	[1500] 105	[1750] 120	[2000] 140	[2250] 155	[2500] 170
[0.5] 1,9	375 42 3	1669 189 3								
[1] 3,8	525 59 7	1762 199 7	2945 333 6	3965 448 6	5099 576 6	5926 670 5	6715 759 4	7503 848 3		
[2] 7,5	639 72 14	2108 238 14	3287 371 13	4169 471 13	5416 612 11	6570 742 11	7188 812 9	8295 937 6	8959 1012 5	
[4] 15	981 111 30	2201 249 29	3333 377 29	4574 517 28	5558 628 27	6634 750 26	7694 869 24	8627 975 21	9567 1081 18	10399 1175 13
[6] 23	1049 119 45	2218 251 45	3332 376 44	4584 518 43	5604 633 42	6670 754 40	7711 871 38	8713 984 35	9698 1096 31	10588 1196 26
[8] 30	1118 126 61	2236 253 60	3331 376 60	4593 519 59	5650 638 58	6705 758 56	7727 873 54	8798 994 51	9828 1110 48	10778 1218 44
[10] 38	1060 120 76	2230 252 76	3304 373 75	4503 509 75	5607 633 73	6693 756 72	7721 872 69	8836 998 66		
[12] 45	1003 113 92	2223 251 91	3276 370 91	4413 499 90	5564 629 89	6680 755 88	7715 872 85	8874 1003 82		
[14] 53	858 97 108	2127 240 107	3136 354 107	4320 488 106	5496 621 105	6542 739 103	7653 865 100			
[16] 61	713 81 124	2030 229 123	2997 339 122	4226 477 122	5428 613 121	6403 723 119	7590 858 115			
[18] 68	631 71 139	1907 215 139	2935 332 138	4133 467 137	5330 602 136	6339 716 134	7431 840 130			
[20] 76	548 62 155	1784 202 154	2872 325 153	4041 457 153	5232 591 152	6275 709 150	7362 832 148			
[22] 83		1669 189 170	2704 306 169	3928 444 168	5048 570 168	6124 692 166	7208 814 164			
[24] 91		1553 175 186	2536 287 185	3816 431 185	4864 550 184	5972 675 182	7055 797 179			
[25] 95		1469 166 193	2475 280 193	3737 422 193	4810 543 192	5909 668 190	6959 786 187			
[30] 114		1047 118 232	2172 245 232	3341 378 232	4538 513 231	5592 632 229	6482 732 227			

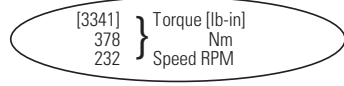

# 4000 Compact Series

## Dimensions

### Standard Mount

### Ports

- 7/8 -14 UNF-2B SAE O-ring Staggered Ports (2)
- 7/16 -20 UNF-2B SAE O-ring Case Drain Port (1) or
- 1 1/16 -12 UN-2B SAE O-ring Ports (Positioned 180° Apart) (2)
- 7/16 -20 UNF-2B SAE O-ring Case Drain Port (1) or
- 7/8 -14 UNF-2B SAE O-ring End Ports (2)
- 7/16 -20 UNF-2B SAE O-ring Case Drain Port (1) or
- G 1/2 (BSP) Staggered Ports (2)
- G 1/4 (BSP) Case Drain Port (1) or
- Manifold Mount
- 7/16 -20 UNF-2B SAE O-ring Case Drain Port (1)

### Standard Rotation Viewed from Shaft End

- Port A Pressurized — CW
- Port B Pressurized — CCW

### Standard Mount

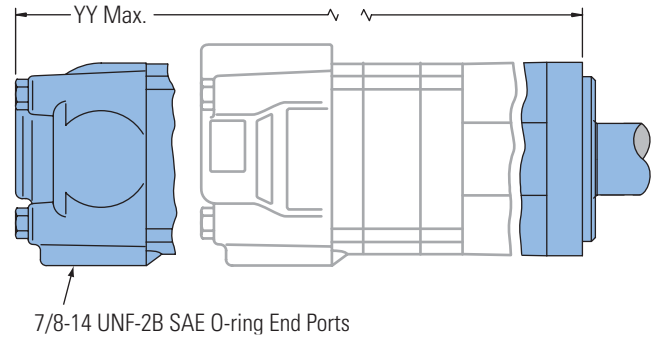
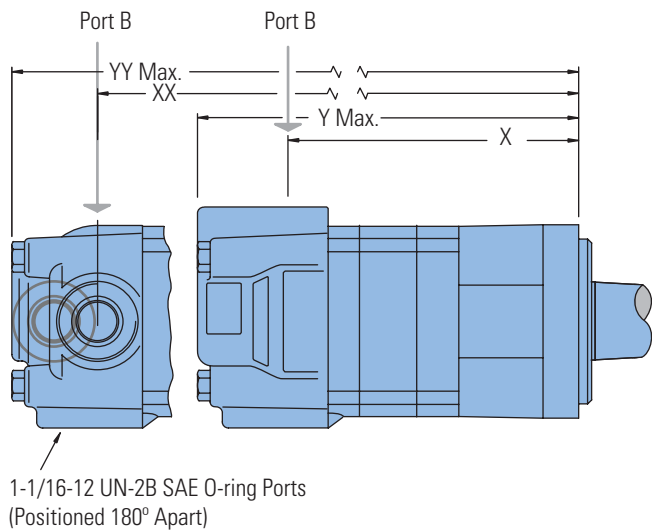

C-2

### STANDARD MOUNT MOTOR DIMENSIONS

Displacement	X	Y	XX	YY
cm <sup>3</sup> /r [in <sup>3</sup> /r]	mm [inch]	mm [inch]	mm [inch]	mm [inch]
160 [9.8]	154,7 [6.09]	201,9 [7.95]	157,0 [6.18]	203,3 [8.00]
200 [12.3]	163,8 [6.45]	211,1 [8.31]	166,1 [6.54]	212,3 [8.36]
250 [15.4]	175,3 [6.90]	222,5 [8.76]	177,5 [6.99]	223,8 [8.81]
325 [19.8]	191,0 [7.52]	238,5 [9.39]	193,3 [7.61]	239,8 [9.44]
405 [24.6]	208,5 [8.21]	255,8 [10.07]	210,8 [8.30]	257,0 [10.12]
490 [29.8]	208,5 [8.21]	255,8 [10.07]	210,8 [8.30]	257,0 [10.12]

# 4000 Compact Series

## Dimensions

### Wheel Mount

## Ports

- 7/8 -14 UNF-2B SAE O-ring Staggered Ports (2)
- 7/16 -20 UNF-2B SAE O-ring Case Drain Port (1) or
- 1 1/16 -12 UN-2B SAE O-ring Ports (Positioned 180° Apart) (2)
- 7/16 -20 UNF-2B SAE O-ring Case Drain Port (1) or
- 7/8 -14 UNF-2B SAE O-ring End Ports (2)
- 7/16 -20 UNF-2B SAE O-ring Case Drain Port (1) or
- G 1/2 (BSP) Staggered Ports (2)
- G 1/4 (BSP) Case Drain Port (1) or
- Manifold Mount
- 7/16 -20 UNF-2B SAE O-ring Case Drain Port (1)

## Standard Rotation Viewed from Shaft End

- Port A Pressurized — CW
- Port B Pressurized — CCW

## Wheel Mount

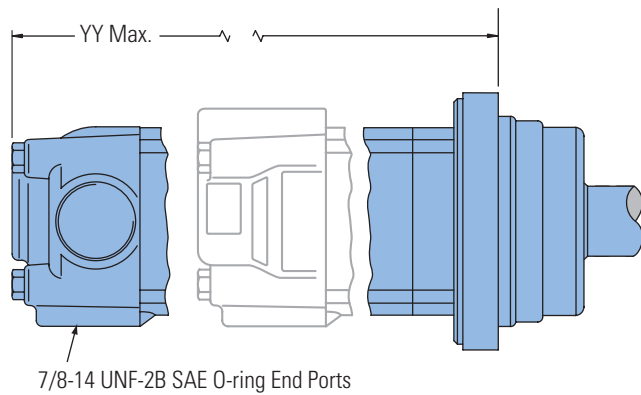
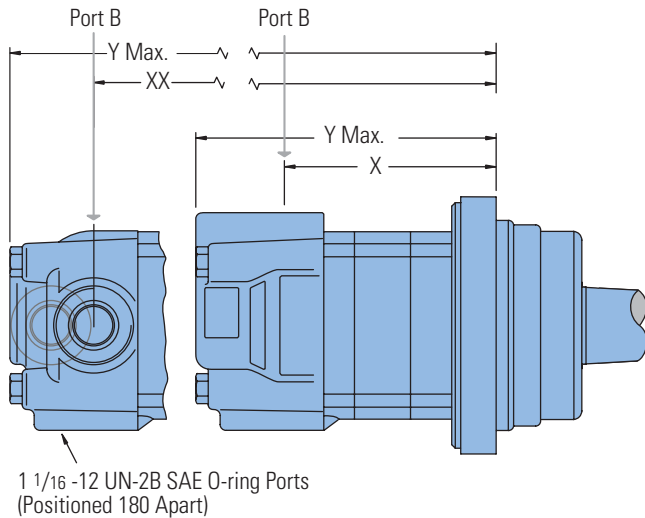

## WHEEL MOUNT MOTOR DIMENSIONS

Displacement	X	Y	XX	YY
cm <sup>3</sup> /r [in <sup>3</sup> /r]	mm [inch]	mm [inch]	mm [inch]	mm [inch]
160 [9.8]	114,6 [4.51]	161,8 [6.37]	114,6 [4.51]	161,8 [6.37]
200 [12.3]	123,7 [4.87]	170,9 [6.73]	123,7 [4.87]	170,9 [6.73]
250 [15.4]	135,1 [5.32]	182,4 [7.18]	135,1 [5.32]	182,4 [7.18]
325 [19.8]	150,9 [5.94]	198,4 [7.81]	150,9 [5.94]	198,4 [7.81]
405 [24.6]	168,4 [6.63]	215,6 [8.49]	168,4 [6.63]	215,6 [8.49]
490 [29.8]	168,4 [6.63]	215,6 [8.49]	168,4 [6.63]	215,6 [8.49]

# 4000 Compact Series

Dimensions

Bearingless

## Ports

- 7/8 -14 UNF-2B SAE O-ring Staggered Ports (2)
- 7/16 -20 UNF-2B SAE O-ring Case Drain Port (1) or
- 1 1/16 -12 UN-2B SAE O-ring Ports (Positioned 180° Apart) (2)
- 7/16 -20 UNF-2B SAE O-ring Case Drain Port (1) or
- 7/8 -14 UNF-2B SAE O-ring End Ports (2)
- 7/16 -20 UNF-2B SAE O-ring Case Drain Port (1) or
- G 1/2 (BSP) Staggered Ports (2)
- G 1/4 (BSP) Case Drain Port (1) or
- Manifold Mount
- 7/16 -20 UNF-2B SAE O-ring Case Drain Port (1)

## Standard Rotation Viewed from Shaft End

- Port A Pressurized — CW
- Port B Pressurized — CCW

## Bearingless

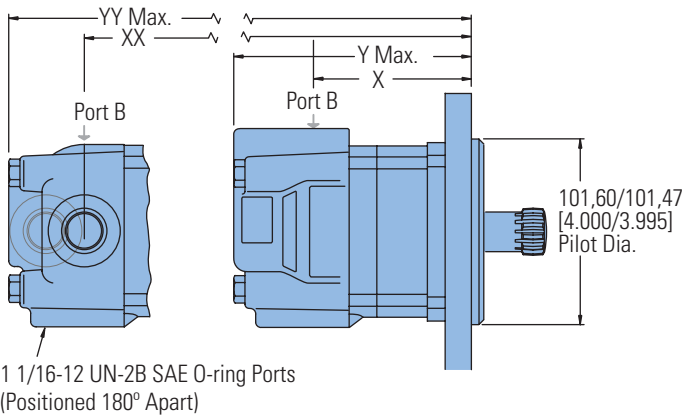

For 4000 bearingless motor application information, contact your Eaton representative (mating coupling blanks available from Eaton Hydraulics).

### Note:

After machining blank, part must be hardened per Eaton specification.

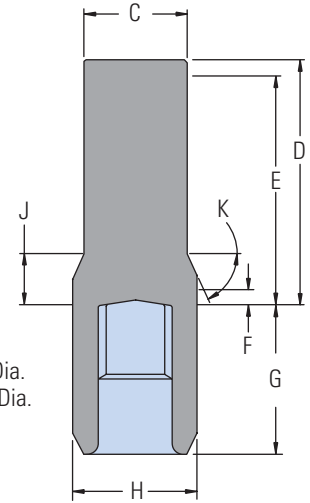

- C 47,2 [1.86] Dia.
- D 112,5 [4.43] Max.
- E 107,4 [4.23] Full Form Dia.
- F 7,4 [.29] Min. Full Form Dia.
- G 68,8 [2.71] Max.
- H 56,9 [2.24] Dia.
- J 18,29 [.720]
- K 38°

Mating Coupling Blank  
Eaton Part No. 12745-003

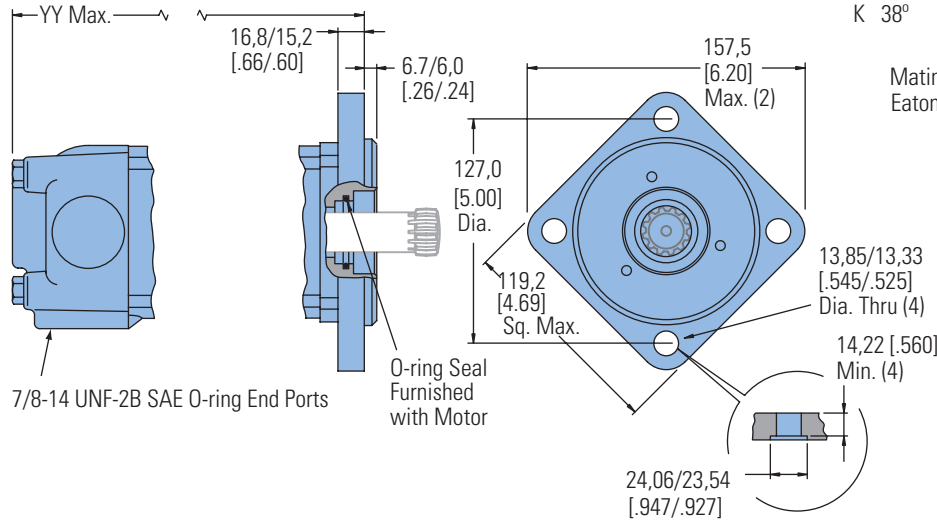
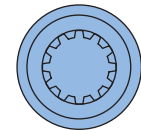

## BEARINGLESS MOTOR DIMENSIONS

Displacement	X	Y	XX	YY
cm <sup>3</sup> /r [in <sup>3</sup> /r]	mm [inch]	mm [inch]	mm [inch]	mm [inch]
160 [9.8]	96,8 [3.81]	144,3 [5.68]	99,1 [3.90]	145,5 [5.73]
200 [12.3]	105,7 [4.16]	153,4 [6.04]	108,0 [4.25]	154,7 [6.09]
250 [15.4]	117,1 [4.61]	164,8 [6.49]	119,4 [4.70]	166,1 [6.54]
325 [19.8]	133,1 [5.24]	180,8 [7.12]	135,4 [5.33]	182,1 [7.17]
405 [24.6]	150,4 [5.92]	198,1 [7.80]	152,7 [6.01]	199,4 [7.85]
490 [29.8]	150,4 [5.92]	198,1 [7.80]	152,7 [6.01]	199,4 [7.85]



# 4000 Compact Series

## Installation Information

### Bearingless

- 1 Internal spline in mating part to be per spline data specification. Material to be ASTM A304, 8620H vacuum degassed alloy steel carbonize to a hardness of 59-62 HRc with case depth (to 50HRc) of 0,76 - 1,02 [.030 - .040] dimensions apply after heat treat.
- 2 Mating part to have critical dimensions as shown. Oil holes must be provided and open for proper oil circulation.
- 3 Seal to be furnished with motor for proper oil circulation thru splines.
- 4 Some means of maintaining clearance between shaft and mounting flange must be provided.
- 5 Counterbore designed to adapt to a standard sleeve bearing 50,010 - 50,040 [1.9689 - 1.9700] ID by 60,050 - 60,080 [2.3642 - 2.3653] (Oilite bronze sleeve bearing) Source: Beemer Precision Inc. www.oilite.com, 1-800-836-2340 AAM 50 mm ID - 60 mm OD Length Determined by the Customer.  
Stock Bearing Lengths:  
35 mm  
50 mm  
60 mm  
70 mm  
75 mm

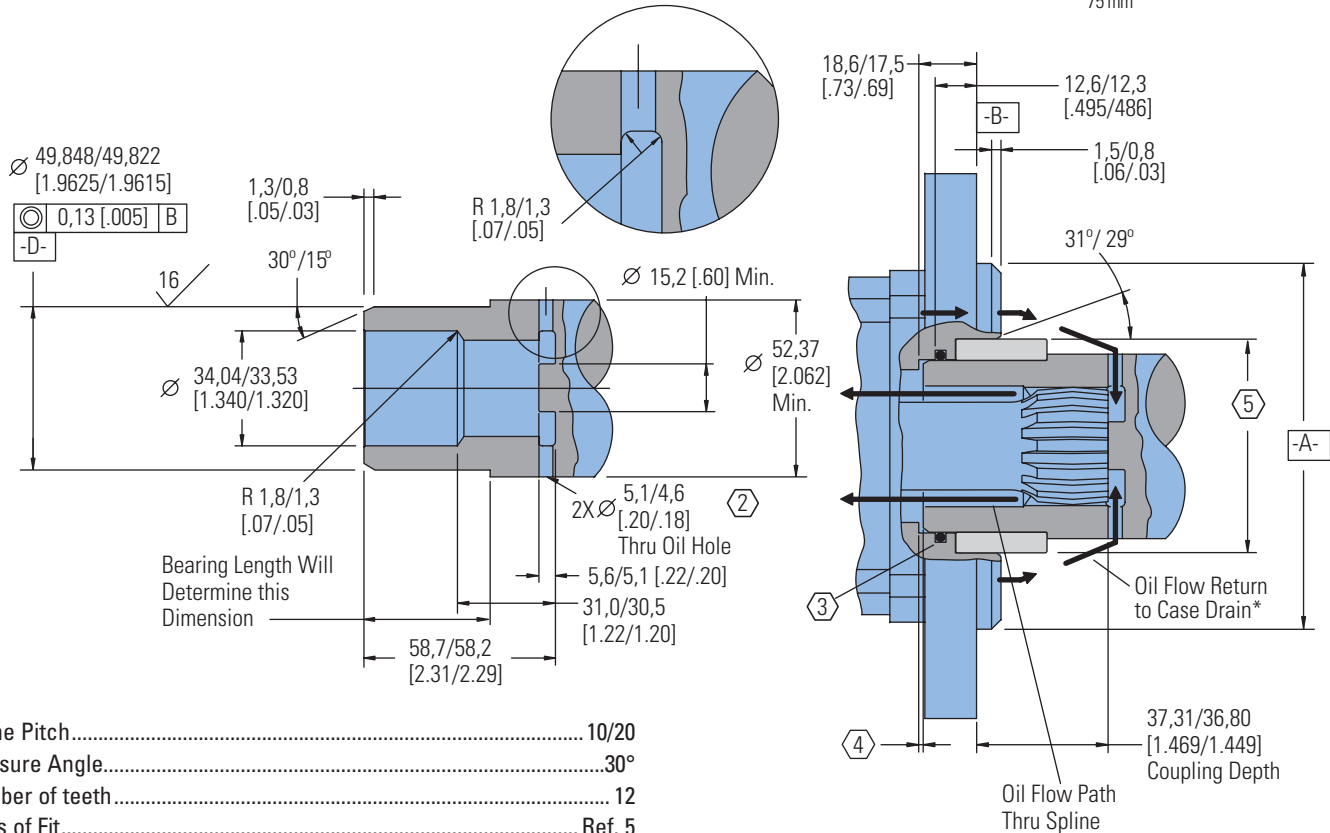

Spline Pitch.....	10/20
Pressure Angle.....	30°
Number of teeth.....	12
Class of Fit.....	Ref. 5
Type of Fit.....	Side
Pitch Diameter.....	Ref. 30,480000 [1.2000000] $\nearrow$ 0,20 [0.008] D
Base Diameter.....	Ref. 26,396455 [1.0392305]
Major Diameter.....	(33,43 [1.316] Max. 33,23 [1.308] Min.)
Minor Diameter.....	28,40 - 25,58 [1.118 - 1.125]
Form Diameter, Min.....	32,59 [1.283]
Fillet Radius.....	0,63 - 0,76 [0.025 - .030]
Tip Radius.....	0,26 - 0,51 [0.010 - .020]
Finish.....	1,6 (63)
Involute Profile Variation.....	+0,000 -0,025 [+0.0000 -0.0010]
Total Index Variation.....	0,038 [0.0015]
Lead Variation.....	0,013 [0.0005]
Circular Space Width:	
Maximum Actual.....	5,045 [1.986]
Minimum Effective.....	4,995 [1.951]
Maximum Effective.....	Ref. 5,009 [1.972]
Minimum Actual.....	Ref. 4,986 [1.963]
Dimension Between Two Pins.....	Ref. 22,783 - 22,929 [0.8970 - .9027]
Pin Diameter.....	5,334 [0.2100] Pins to Have 3,73 [0.147]

Wide Flat for Root Clearance

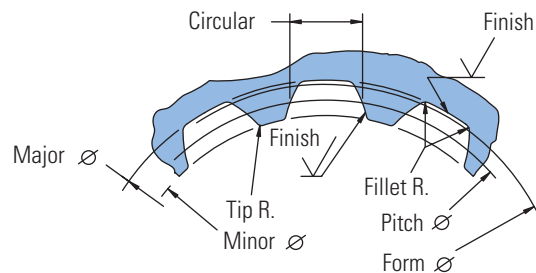

# 4000 Compact Series

## Dimensions

### Mounting Options

#### SAE A – Two Bolt (Standard Motor)

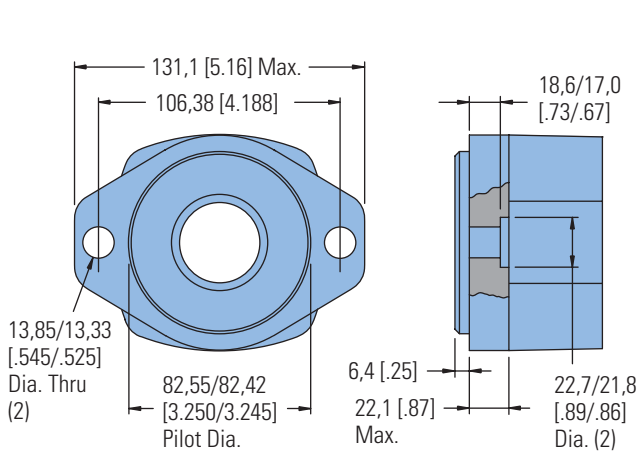

#### Four Bolt Magneto

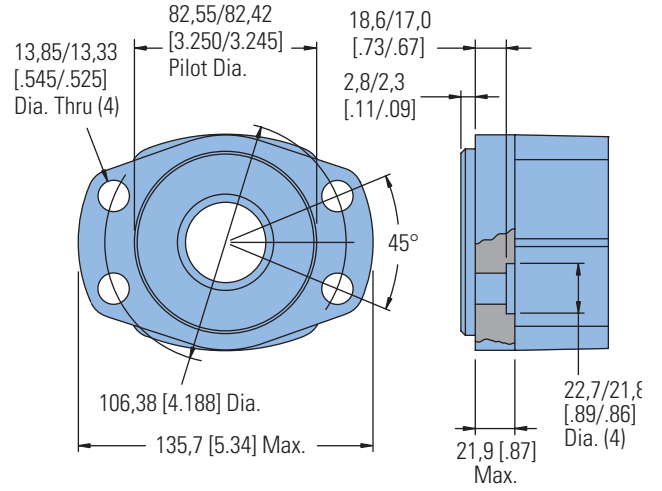

#### Two Bolt SAE B

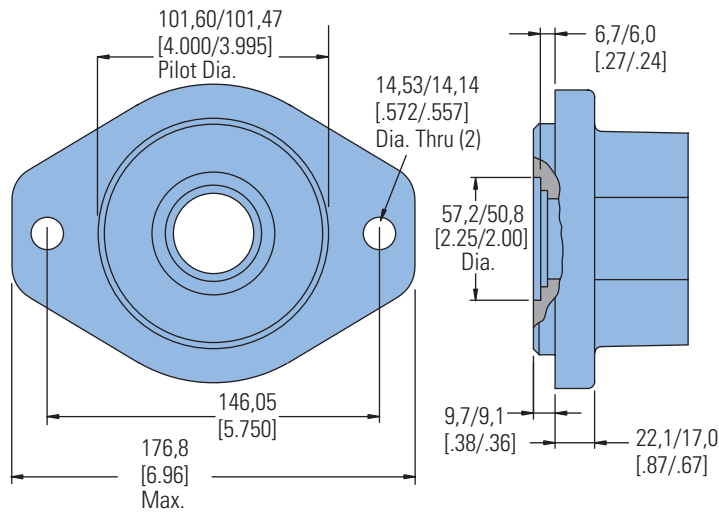

#### Four Bolt

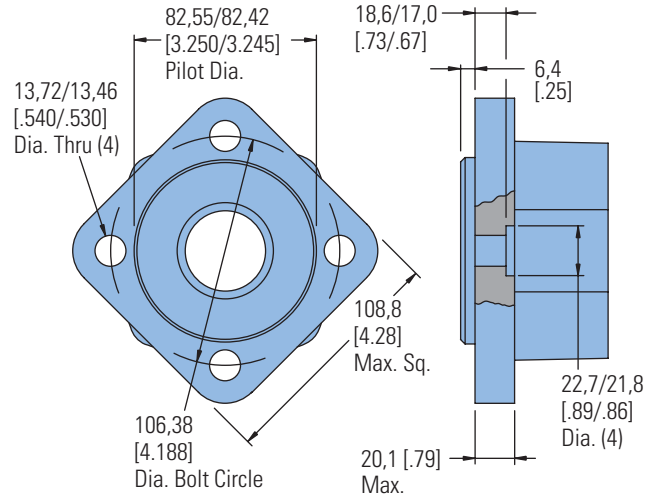

#### Four Bolt (Wheel Motor)

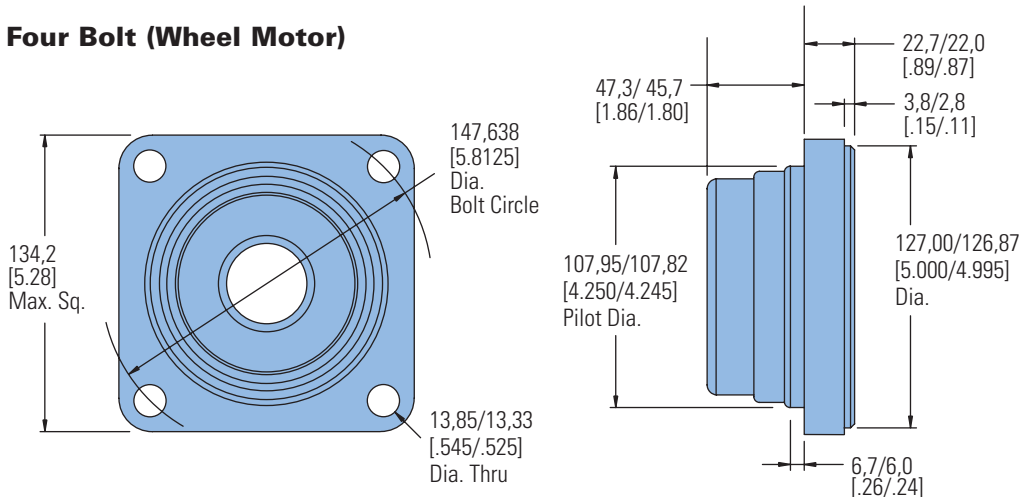

C-2

# 4000 Compact Series

## Dimensions

Mounting Options for use with Enhanced Bearings

### Standard Flange- Similar to SAE B type

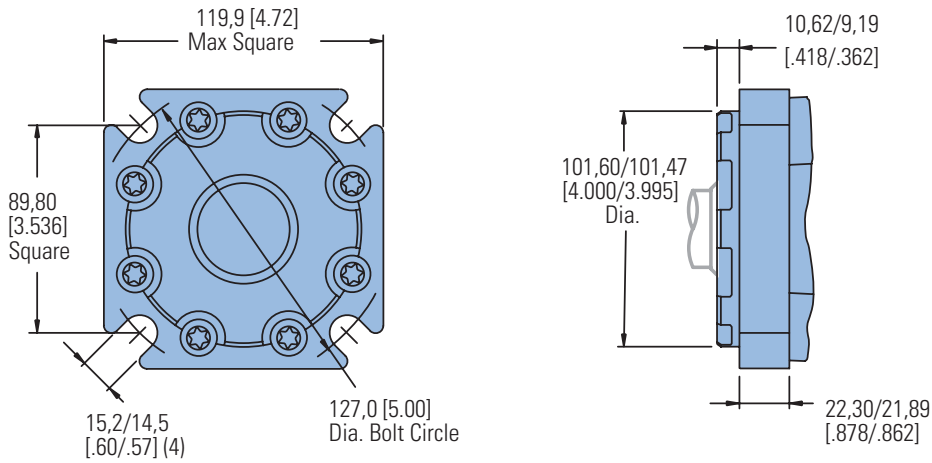

### Four Bolt (Wheel Motor)

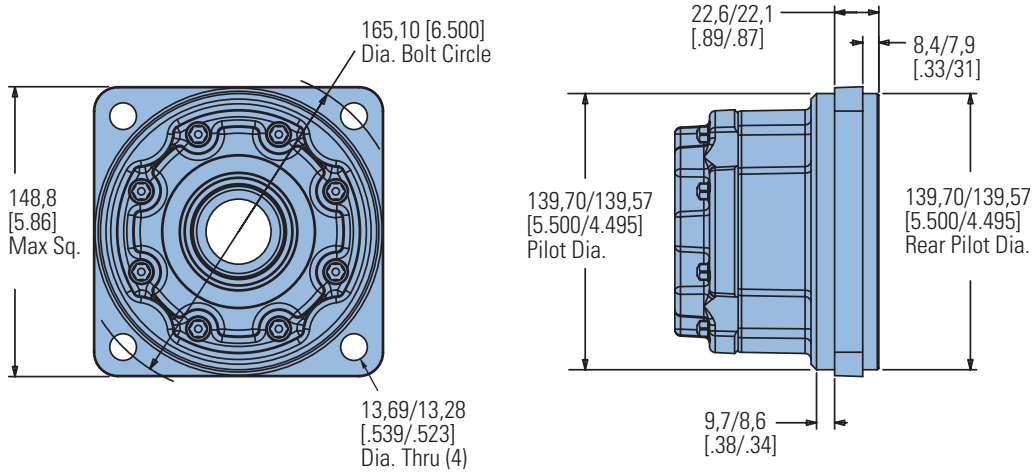

### Four Bolt (Wheel Motor- Short)

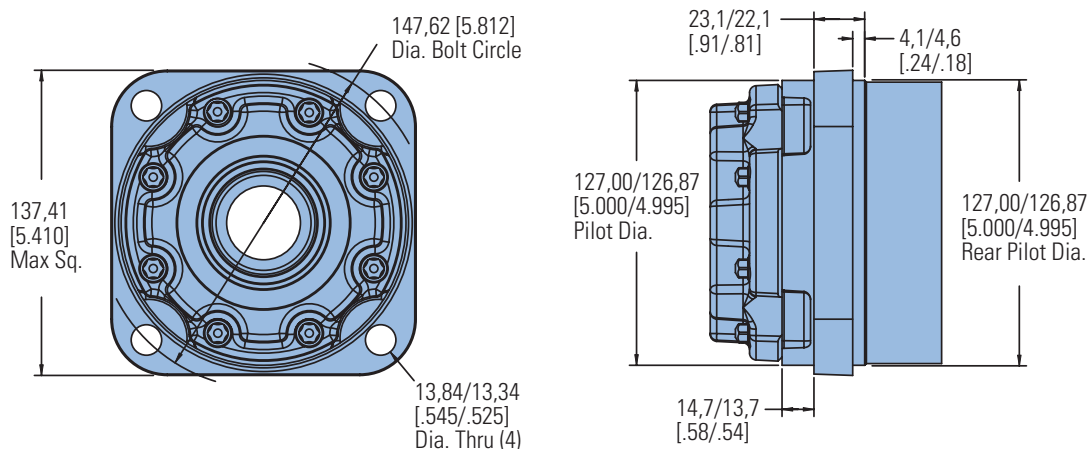

# 4000 Compact Series

## Dimensions

### Shafts

#### 1-5/8 Inch Tapered

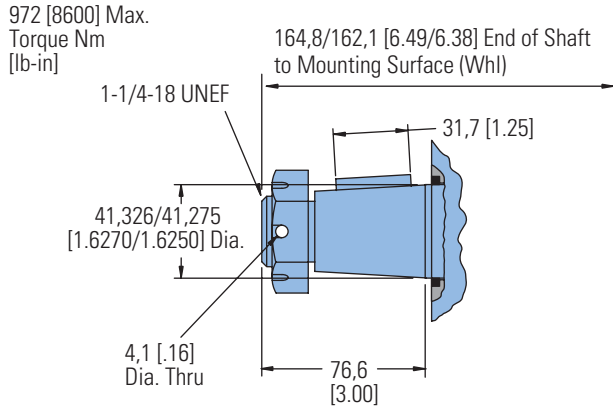

SAE J501 Standard Tapered Shaft  
125,00 0,17 Taper per Meter  
[1.500±.002 Taper per Foot]

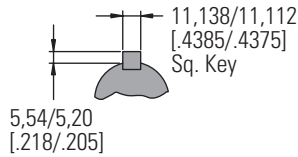

#### 1-1/4 Inch Tapered

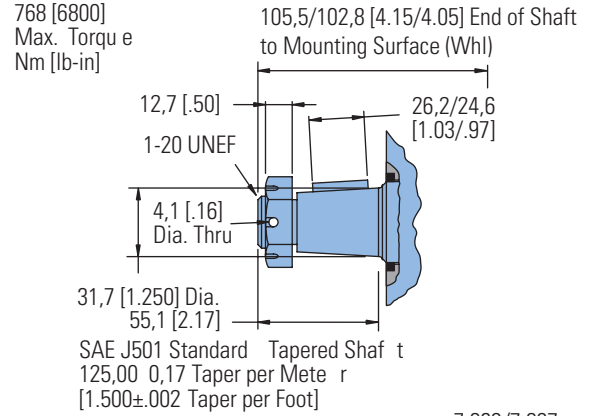

SAE J501 Standard Tapered Shaft  
125,00 0,17 Taper per Meter  
[1.500±.002 Taper per Foot]

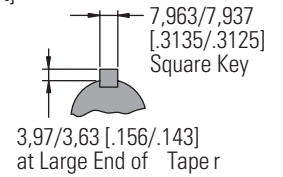

#### Tapered Shaft Hub Data

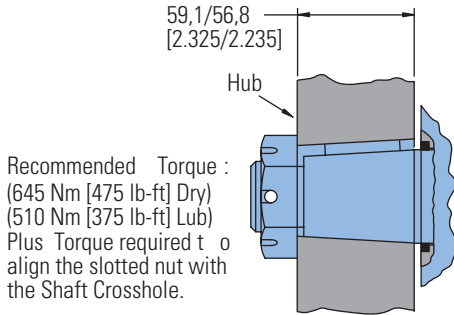

#### Tapered Shaft Hub Data

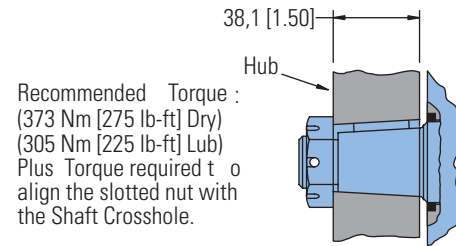

#### Slotted Hexagon Nut

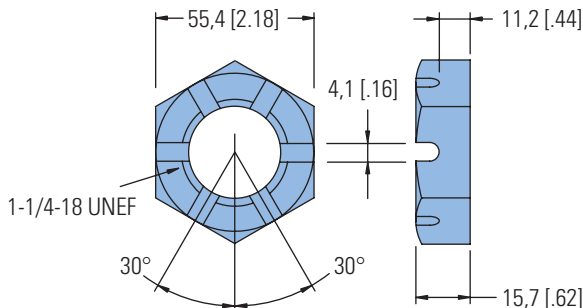

#### Slotted Hexagon Nut

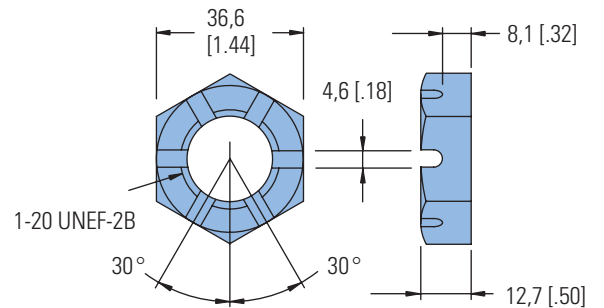

# 4000 Compact Series

## Dimensions

### Shafts

#### 1-1/2 Inch Straight

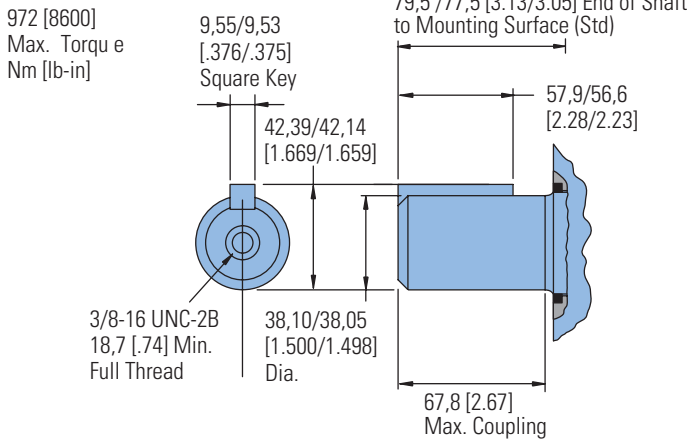

#### 1-1/4 Inch Straight

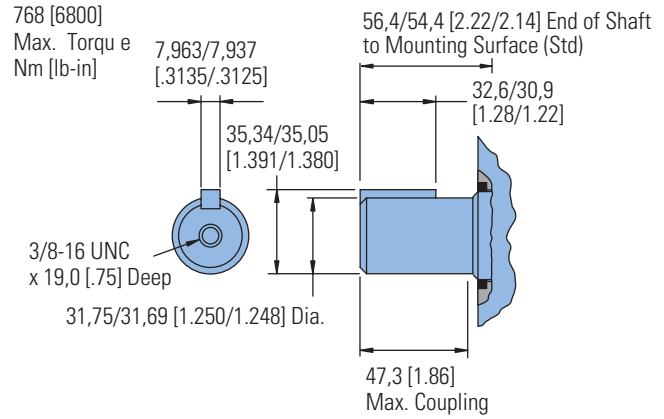

#### 40 mm Straight

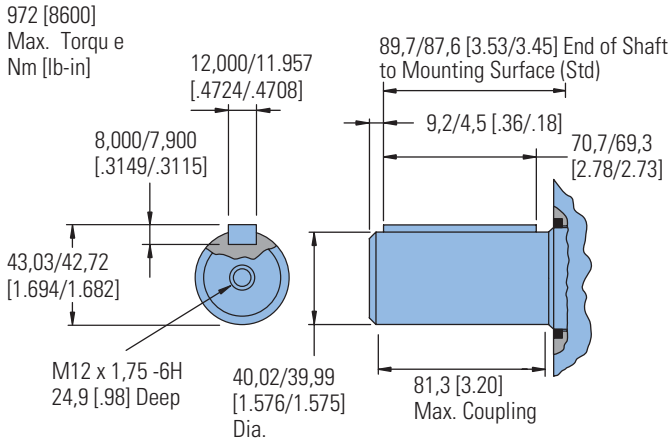

#### 32 mm Straight

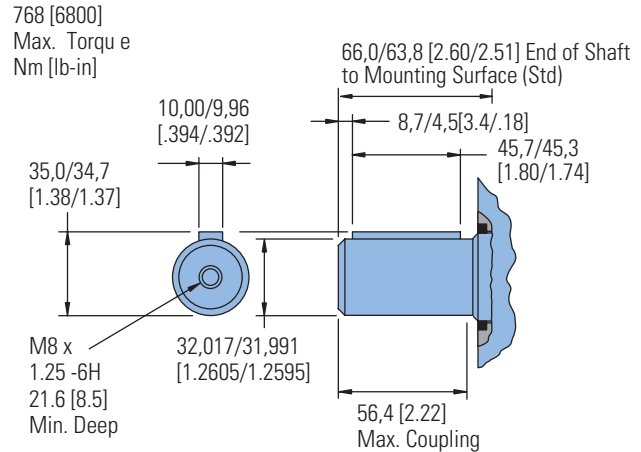

#### 1-1/2 Inch 17 Tooth Straight

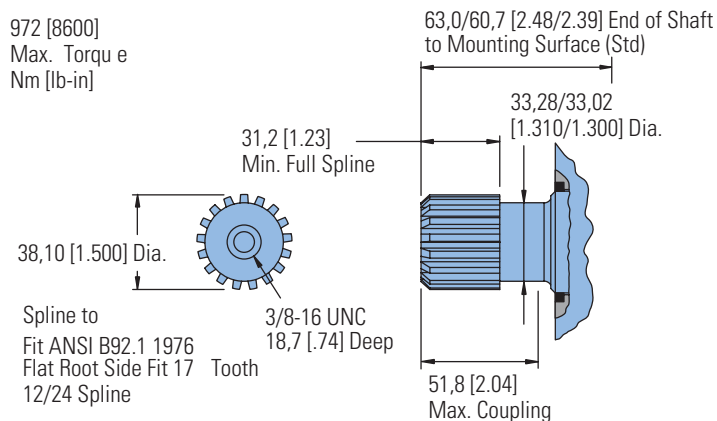

#### 1-1/4 Inch 14 Tooth Splined

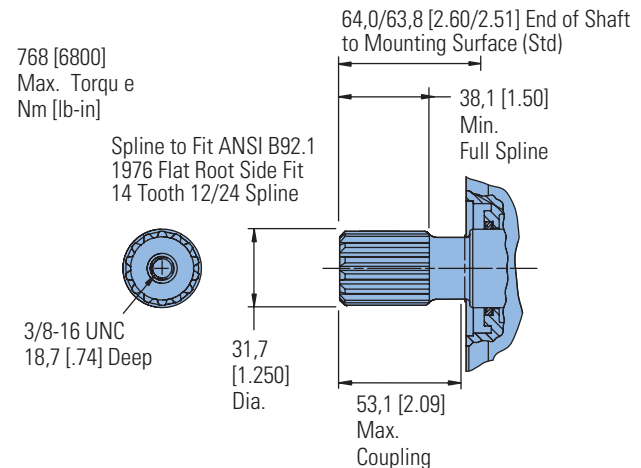

# 4000 Compact Series

## Shaft Side Load Capacity

These curves indicate the radial load capacity on the motor shafts) at various locations with an allowable external thrust load of 454 kg [1000 lb].

**Note:**

Case pressure will increase the allowable inward thrust load and decrease the allowable outward thrust load. Case pressure will push outward on the shaft at 94 kg/7 Bar [208 lb/100 PSI].

**Each curve is based on B 10 bearing life (2000**

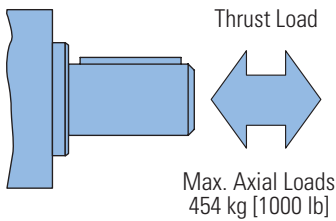

**hours of 12,000,000 shaft revolutions at 100 RPM) at rated output torque.**

To determine radial load at speeds other than 100 RPM, multiply the load values given on the bearing curve by the factors in the chart below.

RPM	Multiplication Factor
50	1.23
100	1.00
200	0.81
300	0.72
400	0.66
500	0.62
600	0.58
700	0.56
800	0.54

For 3,000,000 shaft revolutions or 500 hours — Increase these shaft loads 52%.

Standard Mount- All shaft options 1-1/4 inch and larger

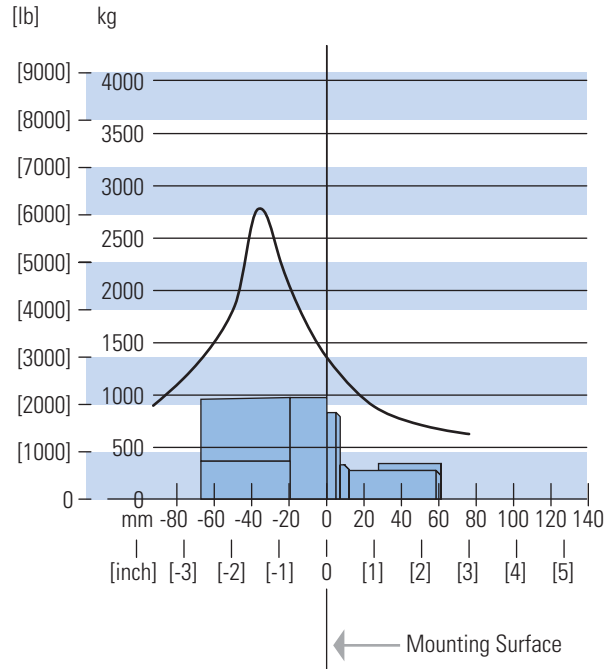

Wheel Mount- All shaft options 1-1/4 inch and larger

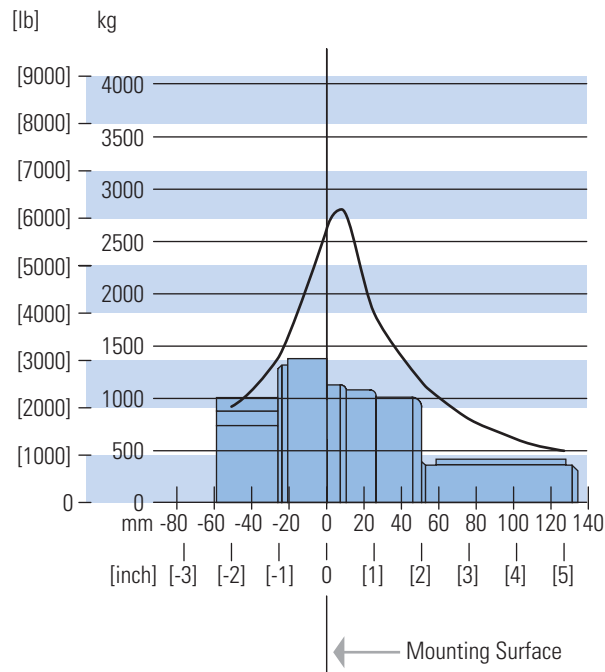

# 4000 Compact Series

## Case Pressure and Case Port

Char-Lynn 4000 Compact Series motors are durable and have long life as long as the recommended case pressure is not exceeded. Allowable case pressure is highest at low shaft speeds. Consequently, motor life will be shortened if case pressure exceeds these ratings (acceptability may vary with application). Determine if an external case drain is required from the case pressure seal limitation charts.

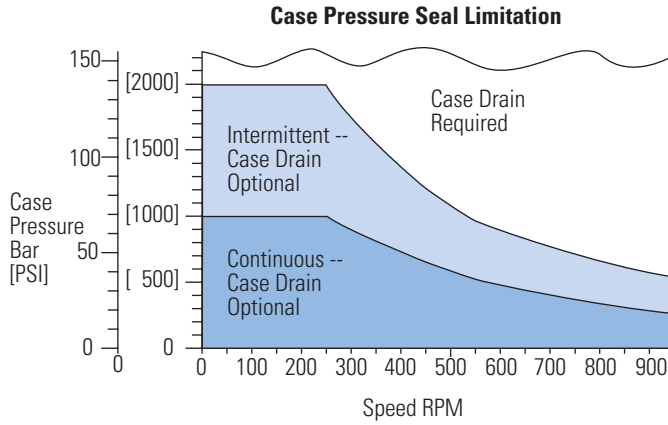

All Shaft options 1-1/4 inch and smaller.

### Case Porting Advantage

**Contamination Control** — flushing the motor case.

**Cooler Motor** — exiting oil draws motor heat away.

**Extend Motor Seal Life** — maintain low case pressure with a preset restriction in the case drain line.

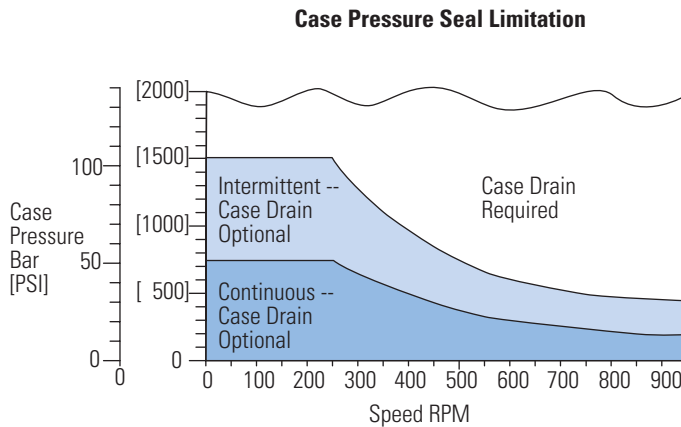

All Shaft options larger than 1-1/4 inch.

# 4000 Compact Series

## Dimensions

### Ports

#### 7/8-14 O-ring Ports (2) or G 1/2 (BSP) Ports (2)

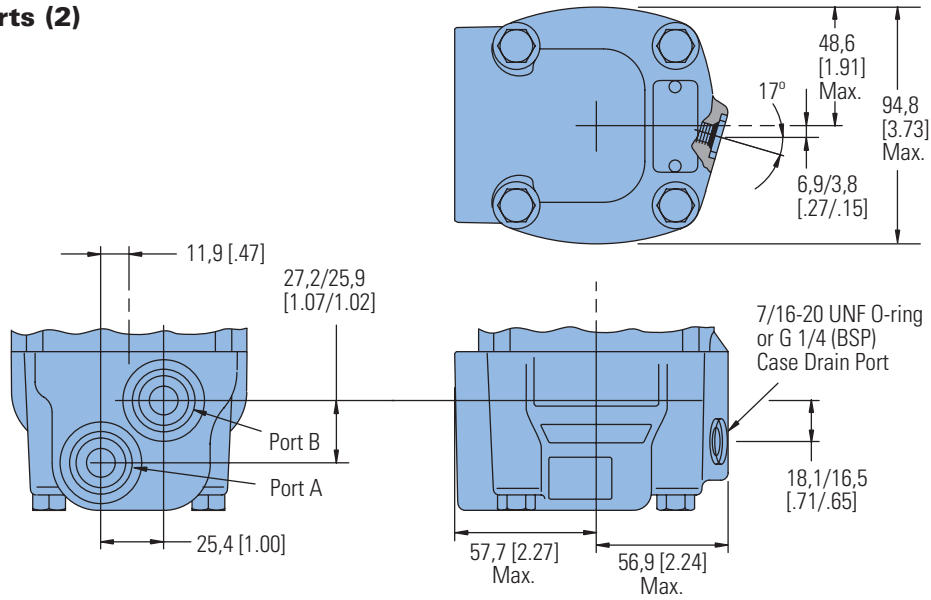

C-2

#### Manifold Mount

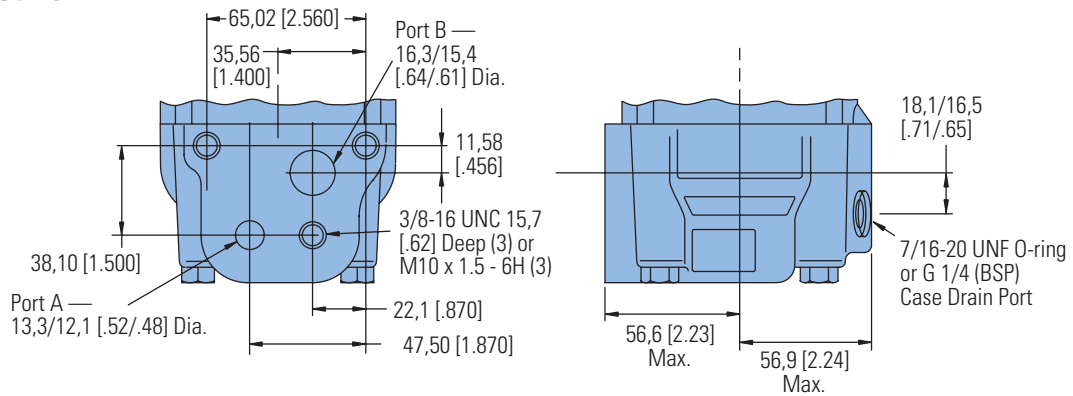



# 4000 Compact Series

## Dimensions

### Ports

#### 1-1/16-12 O-ring Ports (2) Positioned 180 Apart

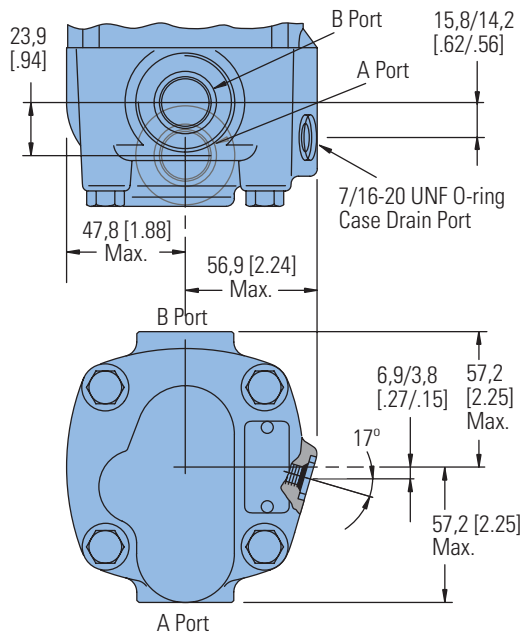

#### 7/8-14 O-ring End Ports (2)

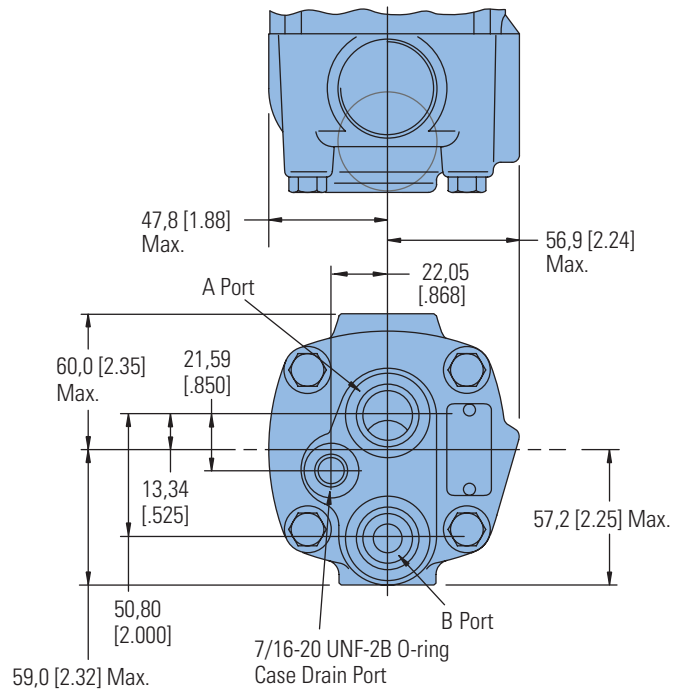

# 4000 Compact Series

## Dimensions

### Ports with Shuttle

#### 7/8-14 O-ring Ports (2) or G 1/2 (BSP) Ports (2)

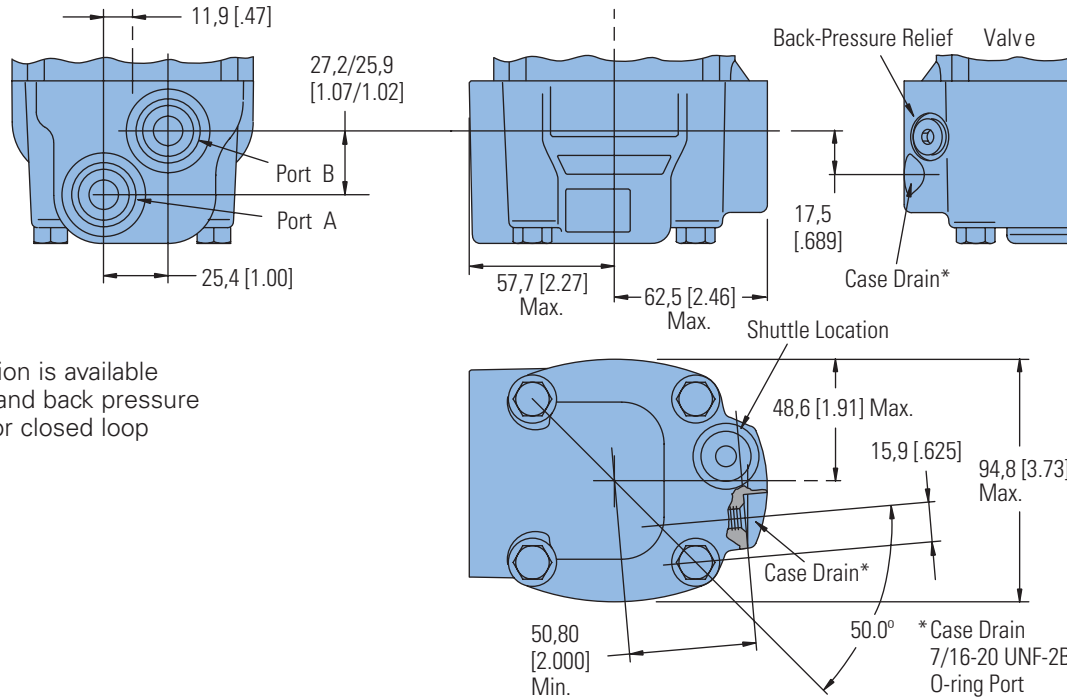

This port option is available with shuttle and back pressure relief valve for closed loop applications.

C-2

#### 7/8-14 O-ring End Ports (2)

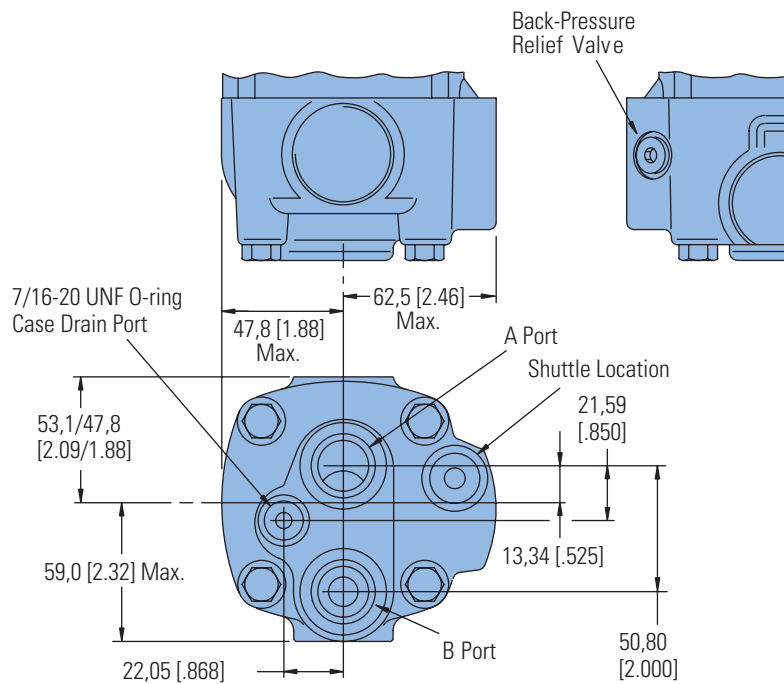

This port option is available with shuttle and back pressure relief valve for closed loop applications.

# 4000 Compact Series

The following 24-digit coding system has been developed to identify all of the configuration options for the 4000 Compact Series motor. Use this model code to specify a motor with the desired features. All 24 digits of the code must be present when ordering. You may want to photocopy the matrix below to ensure that each number is entered in the correct box.

## Model Code

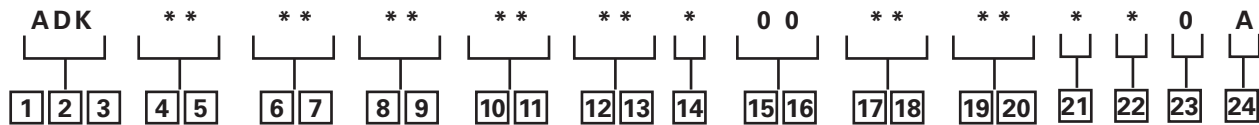

**1, 2, 3** Product Series  
ADK – 4000 Compact Series Motor

**4, 5** Displacement  
cm<sup>3</sup>/r [in<sup>3</sup>/r]

10 – 160 [ 9.8]  
12 – 200 [12.3]  
15 – 250 [15.4]  
20 – 325 [19.8]  
25 – 405 [24.6]  
30 – 490 [29.8]

**6, 7** Mounting Type

**AB – 4 Bolt (Wheel) 108,0 [4.25] Pilot Dia. and 13,59 [.535] Dia. Mounting Holes on 147,6 [5.81] Dia. B.C. 127,0 [5.00] Dia. Rear Mount Pilot**

AC – 2 Bolt SAE A (Std.) 82,5 [3.25] Pilot Dia and 13,59 [.535] Dia. Mtg. Holes on 106,4 [4.19] Dia. B.C.

AE – 4 Bolt (Bearingless) 101,6 [4.00] Pilot Dia. and 13,59 [.535] Dia. Mounting Holes on 127,0 [5.00] Dia. B.C.

**AF – 2 Bolt SAE B (Std.) 101,6 [4.00] Pilot Dia. and 14,35 [.565] Dia. Mtg. Holes on 146,0 [5.75] Dia. B.C.**

AH – 4 Bolt (Standard) 82,5 [3.25] Pilot Dia. and 14,59 [.535] Dia. Mounting Holes on 106,4 [4.19] Dia. B.C.

AJ – 4 Bolt Magneto (Std.) 82,6 [3.25] Pilot Dia. and 13,59 [.535] Dia. Mtg. Holes on 106,4 [4.19] Dia. B.C. 2,79 [1.10] Pilot Length

AP – 4 Bolt (wheel compatible for Hayes Brake) 107,9 [4.25] Pilot Dia. and 13,59 [.535] Dia. Mounting Holes on 147,6 [5.81] Dia. B.C. with Turned Down Housing to 88,9 [3.50] Dia.

**AG – 4 Bolt (Wheel - Short) 91,9 [3.62] Pilot Dia. 14,35 [.565] Dia. Holes on 147,6 [5.81] Dia. Bolt Circle with O-ring Groove**

**AT – 2 Bolt (Standard) 101,6 [4.00] Pilot Dia. 13,59 [.535] Dia. Holes on 146,0 [5.75] Dia. Bolt Circle (Similar to SAE B)**

BB\* – 4 Bolt (SAE B) (Standard) 101,6 [4.00] Pilot Dia. and 14,7 [.58] Dia. Mounting Slots on 127,0 [5.00] Dia. Bolt Circle

BE\* – 4 Bolt (Wheel) 139,7 [5.50] Front and Rear Pilot Dia. and 13,49 [.531] Dia. Mounting Holes on 165,1 [6.50] Dia. Bolt Circle

BG\* – 4 Bolt (Wheel-Short) 127,0 [5.00] Front and Rear Pilot Dia. and 13,59 [.535] Dia. Mounting Holes on 147,62 [5.812] Dia. Bolt Circle

**8, 9** Output Shaft

00 – None (Bearingless)  
02 – 1 1/4 inch Dia. Straight with 3/8 -16 Thread in end, 7,938 [.3125] Sq. x 31,75 [1.250] Straight Key

**03 – 1 1/4 inch Dia. .125 : 1 Tapered Shaft Per SAE J501 with 1-20 UNEF -2A Threaded Shaft end, and slotted Hex Nut, 7,938 [.3125] Sq. x 25,40 [1.000] Straight Key**

**04 – 31,75 [1.250] Dia. Flat Root Side Fit, 14 tooth, 12/24 DP 30° Involute Spline with .375-16 UNC-2B Thread in End, 33,0 [1.30] Minimum Full Spline Length**

**06 – 1 1/4 inch Dia. Splined 14T with 38,1 [1.50] Min. Full Spline Length and 53,1 [2.09] Max. Coupling Length**

08 – 40 mm Dia. Straight (with Straight Key) M12 x 1,75 - 6H Thread in end

10 – 32 mm dia. Straight (with Straight Key) M8 x 1,25 -6H Thread in end, and 56,4 [2.22] Max. Coupling Length

11 – 1 1/2 inch Dia. Straight (with Straight Key) 3/8 -16 Thread in end

**17 – 28,22 [1.111] Dia. Flat Root Side Fit, 17 Tooth, 16/32 DP 30° Involute Spline, 28.58 [1.125] Minimum Full Spline Length**

**98 – 1 5/8 inch Dia. Tapered with Straight Key and 1 1/4 -18 UNEF Slotted Hex. Nut**  
99 – 1 1/2 inch Dia. Splined 17T with 31,2 [1.23] Min. Full Spline Length

**10, 11** Ports

**AA – 7/8 -14 UNF -2B SAE O-ring (Staggered)**

**AB – 12,70 [.500] and 15,88 [.625] Dia. Ports (Manifold) and 3x 3/8 -16 UNC Port Block Mounting Holes**

**AD – 7/8 -14 UNF -2B SAE O-ring (End Ports)**

AE – 12,70 [.500] and 15,88 [.625] Dia. Ports (Manifold) and 3 x M10 x 1,5-6H Port Block Mounting Holes

AG – G 1/2 BSP Straight Thread ports (Staggered)

AH – 1 1/16 - 12 UN-2B O-Ring ports (Positioned 180° Apart)

**AJ – .750-16 UNF-2B SAE O-ring Ports – Ports Oriented 180° to each other**  
**BA – .875-14 UNF-2B SAE O-ring Ports – Port B Recessed 11,4 [.45] from Port A – End Ports – Cast Boss Removed**

**12, 13** Case Flow Options

00 – None

**01 – 7/16 -20 UNF -2B SAE O-ring Port (Case Drain)**

02 – G 1/4 (BSP) Straight Thread Port (Case Drain)

\* These mounting options are available with shaft options 08, 11, 98 and 99.

14 – Reverse Flow Shuttle Valve with G 1/4 (BSP) Straight Thread Port (Case Drain)

**14** Back-Pressure Relief Valve

0 – None

**A – Set at 4,5 bar [65 PSI] (for Manual Pumps)**

**15, 16** Valve Options

00 – None

**17, 18** Accessories

00 – None

**AA – Seal Guard**

AF – M12 Threaded Connector Digital Speed Sensor (Two 30 Pulse per rev. signals in quadrature)

AG – M12 Threaded Connector Digital Speed Sensor (One 60 Pulse per rev. speed signal and one directional signal)

**19, 20** Special Features (Hardware)

00 – None

01 – Viton Seals

**21** Special Features (Assembly)

0 – None

**A – Flange Rotated 90°**

B – Reverse Rotation

**22** Paint/ Special Packaging

0 – No Paint, Individual Box  
**A – Low Gloss Black Primer, Individual Box**

**23** Eaton Assigned Code when Applicable

0 – None

**24** Eaton Assigned Design Code

**A – First Code**

Feature in **bold** are preferred and allow for shorter lead time.

# Delta Series

## Highlights



### Description

This wheel motor is the latest addition to the Char Lynn product line. The Delta motor provides torques up to 11,500 in-lbs. Eaton has packed this motor with many “best in class” features: the optimized geroler profile ensures smooth operation; the disc valve technology has the best performance and the bearing capacity is the highest in the industry for very demanding applications.

### Delta Series

Geroler Element	12 Displacements
Flow l/min [GPM]	75 [20] Continuous**
	115 [30] Intermittent*
Speed RPM	670 Cont.**
	837 Inter.*
Pressure bar [PSI]	200 [3000] Cont.**
	275 [4000] Inter.*
Torque Nm [lb-in]	1015 [9000] Cont**.
	1185 [10500] Inter.*

\*\* Continuous— (Cont.) Continuous rating, motor may be run continuously at these ratings.

\* Intermittent— (Inter.) Intermittent operation, 10% of every minute.

### Features:

- Excellent reliability with time proven Char-Lynn components
- Proven disc valve technology with the highest efficiencies in its class
- Leak resistant motor with the front bearing protecting the shaft seal
- Torque up to 10,500 lb-in intermittent duty / Flow up to 30 GPM intermittent
- 12 displacements available from 6.9 to 46 CID
- Shaft sizes up to 1-5/8 inch
- 3-1/4 inch front pilot and 5 inch rear pilot
- STC ports available

### Benefits:

- Perfect replacement for Parker® TF-TG and White™ RE motors
- Lowest no load pressure drop which leads to longer life and lower temperature operation
- Highest overall efficiency: more available HP to the system than competitive motors
- The highest side load capacity with 4,500 lbs at 3” from the mount face

### Applications:

- Scissor Lift
- Boom Lift
- Industrial Sweeper
- Mower

Parker is a registered trademark of Parker Intangibles LLC.

White is a trademark of White Drive Products, Inc.



Boom Lift



Sweeper



Mower

# Delta Series

## Specifications

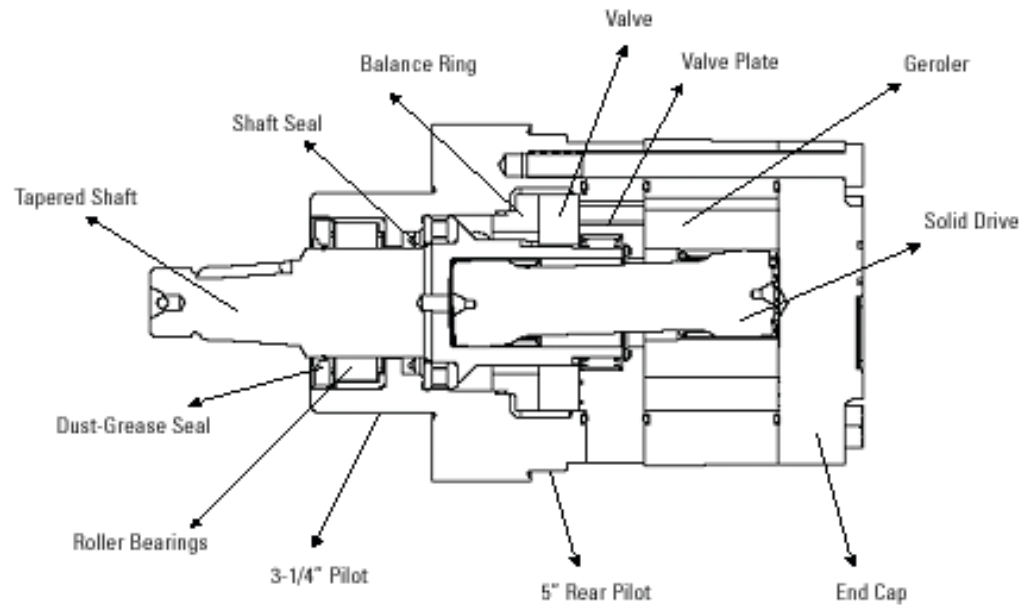

### DELTA SERIES MOTORS

Displ. cm <sup>3</sup> /r (in <sup>3</sup> /rev)		113 [6.9]	146 [8.9]	198 [12.1]	234 [14.3]	252 [15.4]	300 [18.3]	347 [21.2]	395 [24.1]	470 [28.7]	542 [33.1]	649 [39.6]	754 [46.0]
Max Speed (RPM)	Continuous	668	519	382	323	300	252	218	192	161	140	117	100
	Intermittent	831	778	516	485	450	379	327	288	241	209	175	151
@Flow													
Flow l/min [GPM]	Continuous	75 [20]	75 [20]	75 [20]	75 [20]	75 [20]	75 [20]	75 [20]	75 [20]	75 [20]	75 [20]	75 [20]	75 [20]
	Intermittent	95 [25]	115 [30]	115 [30]	115 [30]	115 [30]	115 [30]	115 [30]	115 [30]	115 [30]	115 [30]	115 [30]	115 [30]
Torque [10698]	Continuous	320 [2834]	429 [3800]	554 [4904]		651 [5763]		712 [6311]	844 [7472]	933 [8260]	972 [8607]	1039 [9199]	994 [8809]
	Intermittent	985 [8721]	1222 [10824]	1202 [10644]		1253 [11100]		1232 [10910]	563 [4984]	725 [6421]	852 [7543]	930 [8236]	1087 [9629]
Pressure [10698]	Continuous	205 [3000]	205 [3000]	205 [3000]		205 [3000]		205 [3000]	205 [3000]	205 [3000]	205 [3000]	190 [2750]	170 [2500]
	Intermittent	105 [1500]	170 [2500]	155 [2250]	140 [2000]	275 [4000]	275 [4000]	275 [4000]	275 [4000]	275 [4000]	275 [4000]	275 [4000]	275 [4000]
Weight		12,7 [28.0]	12,9 [28.5]	13,8 [30.5]	14,3 [31.5]	15,0 [33.0]		15,0 [33.0]	15,4 [34.0]	16,1 [35.5]	16,8 [37.0]	17,5 [38.5]	18,4 [40.5]
	kg [lb]												

#### Note:

Top assure best motor life, run motor for approximately one hour at 30% of rated pressure before application to full load. Be sure motor is filled with fluid prior to any load applications.

When pressurizing B port, all displacements have a continuous rating of 2000 psi.

#### Maximum Inlet Pressure:

310 bars (4500 PSI)

Do not exceed  $\Delta$  pressure rating (see chart above).

#### Recommended Fluids:

Premium quality, anti wear type hydraulic oil with a viscosity of no less than 70 SUS at operating temperature.

#### Recommended System Operating Temp.:

-34°C to 82°C [-30°F to 180°F]

#### Recommended Filtration:

Per ISO cleanliness Code 4406: 20/18/13

# Delta Series

## Performance Data

Motors run with high efficiency in all areas designated with a number for torque and speed. For best motor life select a motor to run with a torque and speed range shown in the light shaded area.

Performance data is typical at 120 SUS. Actual data may vary slightly from unit to unit in production.

	Continuous
	Intermittent
	No operation

		113cm <sup>3</sup> /r [6.9 in <sup>3</sup> /r]															
		Δ Pressure Bar [PSI]															
		17	34	52	69	86	103	121	138	155	172	190	207	224	241	259	276
		250	500	750	1000	1250	1500	1750	2000	2250	2500	2750	3000	3250	3500	3750	4000
2		204	450	686	915	1140	1355	1593	1814	2018	2197	2349	2573	2776	2975	3182	3362
	7.6	23	51	77	103	129	153	180	205	228	248	265	290	313	336	359	380
		65	64	63	62	60	60	59	57	56	55	56	54	52	48	49	44
4		210	457	706	950	1194	1436	1677	1906	2129	2351	2571	2790	3010	3231	3454	3660
	15	24	52	80	107	135	162	189	215	240	265	290	315	340	365	390	413
		132	131	130	129	128	127	126	125	123	122	120	118	115	113	112	110
6		196	445	696	942	1186	1432	1674	1914	2144	2367	2587	2805	3027	3252	3476	3695
	23	22	50	79	106	134	162	189	216	242	267	292	317	342	367	392	417
		199	196	196	195	193	192	191	190	189	185	183	182	180	177	174	172
8		176	425	677	921	1168	1420	1666	1906	2152	2386	2616	2834	3051	3265	3481	3697
	30	20	48	76	104	132	160	188	215	243	269	295	320	344	369	393	417
		266	264	263	261	261	259	257	257	255	252	250	248	246	244	241	237
10		160	407	659	901	1149	1398	1650	1894	2134	2370	2601	2823	3044	3258	3475	3654
	38	18	46	74	102	130	158	186	214	241	268	294	319	344	368	390	413
		333	333	329	326	324	323	321	320	318	314	312	309	306	303	301	295
12		134	382	632	876	1122	1372	1621	1868	2111	2353	2589	2821	3046	3270	3479	3680
	45	15	43	71	99	127	155	183	211	238	266	292	319	344	369	393	415
		399	398	396	393	392	389	387	386	383	381	377	374	372	370	367	364
14		111	357	608	855	1102	1350	1599	1847	2090	2330	2569	2800	3024	3250	3455	3614
	53	13	40	69	97	124	152	181	208	236	263	290	316	341	367	390	408
		466	465	462	460	457	455	453	451	449	446	442	438	436	433	429	415
16		81	325	577	822	1071	1321	1572	1817	2063	2307	2549	2781	3011	3237	3436	3578
	61	9	37	65	93	121	149	177	205	233	260	288	314	340	365	388	404
		533	532	529	527	524	522	520	517	516	513	509	506	503	500	496	477
18		48	295	543	790	1036	1283	1535	1781	2027	2271	2512	2751	2984	3214	3431	3597
	68	5	33	61	89	117	145	173	201	229	256	284	311	337	363	387	406
		601	600	597	593	591	586	586	583	581	577	573	570	568	564	559	542
20		14	263	510	758	1005	1249	1499	1746	1988	2231	2474	2712	2945	3176	3395	3597
	76	2	30	58	86	113	141	169	197	224	252	279	306	332	359	383	406
		668	666	664	661	658	654	652	649	646	644	640	637	634	630	628	621
22			228	477	725	972	1218	1468	1712	1957	2201	2447	2686	2917	3149	3350	3523
	83		26	54	82	110	138	166	193	221	249	276	303	329	355	378	398
			733	731	728	724	721	718	715	713	710	705	704	700	697	688	664
25			170	416	663	913	1153	1402	1646	1891	2136	2382	2622	2856	3081	3273	3452
	95		19	47	75	103	130	158	186	214	241	269	296	322	348	369	390
			831	829	827	825	821	818	815	812	809	805	803	800	794	776	745
30			114	429	755	1076	1400	1725	2047	2368	2687	3003	3323	3635	3942	4249	4552
	114		13	48	85	122	158	195	231	267	303	339	375	410	445	480	514
			778	777	773	770	765	759	756	753	749	746	744	742	740	737	735



		146cm <sup>3</sup> /r [8.9 in <sup>3</sup> /r]															
		Δ Pressure Bar [PSI]															
		17	34	52	69	86	103	121	138	155	172	190	207	224	241	259	276
		250	500	750	1000	1250	1500	1750	2000	2250	2500	2750	3000	3250	3500	3750	4000
2		288	596	907	1184	1445	1718	1992	2247	2537	2810	3039	3290	3595	3846	3996	4265
	7.6	32	67	102	134	163	194	225	254	286	317	343	371	406	434	451	482
		50	48	46	42	44	43	40	39	38	37	36	34	32	31	25	28
4		289	619	947	1267	1593	1914	2227	2482	2755	3042	3295	3615	3916	4135	4456	4680
	15	33	70	107	143	180	216	251	280	311	343	372	408	442	467	503	528
		102	100	98	96	95	95	94	93	91	88	84	81	79	76	74	70
6		275	604	934	1259	1588	1908	2232	2552	2869	3181	3497	3800	4102	4397	4680	4955
	23	31	68	105	142	179	215	252	288	324	359	395	429	463	496	528	559
		154	151	149	148	146	145	144	143	141	137	135	133	130	128	125	123
8		256	580	909	1235	1566	1887	2209	2528	2845	3160	3475	3783	4091	4397	4692	4984
	30	29	66	103	139	177	213	249	285	321	357	392	427	462	496	530	563
		206	204	201	200	198	198	196	195	190	187	185	182	179	179	176	173
10		227	553	879	1204	1535	1861	2184	2504	2820	3133	3447	3757	4061	4369	4667	4963
	38	26	62	99	136	173	210	247	283	318	354	389	424	459	493	527	560
		258	256	253	251	250	249	248	246	241	238	236	233	231	229	228	225
12		199	521	850	1172	1501	1825	2148	2469	2780	3091	3402	3714	4017	4324	4627	4922
	45	23	59	96	132	170	206	243	279	314	349	384	419	454	488	522	556
		310	308	305	303	301	300	299	297	292	290	287	284	282	281	278	276
14		157	480	809	1130	1458	1784	2104	2426	2743	3057	3369	3679	3983	4291	4593	4892
	53	18	54	91	128	165	201	238	274	310	345	380	415	450	484	519	552
		362	360	356	354	353	352	351	346	344	341	339	337	335	332	331	329
16		132	457	780	1102	1429	1753	2081	2397	2714	3025	3335	3645	3947	4255	4558	4857
	61	15	52	88	124	161	198	235	271	306	342	377	412	446	480	515	548
		414	412	408	406	405	403	402	398	395	392	389	387	384	382	380	377
18		98	414	742	1065	1390	1715	2039	2360	2675	2986	3295	3605	3906	4213	4518	4817
	68	11	47	84	120	157	194	230	266	302	337	372	407	441	476	510	544
		467	465	461	459	457	456	453	450	447	444	442	439	437	435	432	430
20		42	373	700	1020	1347	1670	1989	2308	2628	2944	3255	3568	3866	4172	4475	4774
	76	5	42	79	115	152	189	225	261	297	332	368	403	436	471	505	539
		519	517	514	511	509	507	503	500	498	495	492	489	488	485	484	482
22		16	328	659	978	1306	1628	1950	2268	2586	2900	3211	3522	3823	4128	4429	4732
	83	2	37	74	110	147	184	220	256	292	327	362	398	432	466	500	534
		571	569	565	562	559	559	555	552	549	546	544	541	538	536	534	531
25			253	576	899	1221	1544	1864	2179	2500	2811	3120	3433	3736	4036	4337	4639
	95		29	65	102	138	174	210	246	282	317	352	388	422	456	490	524
			647	645	641	639	637	633	629	626	624	621	618	616	613	612	609
30			114	429	755	1076</											

# Delta Series

## Performance Data

198cm<sup>3</sup>/r [12.1 in<sup>3</sup>/r]  
ΔPressure Bar [PSI]

	17 250	34 500	52 750	69 1000	86 1250	103 1500	121 1750	138 2000	155 2250	172 2500	190 2750	207 3000	224 3250	241 3500	259 3750	276 4000
2	313	732	1113	1480	1870	2249	2668	3059	3447	3822	4189	4544	4875	5194	5508	5948
7.6	35 36	83 35	126 34	167 32	211 31	254 30	301 29	345 27	389 27	432 26	473 24	513 22	550 21	586 18	622 17	671 18
4	367	809	1228	1640	2038	2437	2844	3234	3623	4010	4398	4779	5164	5545	5917	6275
15	41 75	91 74	139 72	185 71	230 69	275 68	321 67	365 65	409 63	453 62	497 61	540 58	583 56	626 56	668 54	708 52
6	365	799	1231	1654	2066	2473	2878	3270	3665	4056	4446	4833	5215	5598	5975	6347
23	41 112	90 111	139 110	187 109	233 107	279 106	325 104	369 102	414 101	458 99	502 98	546 96	589 95	632 93	675 91	717 89
8	343	782	1219	1648	2069	2484	2898	3300	3702	4093	4482	4865	5237	5607	5976	6349
30	39 151	88 150	138 149	186 147	234 146	280 145	327 143	373 142	418 140	462 138	506 135	549 134	591 133	633 131	675 129	717 127
10	322	759	1201	1633	2063	2483	2904	3316	3726	4125	4515	4904	5290	5672	6048	6421
38	36 190	86 188	136 187	184 186	233 185	280 182	328 181	374 178	421 177	466 174	510 173	554 171	597 169	640 168	683 166	725 164
12	283	719	1158	1590	2020	2448	2868	3279	3691	4096	4492	4883	5265	5644	6015	6385
45	32 229	81 227	131 226	180 224	228 223	276 221	324 220	370 218	417 216	462 215	507 212	551 211	594 209	637 206	679 205	721 202
14	238	671	1110	1538	1970	2396	2816	3228	3644	4050	4451	4846	5231	5613	5982	6357
53	27 267	76 266	125 264	174 262	222 261	271 259	318 257	364 255	411 253	457 251	503 249	547 246	591 244	634 242	675 240	718 238
16	191	625	1063	1493	1923	2345	2768	3182	3596	4003	4403	4801	5191	5576	5947	6316
61	22 305	71 304	120 303	169 301	217 300	265 298	312 296	359 295	406 293	452 291	497 289	542 287	586 285	630 284	671 281	713 279
18	139	567	1006	1438	1871	2299	2720	3133	3547	3956	4359	4760	5128	5492	5871	6247
68	16 342	64 341	114 340	162 339	211 337	260 335	307 333	354 331	400 330	447 328	492 326	537 324	579 322	620 321	663 319	705 317
20	99	457	886	1315	1745	2168	2590	3006	3418	3822	4224	4622	5018	5418	5816	6208
76	11 382	52 380	100 378	148 377	197 375	245 373	292 371	339 369	386 366	432 364	477 362	522 359	567 358	612 356	657 354	701 352
22	15	383	810	1243	1676	2096	2520	2938	3351	3759	4161	4558	4953	5339	5722	6095
83	2 420	43 417	91 416	140 415	189 413	237 411	284 409	332 407	378 405	424 403	470 401	515 399	559 397	603 395	646 392	688 390
25		272	700	1131	1559	1985	2408	2823	3231	3639	4042	4443	4842	5229	5617	5992
95		31 476	79 475	128 474	176 472	224 470	272 468	319 466	365 465	411 463	456 461	502 459	547 457	590 455	634 453	677 450
30		163	600	1037	1474	1902	2315	2723	3134	3536	3933	4338	4737	5125	5516	5899
114		18 516	68 506	117 494	166 487	215 484	261 488	307 494	354 501	399 506	444 511	490 514	535 515	579 516	623 515	666 514

163 } Torque lb-in  
18 } Nm  
516 } Speed RPM

234cm<sup>3</sup>/r [14.3 in<sup>3</sup>/r]  
ΔPressure Bar [PSI]

	17 250	34 500	52 750	69 1000	86 1250	103 1500	121 1750	138 2000	155 2250	172 2500	190 2750	207 3000	224 3250	241 3500	259 3750	276 4000
2	470	971	1457	1921	2414	2877	3348	3821	4275	4730	5164	5630	5997	6446	6863	7217
7.6	53 31	110 30	164 29	217 28	273 26	325 25	378 25	431 25	483 24	534 23	583 22	636 21	677 19	728 20	775 19	815 15
4	468	988	1504	1989	2482	2964	3447	3916	4384	4843	5302	5763	6213	6668	7113	7543
15	53 64	112 62	170 61	225 60	280 59	335 58	389 57	442 56	495 55	547 55	599 54	651 54	701 52	753 51	803 50	852 48
6	449	966	1484	1980	2470	2953	3445	3922	4397	4851	5304	5750	6197	6643	7085	7524
23	51 96	109 95	168 93	224 92	279 92	333 91	389 90	443 89	496 88	548 88	599 88	649 87	700 86	750 86	800 84	849 83
8	416	931	1446	1954	2458	2948	3438	3909	4381	4835	5280	5714	6150	6584	7015	7445
30	47 129	105 128	163 126	221 125	277 124	333 123	388 123	441 121	495 121	546 120	596 120	645 119	694 119	743 118	792 117	841 116
10	380	896	1410	1917	2425	2919	3412	3890	4373	4831	5280	5716	6148	6586	7017	7452
38	43 161	101 160	159 158	216 157	274 156	330 155	385 154	439 153	494 153	545 152	596 151	645 150	694 149	744 148	792 147	841 146
12	341	856	1366	1876	2384	2880	3370	3843	4319	4782	5229	5665	6102	6537	6962	7392
45	39 194	97 193	154 191	212 190	269 189	325 188	380 187	434 186	488 185	540 185	590 184	640 183	689 182	738 181	786 180	835 178
14	290	804	1312	1813	2320	2821	3315	3793	4268	4732	5181	5623	6057	6485	6907	7327
53	33 226	91 225	148 224	205 222	262 221	318 220	374 219	428 218	482 217	534 216	585 216	635 215	684 214	732 212	780 211	827 209
16	239	743	1249	1756	2264	2759	3255	3735	4207	4669	5122	5568	6004	6432	6845	7268
61	27 258	84 258	141 257	198 255	256 254	312 253	367 252	422 251	475 251	527 250	578 249	629 247	678 246	726 245	773 244	820 242
18	176	688	1187	1694	2203	2698	3195	3676	4146	4603	5055	5497	5930	6358	6774	7194
68	20 291	78 291	134 289	191 287	249 286	305 285	361 284	415 283	468 282	520 281	571 279	621 278	669 277	718 276	765 276	812 275
20	108	614	1121	1623	2124	2620	3118	3603	4077	4541	4990	5430	5865	6301	6720	7139
76	12 323	69 323	127 322	183 320	240 319	296 317	352 317	407 316	460 314	513 314	563 311	613 310	662 310	711 310	759 309	806 309
22	28	535	1081	1582	2082	2579	3071	3550	4018	4483	4943	5406	5855	6300	6723	7139
83	3 355	60 355	122 355	179 352	235 351	291 350	347 349	401 348	454 345	506 343	558 342	610 341	661 341	711 341	759 341	806 341
25		410	956	1460	1959	2454	2941	3419	3892	4356	4806	5251	5683	6117	6531	6939
95		46 404	108 404	165 402	221 401	277 399	332 398	386 397	439 394	492 392	543 391	593 390	642 390	691 389	737 390	783 389
30		171	700	1297	1735	2226	2718	3204	3689	4162	4623	5079	5519	5959	6377	6781
114		19 485	79 485	146 485	196 483	251 481	307 480	362 478	417 476	470 474	522 472	573 472	623 471	673 471	720 471	766 471

# Delta Series

## Performance Data

**252cm<sup>3</sup>/r [15.4 in<sup>3</sup>/r]**  
**ΔPressure Bar [PSI]**

	17	34	52	69	86	103	121	138	155	172	190	207	224	241	259	276
	250	500	750	1000	1250	1500	1750	2000	2250	2500	2750	3000	3250	3500	3750	4000
2	485	1011	1520	2032	2564	3059	3569	4065	4561	5085	5589	6054	6536	6891	7388	7872
7.6	55	114	172	229	289	345	403	459	515	574	631	683	738	778	834	889
4	504	1062	1609	2145	2684	3213	3744	4263	4780	5294	5804	6311	6811	7308	7787	8236
15	57	120	182	242	303	363	423	481	540	598	655	712	769	825	879	930
6	478	1031	1585	2132	2670	3195	3717	4222	4726	5222	5721	6211	6700	7179	7658	8118
23	54	116	179	241	301	361	420	477	534	590	646	701	756	810	865	917
8	453	1012	1571	2115	2664	3191	3717	4224	4725	5215	5706	6194	6678	7161	7628	8076
30	51	114	177	239	301	360	420	477	533	589	644	699	754	808	861	912
10	398	957	1516	2063	2609	3137	3668	4181	4678	5157	5636	6116	6589	7059	7522	7974
38	45	108	171	233	295	354	414	472	528	582	636	690	744	797	849	900
12	370	914	1468	2011	2557	3085	3614	4125	4622	5102	5577	6059	6538	7017	7497	7966
45	42	103	166	227	289	348	408	466	522	576	630	684	738	792	846	899
14	290	842	1399	1948	2496	3024	3552	4065	4571	5056	5525	5987	6445	6905	7359	7813
53	33	95	158	220	282	341	401	459	516	571	624	676	728	780	831	882
16	239	795	1346	1891	2434	2962	3494	4003	4511	4995	5461	5919	6382	6841	7292	7743
61	27	90	152	213	275	334	395	452	509	564	616	668	720	772	823	874
18	157	716	1265	1810	2355	2881	3408	3921	4431	4924	5401	5860	6310	6749	7184	7627
68	18	81	143	204	266	325	385	443	500	556	610	662	712	762	811	861
20	96	650	1203	1750	2294	2820	3345	3857	4366	4865	5340	5801	6242	6686	7122	7553
76	11	73	136	198	259	318	378	435	493	549	603	655	705	755	804	853
22	26	569	1111	1656	2195	2725	3250	3763	4268	4769	5259	5733	6182	6609	7030	7459
83	3	64	125	187	248	308	367	425	482	538	594	647	698	746	794	842
25	330	330	330	328	327	324	322	320	316	314	313	314	316	318	320	320
95		425	967	1508	2042	2574	3093	3605	4110	4602	5084	5561	6028	6482	6899	7316
30		48	109	170	231	291	349	407	464	520	574	628	681	732	779	826
114		375	375	374	372	369	366	364	361	358	357	356	358	361	364	364
		179	723	1266	1800	2330	2852	3364	3868	4368	4856	5338	5811	6269	6701	7096
		20	82	143	203	263	322	380	437	493	548	603	656	708	757	801
		450	450	450	449	447	443	439	436	433	430	430	431	434	437	438

179 } Torque lb-in  
 20 } Nm  
 450 } Speed RPM

**300cm<sup>3</sup>/r [18.3 in<sup>3</sup>/r]**  
**ΔPressure Bar [PSI]**

	17	34	52	69	86	103	121	138	155	172	190	207	224	241	259	276
	250	500	750	1000	1250	1500	1750	2000	2250	2500	2750	3000	3250	3500	3750	4000
2	608	1257	1919	2553	3196	3824	4475	5087	5707	6307	6901	7472	8015	8484	8962	9413
7.6	69	142	217	288	361	432	505	574	644	712	779	844	905	958	1012	1063
4	612	1283	1940	2587	3227	3856	4483	5094	5693	6293	6881	7462	8024	8574	9113	9629
15	69	145	219	292	364	435	506	575	643	710	777	842	906	968	1029	1087
6	570	1248	1906	2547	3178	3800	4420	5025	5619	6203	6773	7345	7899	8449	8992	9525
23	64	141	215	288	359	429	499	567	634	700	765	829	892	954	1015	1075
8	540	1210	1871	2522	3152	3781	4404	5008	5607	6186	6749	7319	7879	8433	8977	9512
30	61	137	211	285	356	427	497	565	633	698	762	826	890	952	1013	1074
10	496	1161	1825	2471	3110	3733	4362	4968	5574	6157	6721	7274	7811	8356	8887	9416
38	56	131	206	279	351	421	492	561	629	695	759	821	882	943	1003	1063
12	443	1108	1768	2418	3059	3688	4307	4918	5526	6114	6681	7239	7786	8338	8876	9411
45	50	125	200	273	345	416	486	555	624	690	754	817	879	941	1002	1062
14	387	1034	1701	2346	2985	3610	4227	4839	5452	6050	6622	7184	7723	8269	8816	9362
53	44	117	192	265	337	408	477	546	615	683	748	811	872	934	995	1057
16	366	961	1620	2264	2903	3530	4147	4753	5366	5960	6540	7098	7642	8169	8685	9211
61	41	109	183	256	328	399	468	537	606	673	738	801	863	922	980	1040
18	291	893	1546	2187	2829	3450	4067	4678	5283	5873	6451	7005	7537	8064	8580	9103
68	33	101	175	247	319	390	459	528	596	663	728	791	851	910	969	1028
20	204	797	1444	2094	2736	3361	3974	4585	5184	5775	6353	6907	7448	7974	8489	8992
76	23	90	163	236	309	380	449	518	585	652	717	780	841	900	958	1015
22	102	710	1366	2013	2651	3270	3885	4496	5096	5689	6271	6831	7362	7877	8375	8880
83	12	80	154	227	299	369	439	508	575	642	708	771	831	889	945	1003
25	278	278	278	277	274	272	269	267	265	264	263	265	269	273	275	275
95		553	1208	1851	2489	3114	3726	4335	4930	5523	6108	6670	7220	7783	8298	8777
30		62	136	209	281	352	421	489	557	624	690	753	815	879	937	991
114		316	316	316	313	310	307	303	301	299	298	298	301	306	310	312
		233	941	1539	2179	2811	3430	4028	4625	5217	5802	6385	6957	7522	8060	8565
		26	106	174	246	317	387	455	522	589	655	721	785	849	910	967
		379	379	379	377	374	371	367	365	363	362	361	364	368	374	376



# Delta Series

## Performance Data

**347cm<sup>3</sup>/r [21.2 in<sup>3</sup>/r]**  
**ΔPressure Bar [PSI]**

		17	34	52	69	86	103	121	138	155	172	190	207	224	241	259	276
		250	500	750	1000	1250	1500	1750	2000	2250	2500	2750	3000	3250	3500	3750	4000
Flow LPM [GPM]	2	687	1415	2128	2824	3532	4248	4947	5633	6298	6964	7575	8182	8743	9209	9624	10081
	7.6	78	160	240	319	399	480	558	636	711	786	855	924	987	1040	1087	1138
	4	689	1443	2179	2891	3606	4302	4986	5653	6316	6965	7615	8260	8891	9515	10120	10698
	15	78	163	246	326	407	486	563	638	713	786	860	933	1004	1074	1143	1208
	6	648	1406	2154	2866	3580	4276	4970	5641	6290	6921	7563	8190	8812	9427	10029	10630
	23	73	159	243	324	404	483	561	637	710	781	854	925	995	1064	1132	1200
	8	606	1356	2105	2825	3545	4241	4943	5621	6274	6899	7522	8144	8768	9388	9998	10598
	30	68	153	238	319	400	479	558	635	708	779	849	919	990	1060	1129	1196
	10	550	1295	2041	2765	3488	4188	4891	5585	6264	6899	7505	8091	8672	9238	9885	10488
	38	62	146	230	312	394	473	552	631	707	779	847	913	979	1048	1116	1184
	12	478	1227	1976	2698	3411	4108	4802	5479	6146	6782	7396	7992	8585	9176	9767	10345
	45	54	139	223	305	385	464	542	619	694	766	835	902	969	1036	1103	1168
	14	409	1151	1896	2624	3344	4048	4742	5418	6083	6722	7339	7939	8541	9142	9738	10318
	53	46	130	214	296	378	457	535	612	687	759	829	896	964	1032	1099	1165
	16	339	1033	1774	2494	3209	3907	4605	5280	5956	6610	7243	7850	8438	9014	9582	10166
	61	38	117	200	282	362	441	520	596	672	746	818	886	953	1018	1083	1148
18	245	943	1676	2401	3113	3809	4500	5175	5837	6477	7107	7711	8308	8895	9466	10040	
68	28	106	189	271	351	430	508	584	659	731	802	871	938	1004	1069	1133	
20	143	832	1571	2290	3003	3697	4386	5050	5715	6351	6968	7569	8147	8721	9297	9855	
76	16	94	177	259	339	417	495	570	645	717	787	855	920	985	1050	1113	
22	34	715	1454	2175	2896	3594	4280	4950	5602	6236	6854	7449	8027	8590	9150	9705	
83	4	81	164	246	327	406	483	559	632	704	774	841	906	970	1033	1096	
25	240	240	240	240	240	238	236	233	230	228	226	226	228	231	237	240	
95	59	141	222	304	383	461	537	611	684	755	824	890	955	1017	1076	1133	
30	272	272	272	272	272	272	269	266	263	261	259	259	261	265	270	272	
114	152	1072	1749	2434	3123	3802	4468	5114	5763	6400	7018	7633	8232	8819	9397	9966	
	17	121	197	275	353	429	504	577	651	723	792	862	929	996	1061	1126	
	327	327	327	327	327	327	323	319	315	314	313	315	319	323	327	327	

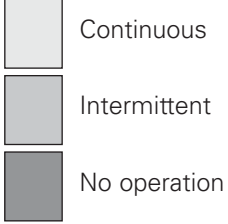

152 } Torque lb-in  
 17 } Nm  
 327 } Speed RPM

**395cm<sup>3</sup>/r [24.1 in<sup>3</sup>/r]**  
**ΔPressure Bar [PSI]**

		17	34	52	69	86	103	121	138	155	172	190	207	224	241
		250	500	750	1000	1250	1500	1750	2000	2250	2500	2750	3000	3250	3500
Flow LPM [GPM]	2	782	1622	2436	3237	4034	4837	5650	6428	7213	7911	8607	9235	9798	10439
	7.6	88	183	275	365	455	546	638	726	814	893	972	1043	1106	1179
	4	770	1643	2476	3287	4088	4860	5617	6357	7103	7838	8566	9285	9990	10684
	15	87	186	280	371	462	549	634	718	802	885	967	1048	1128	1206
	6	746	1609	2460	3280	4083	4867	5644	6384	7103	7811	8520	9232	9930	10616
	23	84	182	278	370	461	549	637	721	802	882	962	1042	1121	1199
	8	699	1561	2430	3249	4062	4852	5638	6398	7126	7820	8506	9198	9884	10565
	30	79	176	274	367	459	548	637	722	805	883	960	1038	1116	1193
	10	630	1489	2345	3180	4008	4819	5622	6397	7142	7856	8525	9142	9776	10438
	38	71	168	265	359	453	544	635	722	806	887	962	1032	1104	1178
	12	556	1412	2264	3090	3898	4689	5473	6225	6976	7710	8415	9081	9681	10304
	45	63	159	256	349	440	529	618	703	788	870	950	1025	1093	1163
	14	469	1325	2178	2999	3819	4611	5391	6137	6867	7581	8270	8942	9598	10234
	53	53	150	246	339	431	521	609	693	775	856	934	1010	1084	1155
	16	360	1220	2069	2894	3715	4506	5290	6048	6782	7495	8190	8873	9534	10181
	61	41	138	234	327	419	509	597	683	766	846	925	1002	1076	1149
18	334	1098	1951	2777	3591	4386	5172	5924	6665	7387	8087	8763	9418	10048	
68	38	124	220	314	405	495	584	669	752	834	913	989	1063	1134	
20	221	993	1837	2660	3479	4259	5030	5780	6518	7238	7939	8613	9258	9892	
76	25	112	207	300	393	481	568	653	736	817	896	972	1045	1117	
22	115	862	1698	2521	3337	4135	4895	5641	6366	7067	7752	8414	9062	9702	
83	13	97	192	285	377	467	553	637	719	798	875	950	1023	1095	
25	211	211	211	211	211	209	206	203	201	200	199	200	204	209	
95	637	1473	2296	3117	3909	4687	5434	6163	6861	7536	8192	8829	9475	10117	
30	72	166	259	352	441	529	613	696	775	851	925	997	1070	1143	
114	24	122	215	308	398	487	573	658	739	817	894	968	1042	1116	
	288	288	288	288	288	286	283	280	277	274	273	275	280	287	

# Delta Series

## Performance Data

Continuous  
 Intermittent  
 No operation

		<b>470cm<sup>3</sup>/r [28.7 in<sup>3</sup>/r]</b>											
		<b>ΔPressure Bar [PSI]</b>											
		17	34	52	69	86	103	121	138	155	172	190	207
		250	500	750	1000	1250	1500	1750	2000	2250	2500	2750	3000
2		925	1885	2820	3727	4639	5526	6404	7270	8129	8978	9794	10551
	7.6	104	213	318	421	524	624	723	821	918	1014	1106	1191
4		942	1942	2917	3849	4776	5692	6594	7488	8352	9199	10014	10824
	15	106	219	329	435	539	643	744	845	943	1039	1131	1222
6		906	1921	2892	3833	4772	5676	6572	7440	8309	9152	9974	10786
	23	102	217	327	433	539	641	742	840	938	1033	1126	1218
8		856	1866	2853	3795	4730	5634	6520	7379	8230	9075	9895	10693
	30	97	211	322	428	534	636	736	833	929	1025	1117	1207
10		780	1799	2800	3745	4685	5594	6479	7337	8177	9009	9843	10638
	38	88	203	316	423	529	632	731	828	923	1017	1111	1201
12		699	1709	2711	3661	4597	5508	6403	7258	8101	8916	9719	10506
	45	79	193	306	413	519	622	723	819	915	1007	1097	1186
14		596	1612	2609	3561	4490	5390	6268	7112	7941	8743	9519	10282
	53	67	182	295	402	507	608	708	803	897	987	1075	1161
16		467	1486	2480	3440	4371	5268	6152	6992	7810	8601	9370	10118
	61	53	168	280	388	493	595	695	789	882	971	1058	1142
18		332	1353	2357	3317	4256	5157	6043	6892	7713	8501	9270	10026
	68	37	153	266	375	481	582	682	778	871	960	1047	1132
20		304	1226	2218	3172	4102	4994	5873	6731	7557	8365	9147	9922
	76	34	138	250	358	463	564	663	760	853	944	1033	1120
22		137	1059	2048	3004	3945	4840	5727	6576	7399	8198	8967	9715
	83	15	120	231	339	445	546	647	742	835	926	1012	1097
25		833	1816	2765	3680	4575	5455	6313	7133	7928	8691	9436	10165
	95	94	205	312	415	517	616	713	805	895	981	1065	1149
30		491	1318	2295	3232	4142	5022	5881	6721	7522	8300	9057	9792
	114	55	149	259	365	468	567	664	759	849	937	1022	1105
30		491	1318	2295	3232	4142	5022	5881	6721	7522	8300	9057	9792
	114	241	241	241	241	241	240	237	236	236	233	232	227

491 } Torque lb-in  
 55 } Nm  
 241 } Speed RPM



		<b>542cm<sup>3</sup>/r [33.1 in<sup>3</sup>/r]</b>											
		<b>ΔPressure Bar [PSI]</b>											
		17	34	52	69	86	103	121	138	155	172	190	207
		250	500	750	1000	1250	1500	1750	2000	2250	2500	2750	3000
2		1131	2304	3433	4558	5668	6725	7732	8683	9645	10457	11181	11817
	7.6	128	260	388	515	640	759	873	980	1089	1181	1267	1347
4		1139	2352	3515	4638	5735	6781	7819	8809	9752	10644	11487	12282
	15	129	266	397	524	648	766	883	994	1101	1202	1297	1387
6		1063	2267	3433	4549	5645	6694	7697	8675	9630	10557	11449	12292
	23	120	256	388	514	637	756	869	979	1087	1192	1292	1387
8		992	2186	3354	4475	5578	6646	7665	8608	9535	10449	11339	12192
	30	112	247	379	505	630	750	865	972	1076	1176	1272	1364
10		897	2090	3259	4378	5482	6555	7602	8578	9482	10343	11168	11957
	38	101	236	368	494	619	740	858	968	1071	1168	1261	1350
12		807	1980	3138	4256	5365	6440	7494	8481	9403	10275	11100	11879
	45	91	224	354	481	606	727	846	957	1062	1160	1254	1344
14		693	1873	3028	4138	5218	6268	7318	8304	9235	10105	10915	11668
	53	78	211	342	467	589	708	826	937	1043	1141	1234	1323
16		554	1732	2882	3993	5083	6107	7118	8089	9032	9928	10778	11582
	61	63	196	325	451	574	689	804	913	1020	1120	1215	1306
18		409	1582	2738	3844	4924	5952	6956	7928	8874	9772	10622	11427
	68	46	179	309	434	556	672	785	895	1002	1103	1200	1293
20		355	1428	2587	3696	4767	5804	6813	7786	8732	9624	10472	11277
	76	40	161	292	417	538	655	769	879	986	1087	1184	1277
22		310	1259	2412	3518	4595	5619	6618	7589	8536	9438	10295	11107
	83	35	142	272	397	519	634	747	857	964	1065	1161	1253
25		958	2107	3215	4281	5310	6305	7264	8204	9110	9982	10819	11622
	95	108	238	363	483	599	712	820	926	1029	1129	1226	1319
30		521	1599	2696	3769	4804	5809	6776	7705	8617	9502	10369	11207
	114	59	181	304	425	542	656	765	870	973	1073	1169	1261

# Delta Series

## Performance Data

**649cm<sup>3</sup>/r [39.6 in<sup>3</sup>/r]**  
**ΔPressure Bar [PSI]**

		17 250	34 500	52 750	69 1000	86 1250	103 1500	121 1750	138 2000	155 2250
Flow LPM [GPM]	2	1365 154 10	2787 315 10	4156 469 10	5488 620 9	6775 765 9	7949 897 8	9102 1028 7	10174 1149 6	11100 1253 3
	7.6									
	4	1326 150 22	2770 313 22	4113 464 21	5400 610 20	6632 749 21	7819 883 20	8973 1013 19	10030 1132 19	11015 1244 18
	15									
	6	1258 142 35	2663 301 34	3998 451 33	5270 595 32	6521 736 32	7692 868 32	8774 991 32	9808 1107 32	10809 1220 31
	23									
	8	1154 130 47	2558 289 46	3902 441 45	5195 587 44	6455 729 42	7659 865 42	8775 991 42	9770 1103 43	10708 1209 43
	30									
	10	1045 118 58	2442 276 58	3787 428 57	5076 573 56	6331 715 55	7541 851 53	8691 981 53	9685 1093 54	10573 1194 55
	38									
	12	928 105 70	2321 262 70	3662 413 70	4939 558 68	6193 699 67	7385 834 66	8536 964 65	9577 1081 65	10469 1182 66
45										
14	740 84 82	2127 240 82	3469 392 82	4746 536 81	5989 676 80	7188 812 79	8352 943 77	9433 1065 76	10439 1179 76	
53										
16	614 69 93	1990 225 93	3318 375 93	4588 518 93	5795 654 92	6942 784 91	8081 912 90	9154 1033 89	10141 1145 90	
61										
18	448 51 105	1830 207 105	3158 356 105	4414 498 105	5619 634 104	6754 763 103	7853 887 102	8890 1004 102	9873 1115 104	
68										
20	281 32 117	1618 183 117	2944 332 117	4198 474 117	5410 611 117	6551 740 116	7653 864 114	8689 981 114	9676 1092 115	
76										
22	276 31 128	1518 171 128	2842 321 128	4099 463 128	5313 600 128	6453 728 128	7554 853 126	8596 970 125	9576 1081 126	
83										
25		1079 122 146	2393 270 146	3646 412 146	4834 546 146	5969 674 146	7071 798 145	8112 916 144	9105 1028 144	
95										
30		436 49 175	1747 197 175	3013 340 175	4225 477 175	5356 605 175	6454 729 174	7489 845 174	8479 957 175	
114										

-  Continuous
-  Intermittent
-  No operation

8479  
957  
175 } Torque lb-in  
Nm  
Speed RPM

**754cm<sup>3</sup>/r [46.0 in<sup>3</sup>/r]**  
**ΔPressure Bar [PSI]**

		17 250	34 500	52 750	69 1000	86 1250	103 1500	121 1750	138 2000
Flow LPM [GPM]	2	1561 176 9	3128 353 8	4605 520 8	6014 679 8	7422 838 7	8721 985 7	9978 1127 6	10910 1232 5
	7.6								
	4	1548 175 19	3142 355 18	4650 525 18	6029 681 18	7350 830 18	8605 971 18	9785 1105 17	10892 1230 17
	15								
	6	1470 166 30	3084 348 29	4608 520 28	6022 680 27	7346 829 27	8555 966 27	9722 1098 27	10850 1225 27
	23								
	8	1359 153 40	2975 336 39	4504 509 38	5925 669 38	7263 820 37	8488 958 36	9638 1088 37	10694 1207 38
	30								
	10	1240 140 50	2844 321 50	4364 493 49	5815 656 48	7185 811 47	8458 955 46	9603 1084 46	10584 1195 47
	38								
	12	1079 122 60	2686 303 60	4207 475 60	5641 637 59	7008 791 58	8248 931 57	9390 1060 57	10400 1174 57
45									
14	932 105 70	2512 284 70	4038 456 70	5477 618 70	6850 773 69	8124 917 68	9274 1047 67	10286 1161 67	
53									
16	753 85 80	2328 263 80	3834 433 80	5246 592 80	6577 742 80	7831 884 79	8999 1016 78	10040 1133 78	
61									
18	547 62 90	2119 239 90	3632 410 90	5024 567 90	6320 714 90	7551 852 90	8706 983 90	9721 1097 90	
68									
20	310 35 100	1919 217 100	3430 387 100	4826 545 100	6126 692 100	7339 829 100	8466 956 100	9430 1065 100	
76									
22	248 28 110	1666 188 110	3172 358 110	4571 516 110	5878 664 110	7102 802 110	8254 932 110	9269 1046 110	
83									
25		1261 142 126	2784 314 126	4191 473 126	5504 621 126	6727 759 126	7873 889 126	8911 1006 126	
95									
30		545 62 151	2055 232 151	3474 392 151	4800 542 151	6036 681 151	7175 810 151	8231 929 151	
114									

# Delta Series

Dimensions

Wheel Mount

## Ports

7/8 -14 UNF-2B SAE O-ring Ports

G 1/2 (BSP) Ports

## Standard Rotation Viewed from Shaft End

Port A Pressurized — CCW

Port B Pressurized — CW

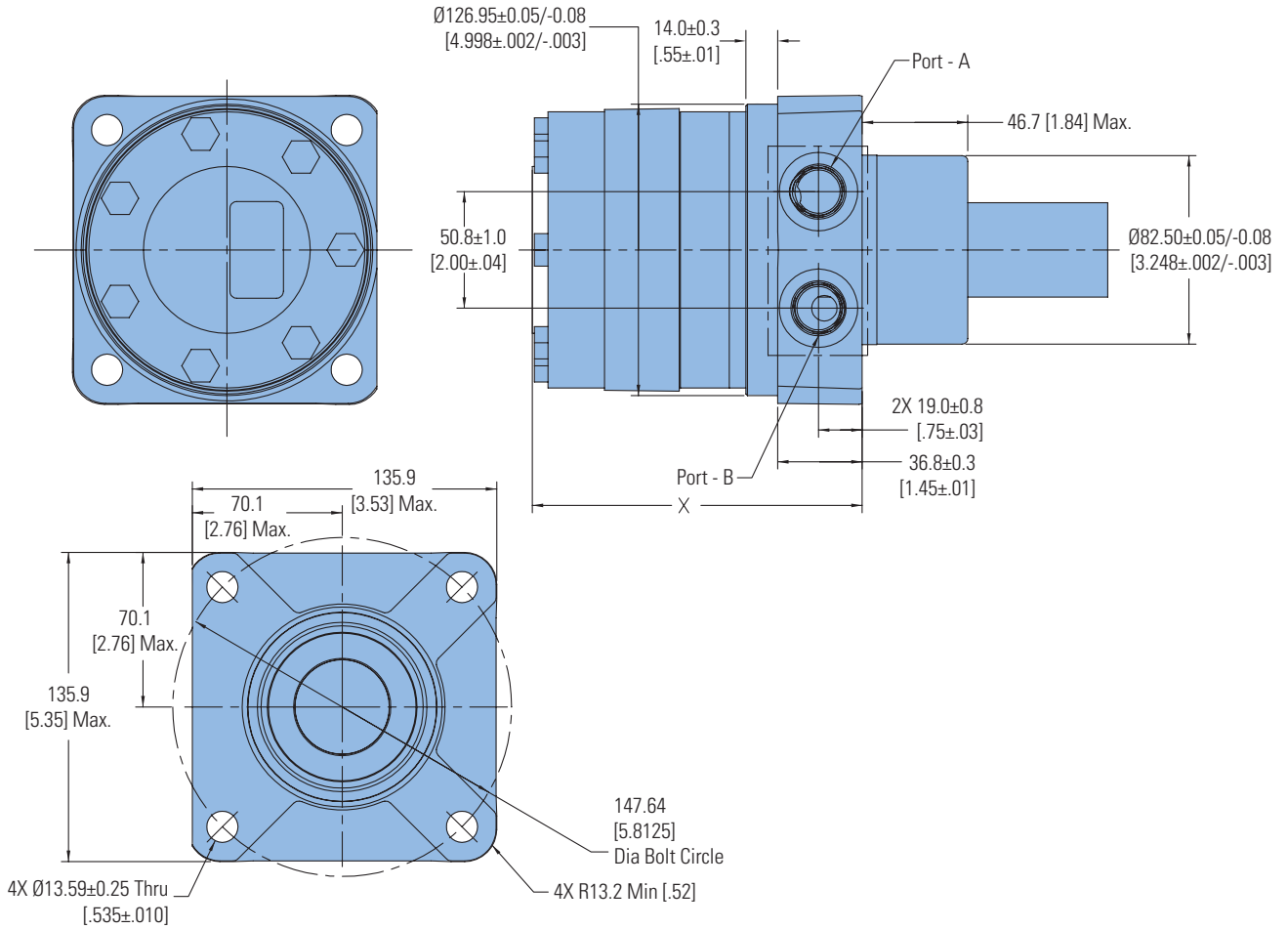

DISPLACEMENT CODE	X MAX	CODE	MAX
069	130.6 [5.14]	212	156.5 [6.16]
089	135.9 [5.35]	241	162.6 [6.40]
121	144.3 [5.68]	287	172.5 [6.79]
143	150.4 [5.92]	331	181.9 [7.16]
154	153.2 [6.03]	396	195.6 [7.70]
183	150.4 [5.92]	460	209.0 [8.23]

C-3

# Delta Series

## Dimensions

Standard Mount

## Ports

7/8 -14 UNF-2B SAE O-ring Ports

G 1/2 (BSP) Ports

## Standard Rotation Viewed from Shaft End

Port A Pressurized — CCW

Port B Pressurized — CW

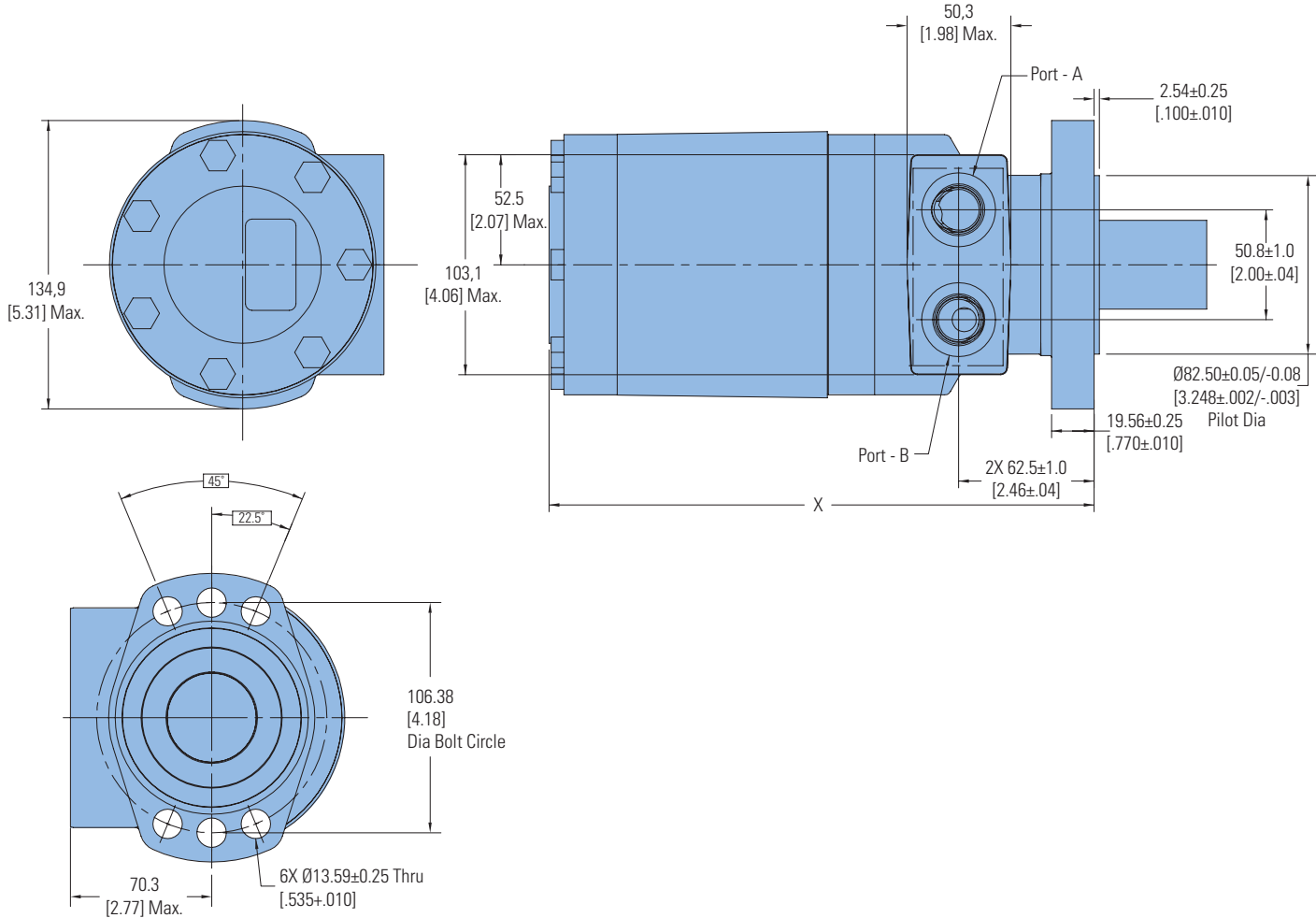

DISPLACEMENT CODE	X MAX	CODE	MAX
069	173.8 [6.84]	212	199.8 [7.87]
089	179.7 [7.08]	241	206.0 [8.11]
121	187.7 [7.39]	287	215.8 [8.50]
143	193.7 [7.63]	331	225.1 [8.86]
154	196.5 [7.74]	396	238.8 [9.40]
183	193.7 [7.63]	460	252.3 [9.93]

# Delta Series

## Dimensions

Shafts

### 1 1/2 Inch Straight

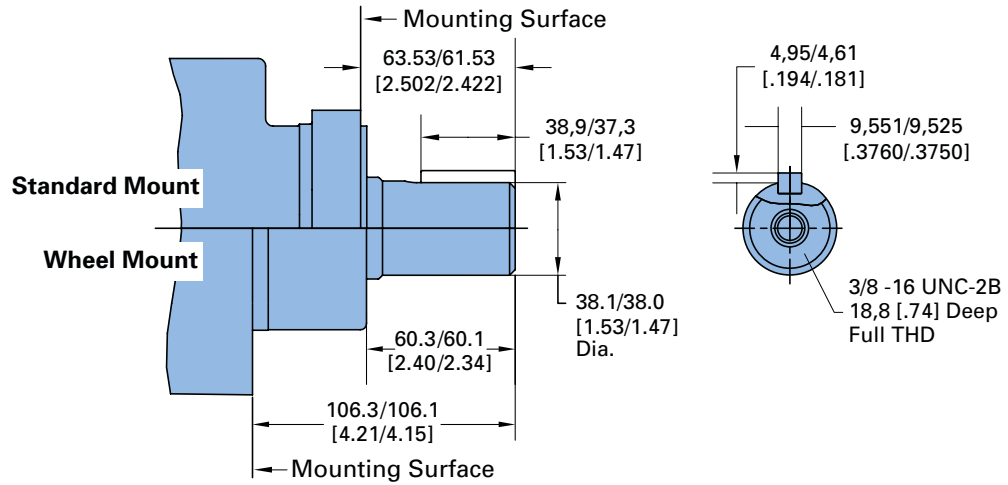

### 1 1/4 Inch 14 Tooth Splined

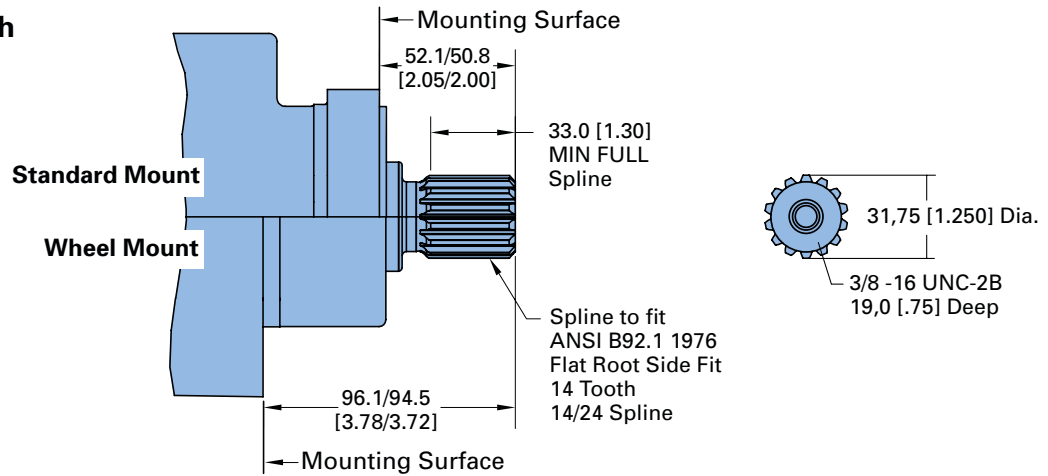

### 1 1/4 Inch Tapered

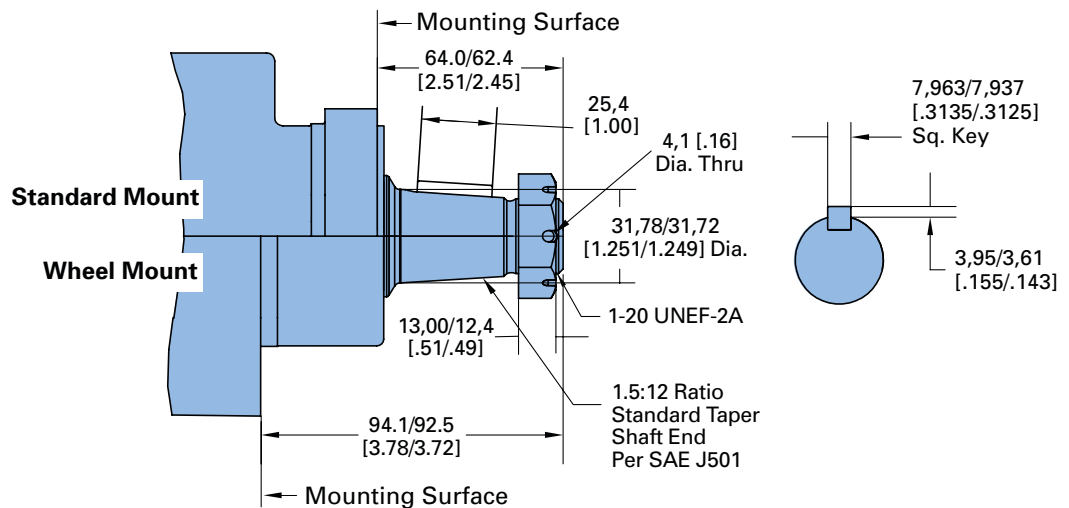

# Delta Series

## Shaft Side Load Capacity

These curves indicate the radial load capacity on the motor shaft(s) at various locations.

**Each curve is based on B 10 bearing life (2000 hours of 12,000,000 shaft revolutions at 100 RPM) at rated output torque.**

To determine radial load at speeds other than 100 RPM, multiply the load values given on the bearing curve by the factors in the chart below.

RPM	Multiplication Factor
50	1.23
100	1.00
200	0.81
300	0.72
400	0.66
500	0.62
600	0.58
700	0.56
800	0.54

### Side Load Chart for Standard Mount

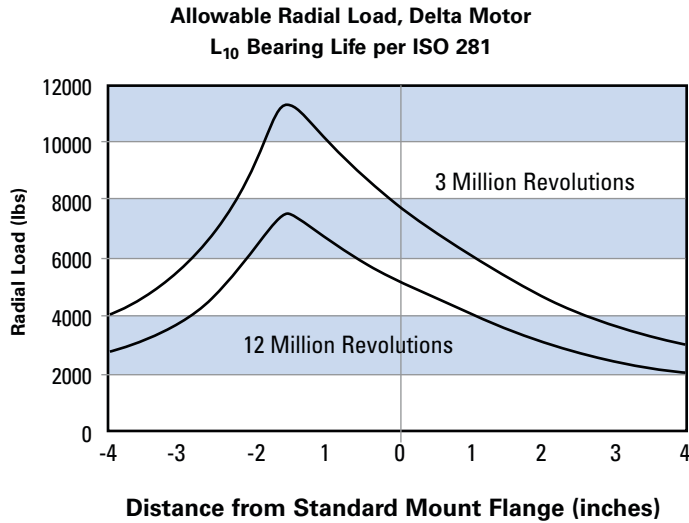

### Side Load Chart for Wheel Mount

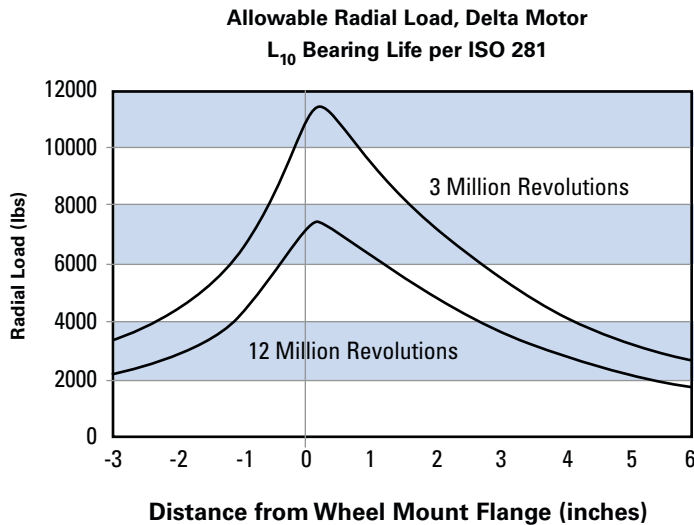

# Delta Series

## Product Numbers

### Note:

For Delta Series Motors with a configuration **Not Shown** in the charts below contact your Eaton Representative.

Mounting	Shaft	Port Size	Timing	Displacement $\text{cm}^3/\text{r}$ [ $\text{in}^3/\text{r}$ ] / Product Number					
				113 [6.9]	146 [8.9]	198 [12.1]	234 [14.3]		
Wheel Motor	1-1/4 Inch Tapered	7/8" O-ring	Standard -CCW	184-0005-002	184-0006-002	184-0002-002	184-0001-002		
			Standard -CW	184-0025-002	184-0026-002	184-0027-002	184-0028-002		
	1-1/2 Inch 17 T Splined	7/8" O-ring	Standard -CCW	184-0013-002	184-0014-002	184-0015-002	184-0016-002		
			Standard -CW	184-0037-002	184-0038-002	184-0039-002	184-0040-002		
	Wheel Motor	1-1/4 Inch Tapered	7/8" O-ring	Standard -CCW	184-0003-002	184-0004-002	184-0007-002	184-0008-002	
				Standard -CW	184-0029-002	184-0030-002	184-0031-002	184-0032-002	
		1-1/2 Inch 17 T Splined	7/8" O-ring	Standard -CCW	184-0017-002	184-0018-002	184-0019-002	184-0020-002	
				Standard -CW	184-0041-002	184-0042-002	184-0043-002	184-0044-002	
		Wheel Motor	1-1/4 Inch Tapered	7/8" O-ring	Standard -CCW	184-0009-002	184-0010-002	184-0011-002	184-0012-002
					Standard -CW	184-0033-002	184-0034-002	184-0035-002	184-0036-002
			1-1/2 Inch 17 T Splined	7/8" O-ring	Standard -CCW	184-0021-002	184-0022-002	184-0023-002	184-0024-002
					Standard -CW	184-0045-002	184-0046-002	184-0047-002	184-0048-002



# Delta Series

## Model Code

The following 26-digit coding system has been developed to identify all of the configuration options for the Delta Low Speed High Torque motor. Use this model code to specify a motor with the desired features. All 26 digits of the code must be present when ordering. You may want to photocopy the matrix below to ensure that each number is entered in the correct box.

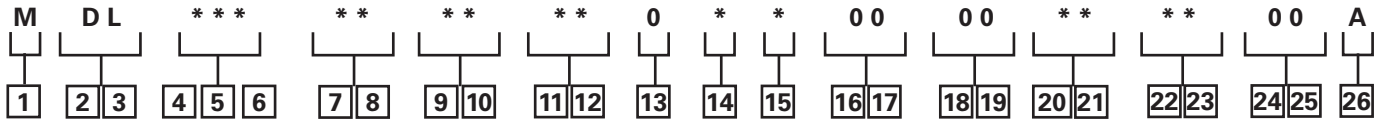

### 1 Product

M – Motor

### 2, 3 Series

DL – Delta Series

### 4, 5, 6 Displacement cm<sup>3</sup>/r [in<sup>3</sup>/r]

069 – 113 [ 6.9]

089 – 146 [ 8.9]

121 – 198 [12.1]

143 – 234 [14.3]

154 – 252 [15.4]

183 – 300 [18.3]

212 – 347 [21.2]

241 – 395 [24.1]

287 – 470 [28.7]

331 – 542 [33.1]

396 – 649 [39.6]

460 – 754 [46.0]

### 7, 8 Mounting Type

AA – Wheel, 4 Bolt: 82.6 [3.25] Pilot Dia. 13.59 [.535] Dia. Holes On 147.6 [5.81] Dia. Bolt Circle. 127.0 [5.00] Dia. Rear Mount Pilot

AB – Standard, 6 Bolt: 82.6 [3.25] Pilot Dia. 13.59 [.535] Dia. Holes on 106.4 [4.19] Dia. Bolt Circle. .100 [2.54] Pilot Length. Sae A, Magneto

AC – Standard, 6 Bolt: 82.6 [3.25] Pilot Dia. 13.59 [.535] Dia. Holes on 106.4 [4.19] Dia. Bolt Circle. .250 [6.35] Pilot Length. SAE A, Magneto

### 9, 10 Output Shaft

01 – 38.10 [1.500] Dia. Straight with .375-16 UNC-2B Thread, and 9.52 [.375] Sq x 25.40 [1.000] Straight Key

02 – 31.75 [1.250] Dia. .125:1 Tapered Shaft per SAE J501 with 1.000-20 UNEF-2A Threaded Shaft End and Slotted Hex Nut, 7.938 [.3125] Sq x 25.40 [1.000] Straight Key

03 – 41.30 [1.626] Dia. .125:1 Tapered Shaft per SAE J501 with 1.250-18 UNEF-2A Threaded Shaft End and Slotted Hex Nut, 11.125 [.4380] Sq x 34.04 [1.340] Straight Key

04 – 31.75 [1.250] Dia. Flat Root Side Fit, 14 Tooth, 12/24 DP 30 Deg. Involute Spline with .375-16 UNC-2B Thread in End, 33.0 [1.30] Minimum Full Spline Length

05 – 38.10 [1.500] Dia. Flat Root Side Fit, 17 Tooth, 12/24 DP 30 Deg. Involute Spline, 31.8 [1.25] Minimum Full Spline Length, with .375-16 UNC-2B Thread in End

06 – 38.10 [1.500] Dia. Tapered Shaft per SAE J501 with 1.000-20 UNEF-2A Thread in End, 7.938 [.3125] Sq x 31.75 [1.250] Key

### 11, 12 Ports

AA – .875-14 UNF-2B SAE O-Ring

AC – G 1/2 BSP Straight Thread

### 13 Pressure/Flow Option

0 – None

### 14 Geroler Option

0 – Standard

B – Tight Fitting Geroler

### 15 Seal Option

00 – Standard Seals

02 – Seal Guard

03 – Viton Seals

04 – Viton Shaft Seal

11 – High pressure shaft seal, slinger seal

19 – Extreme duty seal guard

### 16, 17 Accessories

00 – None

### 18, 19 Special Features (Hardware)

00 – None

### 20, 21 Special Features (Assembly)

00 – Standard Rotation - CCW

01 – Standard Rotation - CW

### 22, 23 Paint/Packaging

AA - No Paint, Individual Box

AB - Low Gloss Black Primer, Individual Box

AC - Epoxy Coated (Frost Gray), Individual Box

AE - No Paint, Bulk Box

AF - Low Gloss Black Primer, Bulk Box

### 24, 25 Customer Identification

00 – None

### 26 Design Code

B – Two (2)

Feature in **bold** are preferred and allow for shorter lead time.

# 4000 Series

## Highlights

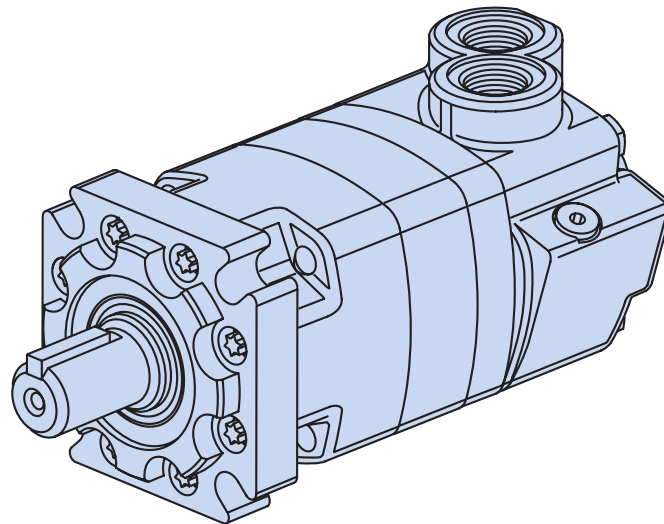

### Features

- 10 displacements, a variety of mounting flanges and output shafts
- Reliable, proven design
- High efficiency
- Environmental protection options

### Benefits

- Flexibility in designing this motor into a system
- Options that fit well into tough applications

### Applications

- Mowing
- Snow Removal
- Sprayer
- Trencher
- Wood Products

### Description

The 4000 Series offers up to 8600 in-lb of torque and 25 gpm (continuous ratings). This is the corner stone of the Char-Lynn line.

### 4000 Series Motors

Geroler Element	10 Displacements
Flow l/min [GPM]	95 [25] Continuous**
	150 [40] Intermittent*
Speed RPM	722 Cont.**
	868 Inter.*
Pressure bar [PSI]	200 [3000] Cont.**
	300 [4500] Inter.*
Torque Nm [lb-in]	970 [8600] Cont.**
	1180 [10450] Inter.*

\*\* Continuous— (Cont.) Continuous rating, motor may be run continuously at these ratings

\* Intermittent— (Inter.) Intermittent operation, 10% of every minute.

C-4



Mowing



Snow Removal



Sprayer



Trencher

# 4000 Series

## Specifications

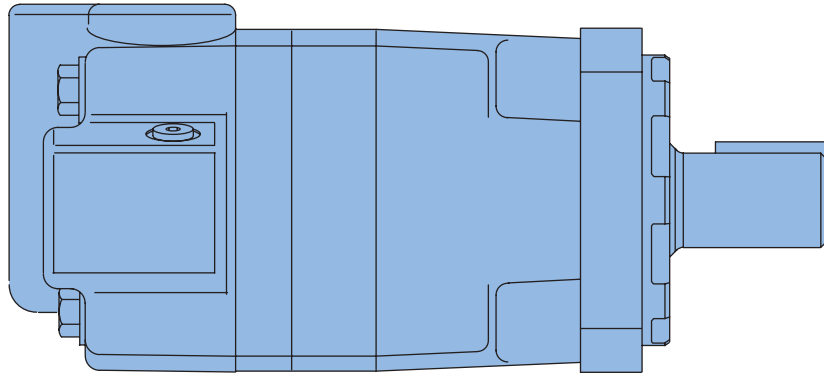

### 4000 SERIES MOTORS

Displ. cm <sup>3</sup> /r [in <sup>3</sup> /r]		110 [ 6.7]	130 [ 7.9]	160 [ 9.9]	205 [12.5]	245 [15.0]	280 [17.1]	310 [19.0]	395 [24.0]	495 [30.0]	625 [38.0]
Max. Speed (RPM)	Continuous	697	722	582	459	383	336	303	239	191	151
	Intermittent @ Flow	868	862	693	546	532	488	422	376	305	241
Flow l/min [GPM]	Continuous	75 [20]	95 [25]	95 [25]	95 [25]	95 [25]	95 [25]	95 [25]	95 [25]	95 [25]	95 [25]
	Intermittent	95 [25]	115 [30]	115 [30]	115 [30]	130 [35]	130 [35]	130 [35]	150 [40]	150 [40]	150 [40]
Torque* Nm [lb-in]	Continuous	320 [2850]	375 [3330]	485 [4290]	600 [5300]	705 [6240]	753 [6666]	850 [7530]	930 [8240]	945 [8375]	970 [8605]
	Intermittent	470 [4160]	560 [4940]	705 [6240]	800 [7100]	845 [7470]	957 [8471]	1065 [9420]	1185 [10470]	1170 [10350]	1180 [10450]
Pressure Δ bar [Δ PSI]	Continuous	205 [3000]	205 [3000]	205 [3000]	205 [3000]	205 [3000]	205 [3000]	205 [3000]	190 [2750]	140 [2000]	115 [1700]
	Intermittent	310 [4500]	310 [4500]	310 [4500]	260 [3750]	310 [4500]	260 [3750]	260 [3750]	240 [3500]	170 [2500]	140 [2000]
	Peak	310 [4500]	310 [4500]	310 [4500]	310 [4500]	310 [4500]	310 [4500]	310 [4500]	295 [4250]	230 [3300]	180 [2600]
Weight kg [lb]	Standard or Wheel Mount	17.9 [39.5]	18.1 [40.0]	18.1 [40.0]	18.4 [40.5]	18.6 [41.0]	19.1 [42.0]	19.5 [43.0]	20.4 [45.0]	21.8 [48.0]	23.1 [51.0]
	Bearingless		14.1 [31.0]	14.3 [31.5]	14.1 [31.0]	14.5 [32.0]	14.7 [32.5]	15.2 [33.5]	15.6 [34.5]	16.6 [36.5]	17.9 [39.5]

Maximum Case Pressure: See case pressure seal limitation graph.

\*See shaft torque ratings for limitations..

#### Note:

To assure best motor life, run motor for approximately one hour at 30% of rated pressure before application to full load. Be sure motor is filled with fluid prior to any load applications.

#### Maximum Inlet Pressure:

310 bar [4500 PSI]  
Do not exceed Δ pressure rating (see chart above).

#### Maximum Return Pressure:

310 bar [4500 PSI] with case drain line installed.  
Do not exceed Δ pressure rating (see chart above).

#### Δ bar [Δ PSI] :

The true pressure difference between inlet port and outlet port

#### Continuous Rating:

Motor may be run continuously at these ratings

#### Intermittent Operation:

10% of every minute

#### Peak Operation:

1% of every minute

#### Recommended Fluids:

Premium quality, anti-wear type hydraulic oil with a viscosity of not less than 70 SUS at operating temperature.

#### Recommended System Operating Temp.:

-34°C to 82°C [-30°F to 180°F]

#### Recommended Filtration:

per ISO Cleanliness Code, 4406: 20/18/13

# 4000 Series

## Performance Data

Motors run with high efficiency in all areas designated with a number for torque and speed. For best motor life select a motor to run with a torque and speed range shown in the light shaded area.

Performance data is typical at 120 SUS. Actual data may vary slightly from unit to unit in production.

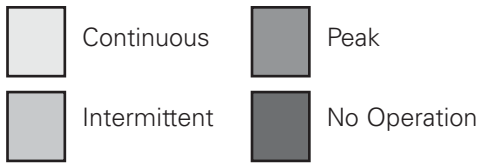

**130cm<sup>3</sup>/r [7.9 in<sup>3</sup>/r]**  
**ΔPressure Bar [PSI]**

	[250] 155	[500] 35	[1000] 70	[1500] 105	[2000] 140	[2500] 170	[3000] 205	[3500] 240	[4000] 275	[4500] 310
[.5] 1.9	[310] 35 12	[510] 60 9	[1060] 120 5	[1590] 180 2						
[1] 3.8	[290] 35 30	[530] 60 28	[1080] 120 25	[1600] 180 19	[2110] 240 14	[2640] 300 13	[3060] 345 12	[3450] 390 4		
[2] 7.5	[280] 30 57	[530] 60 56	[1100] 125 53	[1620] 185 47	[2140] 240 42	[2660] 300 40	[3180] 360 38	[3600] 405 29	[4020] 455 20	[4080] 460 12
[4] 15	[260] 30 116	[520] 60 114	[1100] 125 111	[1650] 185 105	[2200] 250 100	[2700] 305 95	[3210] 365 90	[3660] 415 70	[4100] 465 50	[4560] 515 37
[6] 23	[240] 25 173	[510] 60 170	[1100] 125 167	[1650] 185 161	[2200] 250 156	[2720] 305 149	[3240] 365 142	[3710] 420 123	[4180] 470 104	[4660] 525 91
[8] 30	[230] 25 228	[510] 60 225	[1080] 120 222	[1640] 185 216	[2210] 250 210	[2740] 310 202	[3270] 370 194	[3770] 425 176	[4270] 480 158	[4750] 535 145
[10] 38	[210] 25 283	[510] 60 225	[1080] 120 278	[1640] 185 272	[2210] 250 266	[2750] 310 256	[3300] 375 246	[3820] 430 229	[4350] 490 212	[4840] 545 189
[12] 45	[200] 25 341	[500] 55 338	[1070] 120 335	[1640] 185 329	[2220] 250 323	[2750] 310 312	[3300] 375 300	[3840] 435 282	[4370] 495 263	[4870] 550 237
[14] 53	[180] 20 400	[490] 55 396	[1060] 120 392	[1640] 185 386	[2220] 250 380	[2750] 310 368	[3310] 375 355	[3860] 435 335	[4390] 495 366	[4890] 550 286
[16] 61	[160] 20 457	[490] 55 453	[1050] 120 449	[1630] 185 443	[2220] 250 437	[2760] 310 424	[3310] 375 410	[3860] 435 388	[4400] 495 366	[4920] 555 335
[18] 68	[130] 15 516	[480] 55 511	[1050] 120 506	[1630] 185 500	[2220] 250 494	[2760] 310 480	[3320] 375 465	[3870] 435 442	[4420] 500 418	[4940] 560 384
[20] 76	[110] 10 574	[470] 55 569	[1040] 120 564	[1620] 185 559	[2210] 250 551	[2760] 310 536	[3330] 375 520	[3890] 440 495	[4440] 500 470	
[22] 83	[70] 10 633	[450] 50 628	[1020] 115 624	[1610] 180 615	[2190] 245 606	[2750] 310 590	[3320] 375 573	[3880] 440 547	[4440] 500 520	
[25] 95	[50] 5 722	[430] 50 718	[1000] 115 714	[1580] 180 702	[2160] 245 690	[2720] 305 672	[3300] 375 653	[3860] 435 625	[4430] 500 595	
[30] 114		[400] 45 862	[940] 105 855	[1500] 170 842	[2080] 235 827	[2670] 300 806	[3200] 360 783	[3740] 425 749		

**110cm<sup>3</sup>/r [6.7 in<sup>3</sup>/r]**  
**ΔPressure Bar [PSI]**

	[250] 155	[500] 35	[1000] 70	[1500] 105	[2000] 140	[2500] 170	[3000] 205	[3500] 240	[4000] 275	[4500] 310
[.5] 1.9	[150] 15 14	[390] 45 10	[850] 95 5	[1290] 145 2						
[1] 3.8	[170] 20 34	[440] 50 33	[900] 100 31	[1380] 155 28	[1860] 210 25	[2270] 255 22	[2680] 305 18	[3110] 350 11		
[2] 7.5	[180] 20 68	[450] 50 67	[910] 105 62	[1390] 155 56	[1860] 210 50	[2280] 260 44	[2700] 305 36	[3120] 355 28	[3450] 390 18	
[4] 15	[190] 20 138	[460] 50 136	[940] 105 123	[1400] 160 110	[1870] 210 97	[2310] 260 84	[2730] 310 70	[3140] 355 56	[3560] 400 42	[3880] 440 28
[6] 23	[200] 25 207	[470] 55 204	[960] 110 200	[1420] 160 193	[1880] 210 184	[2320] 260 174	[2760] 310 163	[3200] 360 150	[3640] 410 136	[3950] 455 121
[8] 30	[190] 20 277	[460] 50 274	[950] 105 270	[1420] 160 262	[1880] 210 253	[2340] 265 241	[2790] 315 228	[3230] 365 213	[3670] 415 196	[4010] 455 179
[10] 38	[180] 20 347	[460] 50 344	[950] 105 340	[1420] 160 331	[1890] 215 322	[2350] 265 308	[2820] 320 292	[3260] 370 274	[3700] 420 255	[4070] 460 236
[12] 45	[160] 20 417	[450] 50 414	[940] 105 410	[1420] 160 400	[1880] 210 390	[2350] 265 374	[2820] 320 355	[3260] 370 335	[3710] 420 313	[4080] 460 292
[14] 53	[140] 15 487	[440] 50 484	[930] 105 480	[1420] 160 469	[1880] 210 458	[2350] 265 440	[2830] 320 419	[3280] 370 446	[3730] 420 471	[4110] 465 348
[16] 61	[130] 15 556	[440] 50 553	[920] 105 549	[1410] 160 537	[1870] 210 525	[2350] 265 505	[2840] 320 482	[3300] 375 455	[3750] 425 428	[4120] 465 404
[18] 68	[100] 10 626	[440] 50 622	[910] 105 618	[1400] 160 606	[1870] 210 593	[2350] 265 570	[2840] 320 545	[3300] 375 516	[3770] 425 485	[4140] 465 460
[20] 76	[80] 10 697	[430] 50 694	[900] 100 690	[1370] 155 677	[1860] 210 664	[2350] 265 638	[2850] 320 611	[3320] 375 579	[3790] 430 545	[4160] 470 518
[25] 95										

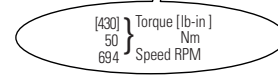

# 4000 Series

## Performance Data

Motors run with high efficiency in all areas designated with a number for torque and speed. For best motor life select a motor to run with a torque and speed range shown in the light shaded area.

Performance data is typical at 120 SUS. Actual data may vary slightly from unit to unit in production.

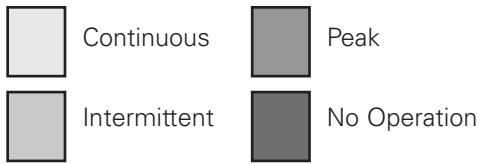

**205cm<sup>3</sup>/r [17.1 in<sup>3</sup>/r]**  
ΔPressure Bar [PSI]

	[250] 15	[500] 35	[1000] 70	[1500] 105	[2000] 140	[2500] 170	[3000] 205	[3500] 240	[4000] 275	[4500] 310
[.5] 1.9	[400] 45 8	[810] 90 5	[1500] 170 1							
[1] 3.8	[410] 45 17	[830] 95 17	[1590] 180 16	[2220] 250 15	[2860] 325 14	[3860] 435 12	[4560] 515 11	[5390] 610 9	[5510] 625 3	
[2] 7.5	[420] 45 36	[850] 95 35	[1680] 190 34	[2410] 270 32	[3140] 355 29	[4060] 460 27	[4800] 540 25	[5420] 610 22	[6000] 680 16	[6210] 700 8
[4] 15	[430] 50 73	[870] 100 73	[1770] 200 71	[2590] 295 70	[3140] 385 68	[4260] 480 61	[5040] 570 57	[5730] 645 45	[6340] 715 35	[6740] 760 23
[6] 23	[430] 50 107	[880] 100 106	[1800] 205 105	[2620] 295 103	[3530] 400 101	[4370] 495 98	[5170] 585 90	[5900] 665 81	[6590] 745 74	[7100] 800 65
[8] 30	[410] 45 144	[870] 100 143	[1820] 205 142	[2660] 300 138	[3560] 400 136	[4410] 500 132	[5240] 590 125	[6020] 680 116	[6770] 765 109	
[10] 38	[390] 45 182	[860] 95 180	[1820] 205 179	[2700] 305 174	[3580] 405 170	[4460] 505 166	[5300] 600 160	[6110] 690 152	[6890] 780 143	
[12] 45	[350] 40 217	[850] 95 216	[1810] 205 215	[2690] 305 211	[3570] 405 202	[4440] 500 200	[5300] 600 194	[6120] 690 185		
[14] 53	[330] 35 256	[840] 95 254	[1790] 200 252	[2670] 300 248	[3560] 400 243	[4430] 500 237	[5290] 600 229	[6120] 690 219		
[16] 61	[290] 35 291	[820] 95 290	[1770] 200 289	[2650] 300 284	[3540] 400 280	[4410] 500 272	[5280] 595 264	[6120] 690 253		
[18] 68	[270] 30 329	[810] 90 327	[1750] 200 325	[2640] 300 321	[3520] 400 316	[4400] 495 308	[5270] 595 298	[6120] 690 287		
[20] 76	[230] 25 366	[800] 90 364	[1730] 195 362	[2620] 295 358	[3510] 395 353	[4380] 495 345	[5270] 595 334	[6120] 690 321		
[22] 83	[190] 20 402	[780] 90 400	[1690] 190 398	[2600] 295 394	[3500] 395 389	[4370] 495 380	[5260] 595 368			
[25] 95	[150] 15 459	[750] 85 456	[1640] 185 453	[2560] 290 448	[3480] 395 442	[4360] 495 434	[5240] 590 421			
[30] 114	[710] 80 546	[1540] 175 542	[2510] 285 537	[3350] 380 529	[4190] 475 520	[5030] 570 504				

**160cm<sup>3</sup>/r [9.9 in<sup>3</sup>/r]**  
ΔPressure Bar [PSI]

	[250] 15	[500] 35	[1000] 70	[1500] 105	[2000] 140	[2500] 170	[3000] 205	[3500] 240	[4000] 275	[4500] 310
[.5] 1.9	[300] 35 8	[680] 75 7	[1320] 150 5	[2050] 230 3	[2750] 310 1					
[1] 3.8	[320] 35 23	[700] 80 22	[1350] 155 20	[2070] 235 19	[2780] 315 18	[3300] 375 16	[3940] 445 15	[4410] 500 8	[4950] 560 2	
[2] 7.5	[330] 35 46	[700] 80 45	[1360] 155 41	[2080] 235 40	[2790] 315 37	[3340] 375 32	[3970] 450 29	[4530] 510 27	[5090] 575 25	[5590] 630 13
[4] 15	[320] 35 93	[710] 80 92	[1400] 160 90	[2100] 240 88	[2820] 320 84	[3420] 385 76	[4020] 455 73	[4620] 520 62	[5220] 590 51	[5730] 645 35
[6] 23	[300] 35 137	[710] 80 135	[1420] 160 134	[2140] 240 131	[2850] 320 126	[3510] 395 120	[4180] 470 114	[4760] 540 90	[5340] 605 75	[5870] 665 57
[8] 30	[280] 30 184	[720] 80 182	[1450] 165 180	[2180] 245 176	[2900] 330 171	[3560] 400 163	[4230] 480 154	[4850] 550 138	[5470] 620 122	[6010] 680 100
[10] 38	[260] 30 232	[720] 80 229	[1480] 165 226	[2220] 250 221	[2950] 335 216	[3610] 410 206	[4290] 485 194	[4920] 555 182	[5560] 630 169	[6160] 695 142
[12] 45	[240] 25 277	[700] 80 274	[1450] 165 272	[2190] 245 266	[2920] 330 260	[3590] 405 250	[4280] 485 238	[4920] 555 224	[5570] 630 209	[6180] 700 182
[14] 53	[220] 25 321	[680] 75 319	[1420] 160 318	[2160] 245 311	[2890] 325 304	[3570] 405 294	[4270] 480 282	[4920] 555 266	[5580] 630 249	[6200] 700 222
[16] 61	[200] 25 366	[670] 75 364	[1400] 160 362	[2130] 240 356	[2860] 325 348	[3550] 400 338	[4260] 480 326	[4920] 555 308	[5590] 630 289	[6220] 705 262
[18] 68	[180] 20 410	[650] 75 409	[1360] 155 407	[2100] 235 401	[2830] 320 392	[3530] 400 382	[4250] 480 370	[4910] 555 350	[5600] 635 329	[6240] 705 302
[20] 76	[150] 15 460	[630] 70 458	[1340] 150 456	[2070] 235 448	[2800] 315 440	[3510] 395 429	[4240] 480 417	[4910] 555 396	[5610] 635 373	
[22] 83	[120] 15 509	[620] 70 506	[1330] 150 502	[2060] 235 494	[2790] 315 484	[3500] 395 473	[4220] 475 461	[4910] 555 438	[5600] 635 413	
[25] 95	[70] 10 582	[600] 70 578	[1320] 150 573	[2050] 230 563	[2780] 315 552	[3480] 395 540	[4210] 475 526	[4900] 555 501	[5590] 630 474	
[30] 114	[560] 65 693	[1280] 145 687	[1990] 225 675	[2700] 305 661	[3430] 390 647	[3970] 450 630	[4640] 525 600			

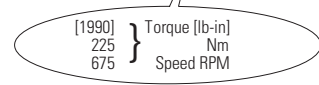

# 4000 Series

245cm<sup>3</sup>/r [15.0 in<sup>3</sup>/r]  
ΔPressure Bar [PSI]

## Performance Data

Motors run with high efficiency in all areas designated with a number for torque and speed. For best motor life select a motor to run with a torque and speed range shown in the light shaded area.

Performance data is typical at 120 SUS. Actual data may vary slightly from unit to unit in production.

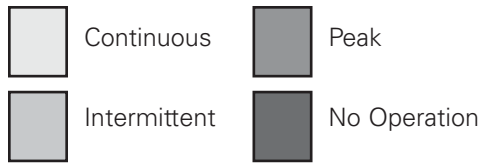

	[250] 15	[500] 35	[750] 50	[1000] 70	[1250] 85	[1500] 105	[1750] 120	[2000] 140	[2250] 15	[2500] 170	[2750] 190	[3000] 205	[3250] 225	[3500] 240	[3750] 260
[.5]	[460] 50 5	[980] 110 2													
[1]	[480] 55 14	[990] 110 14	[1490] 170 14	[1990] 225 13	[2480] 280 13	[2970] 335 12	[3400] 385 12	[3830] 435 11	[4250] 480 11	[4680] 530 10	[5020] 565 4				
[2]	[500] 55 30	[1000] 115 30	[1520] 170 29	[2040] 230 29	[2540] 285 28	[3050] 345 27	[3420] 385 26	[3930] 445 24	[4440] 500 23	[4900] 555 22	[5320] 600 20	[5740] 650 18	[6160] 695 16	[6640] 750 14	[7150] 810 11
[4]	[510] 60 61	[1030] 115 61	[1560] 175 60	[2080] 235 60	[2600] 295 59	[3130] 355 59	[3630] 410 58	[4130] 465 56	[4630] 525 53	[5120] 580 49	[5570] 630 47	[6030] 680 44	[6480] 730 42	[6870] 775 39	[7340] 830 36
[6]	[510] 60 91	[1040] 120 90	[1570] 175 90	[2100] 235 89	[2620] 295 88	[3160] 355 88	[3660] 415 86	[4200] 475 83	[4710] 530 80	[5220] 590 75	[5690] 645 72	[6140] 695 70	[6620] 750 67	[7050] 815 63	[7430] 840 59
[8]	[500] 55 121	[1020] 115 121	[1560] 175 120	[2110] 240 119	[2630] 295 118	[3150] 355 117	[3680] 415 115	[4210] 475 113	[4740] 535 111	[5250] 595 106	[5720] 645 103	[6200] 700 99	[6670] 755 96	[7090] 800 91	[7470] 845 87
[10]	[470] 55 152	[1000] 115 151	[1540] 175 150	[2100] 235 148	[2620] 295 148	[3150] 355 147	[3690] 415 145	[4230] 480 143	[4770] 540 141	[5290] 600 137	[5670] 650 133	[6240] 705 129	[6710] 760 125	[7140] 805 120	
[12]	[450] 50 183	[980] 110 182	[1530] 175 180	[2080] 235 179	[2610] 295 178	[3140] 355 178	[3680] 415 176	[4220] 475 173	[4760] 540 170	[5280] 595 166	[5750] 645 161	[6230] 705 157	[6700] 755 152		
[14]	[420] 45 213	[960] 110 212	[1520] 170 211	[2060] 235 210	[2600] 295 209	[3130] 355 208	[3670] 415 206	[4200] 475 203	[4740] 535 200	[5260] 595 195	[5740] 650 190	[6220] 705 185			
[16]	[400] 45 244	[950] 105 243	[1500] 170 242	[2040] 230 241	[2580] 290 240	[3120] 355 239	[3660] 415 236	[4190] 475 232	[4730] 540 229	[5250] 595 225	[5730] 650 219	[6210] 700 213			
[18]	[380] 45 275	[930] 105 274	[1480] 165 273	[2020] 230 272	[2560] 290 270	[3110] 350 269	[3650] 415 266	[4180] 470 262	[4710] 530 259	[5230] 590 254	[5720] 645 248	[6200] 700 241			
[20]	[350] 40 305	[910] 105 305	[1460] 165 304	[2000] 225 302	[2550] 290 300	[3100] 350 300	[3640] 410 296	[4170] 470 292	[4700] 530 288	[5220] 590 283	[5710] 645 276				
[22]	[310] 35 337	[870] 100 336	[1420] 160 335	[1970] 225 334	[2500] 280 332	[3050] 345 330	[3590] 405 326	[4140] 465 323	[4680] 530 319	[5200] 590 313	[5680] 645 306				
[25]	[260] 30 383	[820] 95 382	[1380] 155 381	[1930] 220 380	[2460] 280 378	[2980] 335 376	[3540] 400 372	[4090] 465 369	[4640] 525 365	[5180] 585 357					
[30]		[680] 75 457	[1250] 140 456	[1860] 210 455	[2390] 270 453	[2900] 330 450	[3430] 390 445	[3960] 445 442	[4460] 505 437	[4950] 560 427					
[35]			[1110] 125 532	[1740] 195 531	[2270] 255 528	[2790] 315 525	[3340] 375 519	[3910] 440 515	[4400] 495 509						
[132]															

280cm<sup>3</sup>/r [17.1 in<sup>3</sup>/r]  
ΔPressure Bar [PSI]

	[250] 15	[500] 35	[750] 50	[1000] 70	[1250] 85	[1500] 105	[1750] 120	[2000] 140	[2250] 155	[2500] 170	[2750] 190	[3000] 205	[3250] 225	[3500] 240	[3750] 260
[.5]	[533] 60 4	[1074] 121 2													
[1]	[553] 62 12	[1136] 128 12	[1714] 194 12	[2287] 258 11	[2841] 321 11	[3394] 384 11	[3868] 437 10	[4389] 496 10	[4895] 553 10	[6080] 685 8	[5870] 663 6	[6811] 770 6	[7239] 818 5	[7654] 865 4	
[2]	[568] 64 26	[1146] 130 26	[1740] 197 25	[2328] 263 25	[2902] 328 24	[3461] 391 24	[3955] 447 23	[4524] 511 22	[5222] 590 21	[6300] 713 20	[6146] 694 19	[6666] 753 17	[7191] 813 15	[7749] 876 13	[8323] 940 13
[4]	[579] 65 53	[1167] 132 53	[1771] 200 52	[2374] 268 51	[2962] 335 51	[3557] 399 51	[4139] 468 50	[4712] 532 49	[5285] 597 47	[6395] 722 45	[6248] 705 44	[6959] 785 42	[7502] 848 41	[8020] 906 40	[8471] 957 38
[6]	[583] 66 79	[1177] 133 79	[1781] 201 78	[2395] 271 78	[2987] 338 77	[3601] 407 77	[4193] 474 76	[4793] 542 72	[5367] 607 72	[6521] 737 69	[6321] 717 67	[7082] 800 66	[7607] 859 65	[8097] 915 64	
[8]	[573] 65 106	[1167] 132 106	[1780] 201 105	[2404] 272 105	[3007] 340 104	[3610] 408 104	[4218] 477 102	[4812] 544 101	[5411] 611 99	[6594] 741 96	[6356] 717 94	[7222] 813 92	[7518] 849 90		
[10]	[547] 62 134	[1146] 130 133	[1765] 199 133	[2395] 271 131	[2997] 339 131	[3629] 410 130	[4238] 479 129	[4837] 547 127	[5442] 615 126	[6635] 746 122	[6401] 727 119	[7222] 813 115	[7518] 849 111		
[12]	[527] 60 161	[1126] 127 160	[1745] 197 186	[2369] 268 158	[2991] 338 157	[3609] 408 157	[4228] 478 154	[4832] 546 152	[5441] 615 152	[6634] 744 148	[6386] 724 144	[7222] 813 141	[7518] 849 141		
[14]	[497] 56 187	[1106] 125 187	[1730] 195 186	[2344] 265 186	[2972] 336 185	[3585] 405 184	[4213] 476 182	[4816] 544 180	[5430] 614 178	[6628] 736 174	[6351] 717 170	[7222] 813 166			
[16]	[472] 53 214	[1096] 124 214	[1715] 194 213	[2324] 263 212	[2947] 333 211	[3565] 403 210	[4203] 475 208	[4811] 544 206	[5420] 612 203	[6619] 746 199	[6351] 717 195	[7222] 813 191			
[18]	[437] 39 241	[1075] 121 241	[1690] 191 240	[2299] 260 239	[2917] 330 237	[3541] 400 236	[4188] 473 234	[4801] 542 231	[5400] 610 229	[6619] 746 224	[6362] 719 219				
[20]	[402] 45 268	[1055] 119 268	[1669] 189 268	[2274] 257 267	[2898] 327 266	[3521] 398 264	[4178] 472 261	[4791] 541 258	[5394] 609 255	[6581] 736 249					
[22]	[366] 41 296	[1005] 114 295	[1629] 184 295	[2257] 255 294	[2856] 323 292	[3480] 393 290	[4136] 467 288	[4756] 537 285	[5205] 588 279						
[25]	[301] 34 336	[940] 106 336	[1588] 179 335	[2231] 252 334	[2825] 319 333	[3419] 386 331	[4086] 462 328	[4710] 532 325	[5205] 588 314						
[30]		[845] 96 402	[1480] 167 401	[2151] 243 400	[2759] 312 398	[3328] 376 396	[3984] 450 392	[4573] 517 389	[5021] 567 377						
[35]			[1348] 152 468	[2057] 232 466	[2623] 296 464	[3183] 360 463	[3883] 439 457	[4354] 492 449							



# 4000 Series

## Performance Data

Motors run with high efficiency in all areas designated with a number for torque and speed. For best motor life select a motor to run with a torque and speed range shown in the light shaded area.

Performance data is typical at 120 SUS. Actual data may vary slightly from unit to unit in production.

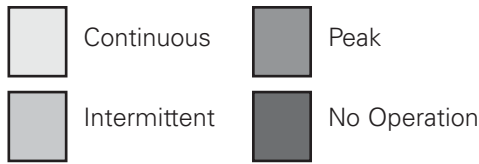

### 310cm<sup>3</sup>/r [19.0 in<sup>3</sup>/r] ΔPressure Bar [PSI]

	[250] 15	[500] 35	[750] 50	[1000] 70	[1250] 85	[1500] 105	[1750] 120	[2000] 140	[2250] 155	[2500] 170	[2750] 190	[3000] 205	[3250] 225	[3500] 240	[3750] 260
[5] 1.9	[600] 70 4	[1150] 130 2													
[1] 3.8	[620] 70 11	[1270] 145 11	[1920] 215 11	[2560] 290 10	[3170] 360 10	[3780] 425 10	[4290] 485 9	[4900] 555 9	[5490] 620 9	[6080] 685 8	[6670] 755 8	[7270] 820 7	[7880] 890 7	[8490] 960 6	[9080] 1025 5
[2] 7.5	[630] 70 23	[1280] 145 23	[1940] 220 22	[2590] 295 22	[3230] 365 21	[3830] 435 21	[4450] 505 20	[5070] 575 20	[5680] 640 19	[6300] 710 18	[6910] 780 18	[7530] 850 17	[8160] 920 17	[8790] 995 16	[9420] 1065 15
[4] 15	[640] 70 47	[1290] 145 47	[1960] 220 46	[2640] 300 46	[3290] 370 45	[3940] 445 45	[4600] 520 44	[5240] 590 44	[5880] 665 43	[6510] 735 42	[7150] 810 42	[7790] 880 41	[8450] 955 41	[9100] 1030 40	
[6] 23	[650] 75 71	[1300] 145 71	[1970] 225 70	[2660] 300 70	[3320] 375 69	[4000] 450 68	[4680] 530 67	[5330] 600 66	[5980] 675 66	[6630] 750 64	[7280] 825 64	[7940] 895 63			
[8] 30	[640] 70 96	[1300] 145 96	[1980] 225 95	[2670] 300 95	[3350] 380 94	[4030] 455 94	[4710] 530 93	[5360] 605 92	[6020] 680 91	[6670] 755 89	[7320] 825 88				
[10] 38	[620] 70 121	[1280] 145 120	[1970] 225 120	[2660] 300 119	[3340] 375 119	[4070] 460 118	[4740] 535 117	[5390] 610 116	[6050] 685 115	[6710] 760 112	[7370] 835 109				
[12] 45	[600] 70 145	[1260] 140 144	[1940] 220 144	[2630] 295 143	[3340] 375 142	[4040] 455 142	[4730] 535 141	[5390] 610 140	[6060] 685 139	[6720] 760 135					
[14] 53	[570] 65 169	[1240] 140 169	[1920] 215 168	[2600] 295 168	[3310] 375 167	[4000] 450 167	[4710] 530 165	[5380] 610 164	[6060] 685 163	[6730] 760 159					
[16] 61	[540] 60 193	[1230] 140 193	[1900] 215 192	[2580] 290 192	[3280] 370 190	[3970] 450 189	[4700] 530 188	[5380] 610 187	[6050] 685 185						
[18] 68	[490] 55 217	[1210] 135 217	[1880] 210 216	[2550] 290 216	[3240] 365 214	[3930] 445 213	[4680] 530 211	[5370] 605 209	[6040] 680 207						
[20] 76	[450] 50 242	[1190] 135 242	[1860] 210 242	[2520] 285 241	[3210] 365 240	[3900] 440 238	[4670] 530 236	[5360] 605 234	[6030] 680 232						
[22] 83	[420] 45 267	[1130] 130 266	[1820] 205 266	[2520] 285 265	[3180] 360 264	[3870] 440 262	[4640] 525 260	[5320] 600 258							
[25] 95	[340] 40 303	[1050] 120 303	[1780] 200 302	[2510] 285 301	[3160] 355 300	[3820] 430 299	[4590] 520 296	[5280] 595 293							
[30] 114		[1010] 115 363	[1700] 190 362	[2420] 275 360	[3100] 350 359	[3720] 420 358	[4500] 510 354	[5140] 580 351							
[35] 132			[1580] 180 422	[2360] 265 420	[2950] 335 419	[3540] 400 418	[4390] 495 413								

### 395cm<sup>3</sup>/r [24.0 in<sup>3</sup>/r] ΔPressure Bar [PSI]

	[250] 15	[500] 35	[750] 50	[1000] 70	[1250] 85	[1500] 105	[1750] 120	[2000] 140	[2250] 155	[2500] 170	[2750] 190	[3000] 205	[3250] 225	[3500] 240
[5] 1.9	[700] 80 4	[1340] 150 2												
[1] 3.8	[750] 85 9	[1430] 160 9	[2110] 240 8	[2770] 315 8	[3460] 390 8	[4170] 470 7	[4890] 550 7	[5610] 635 7	[6310] 715 5	[7010] 790 4	[7700] 870 2			
[2] 7.5	[800] 90 18	[1500] 170 18	[2290] 260 17	[3030] 340 16	[3850] 435 16	[4620] 520 15	[5310] 600 15	[6000] 680 14	[6750] 765 13	[7490] 845 13	[8240] 930 12	[8990] 1015 11	[9730] 1100 10	[10470] 1185 8
[4] 15	[860] 95 38	[1630] 185 38	[2470] 280 37	[3310] 375 36	[4120] 465 36	[4900] 555 35	[5640] 635 35	[6390] 720 34	[7190] 810 34	[7890] 890 33	[8780] 990 32			
[6] 23	[860] 95 57	[1690] 190 57	[2540] 285 56	[3410] 385 55	[4180] 470 54	[4980] 565 53	[5780] 655 52	[6580] 745 50	[7400] 835 49	[8220] 930 47				
[8] 30	[840] 95 76	[1680] 190 76	[2550] 290 75	[3400] 385 74	[4260] 480 73	[5090] 575 72	[5870] 665 70	[6650] 750 68	[7480] 845 66					
[10] 38	[800] 90 95	[1680] 190 95	[2550] 290 94	[3400] 385 93	[4260] 480 92	[5100] 575 91	[5920] 670 89	[6730] 760 86	[7560] 855 84					
[12] 45	[760] 85 114	[1660] 190 114	[2520] 285 113	[3380] 380 112	[4270] 480 111	[5110] 575 110	[5900] 665 108	[6690] 755 105						
[14] 53	[740] 85 133	[1640] 185 133	[2490] 280 132	[3370] 380 131	[4260] 480 130	[5100] 575 129	[5880] 665 127	[6650] 750 124						
[16] 61	[710] 80 153	[1620] 185 153	[2460] 280 152	[3350] 380 151	[4240] 480 149	[5080] 575 147	[5840] 660 145							
[18] 68	[680] 75 172	[1600] 180 172	[2430] 275 171	[3340] 375 170	[4220] 475 168	[5060] 570 166	[5810] 655 164							
[20] 76	[610] 70 192	[1580] 180 191	[2400] 270 190	[3320] 375 189	[4210] 475 187	[5040] 570 185	[5780] 655 183							
[22] 83	[570] 65 211	[1490] 170 210	[2340] 265 209	[3220] 365 208	[4160] 470 206	[5010] 565 204	[5740] 650 201							
[25] 95	[490] 55 239	[1350] 155 238	[2250] 255 237	[3080] 350 236	[4070] 460 235	[4960] 560 233	[5700] 645 230							
[30] 114		[1080] 120 285	[1650] 185 284	[2270] 255 282	[3020] 340 281	[3850] 435 279								
[35] 132			[1520] 170 331	[2120] 240 330	[2870] 325 328	[3760] 425 325								
[40] 151				[2050] 230 376	[2790] 315 374	[3620] 410 371								

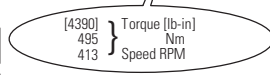

# 4000 Series

## Performance Data

Motors run with high efficiency in all areas designated with a number for torque and speed. For best motor life select a motor to run with a torque and speed range shown in the light shaded area.

Performance data is typical at 120 SUS. Actual data may vary slightly from unit to unit in production.

	Continuous		Peak
	Intermittent		No Operation

**495cm<sup>3</sup>/r [30.0 in<sup>3</sup>/r]**  
**ΔPressure Bar [PSI]**

[250]	[500]	[750]	[1000]	[1250]	[1500]	[1750]	[2000]	[2250]	[2500]
15	35	50	70	85	105	120	140	155	170

[.5]	[800]	[1750]								
1.9	90	200								
[1]	[880]	[1875]	[2875]	[3825]	[4775]	[5720]	[6670]	[7600]		
3.8	100	210	325	430	540	645	755	860		
[2]	[905]	[1940]	[2975]	[3990]	[5010]	[6010]	[7010]	[8000]	[8980]	
7.5	100	220	335	450	565	680	790	905	1015	
[4]	[935]	[2005]	[3075]	[4160]	[5245]	[6300]	[7355]	[8375]	[9400]	[10350]
15	105	225	345	470	595	710	830	945	1060	1170
[6]	[920]	[2010]	[3100]	[4185]	[5265]	[6345]	[7420]	[8445]	[9465]	
23	105	225	350	475	595	715	840	955	1070	
[8]	[905]	[2015]	[3125]	[4205]	[5290]	[6385]	[7485]	[8510]		
30	100	230	355	475	600	720	845	960		
[10]	[880]	[1995]	[3095]	[4205]	[5295]	[6390]	[7480]	[8455]	[9460]	
38	100	225	350	475	600	720	845	960		
[12]	[860]	[1975]	[3095]	[4200]	[5305]	[6390]	[7475]	[8455]		
45	95	225	350	475	600	720	845			
[14]	[830]	[1945]	[3055]	[4165]	[5275]	[6360]	[7445]	[8405]		
53	106	220	345	470	595	720	840			
[16]	[805]	[1910]	[3020]	[4130]	[5245]	[6330]	[7420]			
61	90	215	340	465	595	715	840			
[18]	[740]	[1860]	[2980]	[4105]	[5235]	[6305]	[7380]			
68	85	210	335	465	590	715	835			
[20]	[680]	[1810]	[2940]	[4085]	[5225]	[6285]				
76	75	205	330	460	590	710				
[25]	[570]	[1665]	[2800]	[4005]	[5210]	[6135]				
95	65	190	315	455	590	695				
[30]		[1520]	[2645]	[3765]	[4885]	[5985]				
114		170	300	425	550	675				
[35]			[2400]	[3510]						
132			270	395						
[40]			[2155]	[3260]						
151			245	370						

[2850] } Torque [lb-in]  
320 } Nm  
241 } Speed RPM

**625cm<sup>3</sup>/r [38.0 in<sup>3</sup>/r]**  
**ΔPressure Bar [PSI]**

[250]	[500]	[750]	[1000]	[1250]	[1500]	[1600]	[1700]	[1800]	[2000]
15	35	50	70	85	105	100	115	125	140

[.5]	[1000]									
1.9	115									
[1]	[1080]	[2340]	[3600]	[4850]	[6100]	[7350]	[8290]	[8760]		
3.8	120	265	405	550	690	830	885	935	990	
[2]	[1085]	[2380]	[3675]	[5010]	[6350]	[7625]	[8115]	[8605]	[9095]	[10075]
7.5	125	270	415	565	715	860	915	970	1030	1140
[4]	[1090]	[2420]	[3750]	[5175]	[6600]	[7900]	[8410]	[9000]	[9590]	[10450]
15	125	275	425	585	745	895	950	1015	1085	1180
[6]	[1095]	[2460]	[3825]	[5220]	[6620]	[7950]	[8430]	[8910]	[9490]	
23	125	280	430	590	750	900	950	1005	1070	
[8]	[1100]	[2500]	[3900]	[5270]	[6640]	[7990]	[8460]	[8925]		
30	125	280	440	595	750	905	955	1010		
[10]	[1130]	[2550]	[3975]	[5320]	[6670]	[8045]	[8595]	[9150]		
38	130	290	450	600	755	910	970	1035		
[12]	[1160]	[2600]	[4050]	[5375]	[6700]	[8100]	[8660]			
45	130	295	460	605	760	915	980			
[14]	[1105]	[2535]	[3965]	[5325]	[6685]	[8065]	[8620]			
53	125	285	450	600	755	910	975			
[16]	[1050]	[2465]	[3880]	[5275]	[6670]	[8035]	[8580]			
61	120	280	440	595	755	910	970			
[18]	[990]	[2405]	[3825]	[5240]	[6655]	[8045]	[8585]			
68	110	270	430	590	750	900	960			
[20]	[930]	[2350]	[3770]	[5205]	[6640]					
76	105	265	425	590	750					
[25]	[750]	[2175]	[3600]	[5000]	[6400]					
95	85	245	405	565	725					
[30]	[550]	[1975]	[3400]	[4800]	[6200]					
114	60	225	385	530	700					
[35]			[3125]	[4545]						
132			355	515						
[40]			[2850]	[4295]						
151			320	485						



# 4000 Series

## Dimensions

Standard Mount

## Ports

- 1 1/16 -12 UN-2B SAE O-ring Staggered Ports (2)
- 7/16 -20 UNF-2B SAE O-ring Case Drain Port (1) or
- 4 Bolt 3/4 inch Split Flange Ports (2)
- 7/16 -20 UNF-2B SAE O-ring Case Drain Port (1) or
- G 3/4 (BSP) Staggered Ports (2)
- G 1/4 (BSP) Case Drain Port (1)

## Standard Rotation Viewed from Shaft End

- Port A Pressurized — CW
- Port B Pressurized — CCW

## Standard Mount

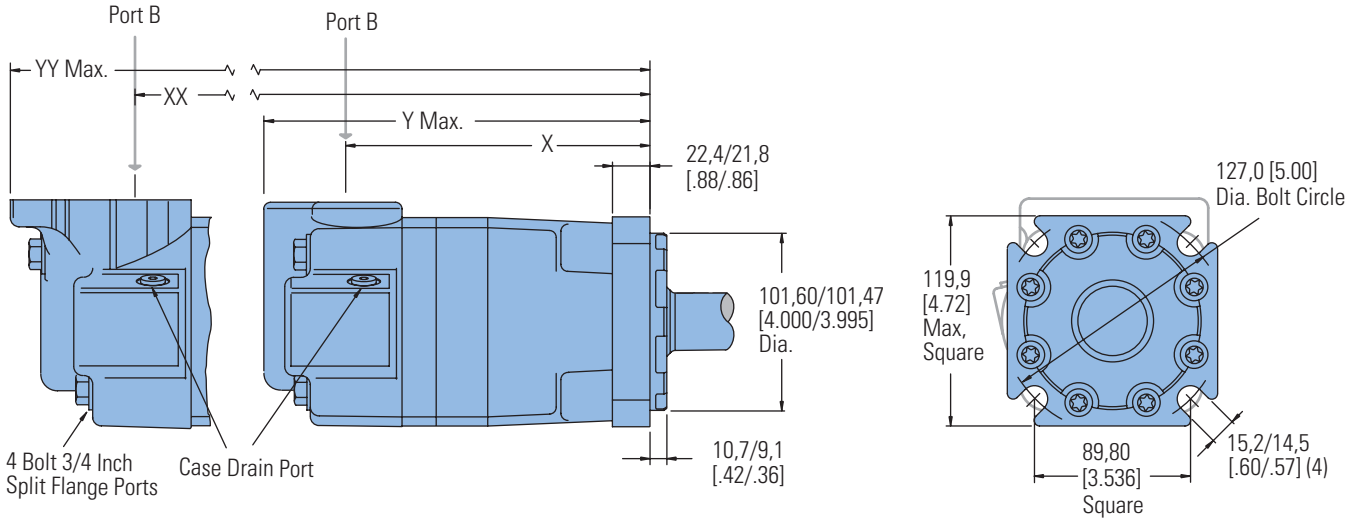

## SAE C Flange

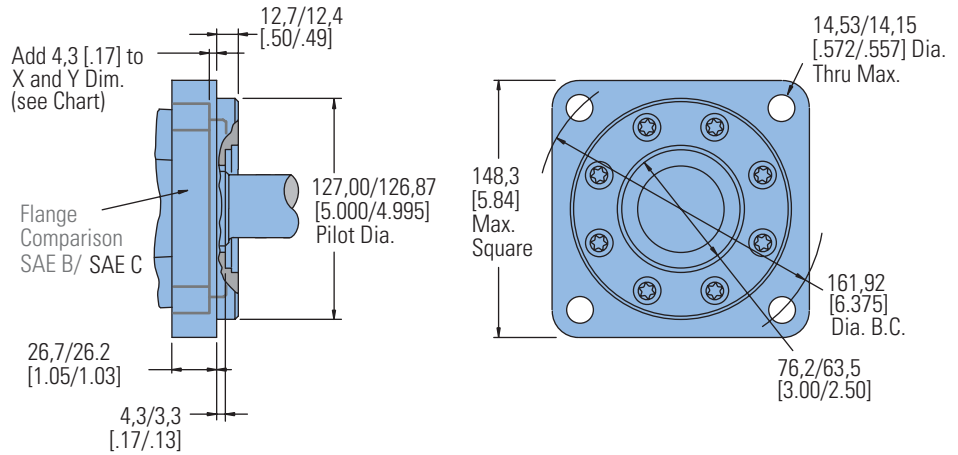

## STANDARD MOUNT MOTOR DIMENSIONS

Displacement cm <sup>3</sup> /r [in <sup>3</sup> /r]	X mm [inch]	Y mm [inch]	XX mm [inch]	YY mm [inch]
110 [6.7]	158,3 [6.23]	214,4 [8.44]	167,3 [6.59]	246,3 [9.70]
130 [7.9]	162,3 [6.39]	218,4 [8.60]	171,3 [6.75]	250,4 [9.86]
160 [9.9]	168,7 [6.64]	224,7 [8.85]	177,7 [7.00]	256,7 [10.11]
205 [12.5]	177,2 [6.98]	233,2 [9.18]	186,2 [7.33]	265,2 [10.44]
245 [15.0]	168,7 [6.64]	224,7 [8.85]	177,7 [7.00]	256,7 [10.11]
310 [19.0]	177,2 [6.98]	233,2 [9.18]	186,2 [7.33]	265,2 [10.44]
395 [24.0]	187,9 [7.40]	243,9 [9.60]	196,9 [7.75]	275,9 [10.86]
495 [30.0]	200,7 [7.90]	256,8 [10.11]	209,7 [8.26]	288,8 [11.37]
625 [38.0]	217,8 [8.58]	273,9 [10.78]	226,7 [8.93]	305,9 [12.04]

# 4000 Series

Dimensions

Wheel Mount

## Wheel Mount

### Ports

- 1 1/16 -12 UN-2B SAE O-ring Staggered Ports (2)
- 7/16 -20 UNF-2B SAE O-ring Case Drain Port (1) or
- 4 Bolt 3/4 inch Split Flange Ports (2)
- 7/16 -20 UNF-2B SAE O-ring Case Drain Port (1) or
- G 3/4 (BSP) Staggered Ports (2)
- G 1/4 (BSP) Case Drain Port (1)

### Standard Rotation Viewed from Shaft End

- Port A Pressurized — CW
- Port B Pressurized — CCW

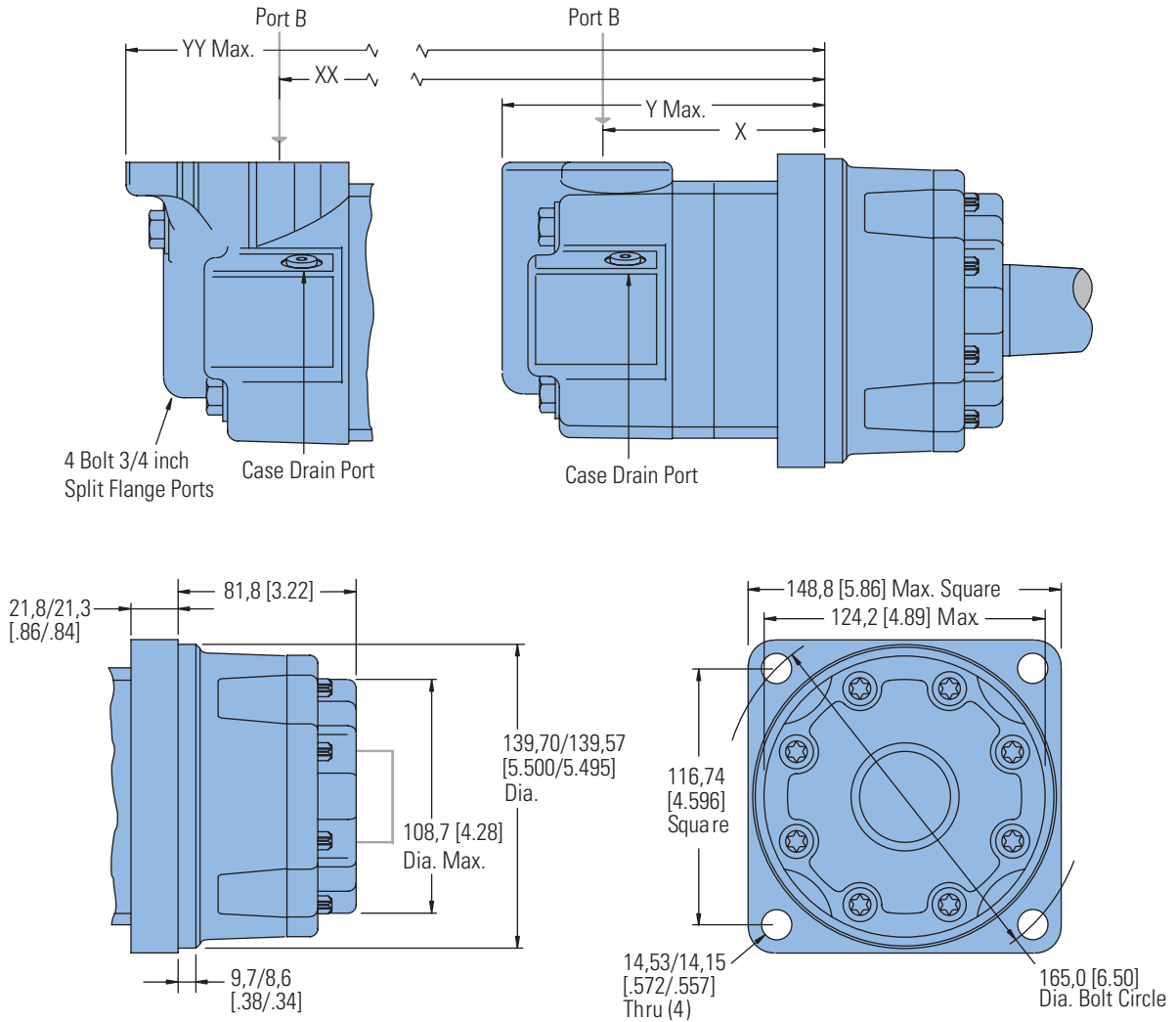

### WHEEL MOUNT MOTOR DIMENSIONS

Displacement cm <sup>3</sup> /r [in <sup>3</sup> /r]	X mm [inch]	Y mm [inch]	XX mm [inch]	YY mm [inch]
110 [ 6.7]	87,5 [3.45]	143,3 [5.64]	96,4 [3.80]	175,3 [6.90]
130 [ 7.9]	91,6 [3.61]	147,3 [5.80]	100,5 [3.96]	179,3 [7.06]
160 [ 9.9]	97,8 [3.85]	153,7 [6.05]	106,8 [4.21]	185,7 [7.31]
205 [12.5]	106,4 [4.19]	162,3 [6.39]	115,4 [4.55]	194,3 [7.65]
245 [15.0]	97,8 [3.85]	153,7 [6.05]	106,8 [4.21]	185,7 [7.31]
310 [19.0]	106,4 [4.19]	162,3 [6.39]	115,4 [4.55]	194,3 [7.65]
395 [24.0]	117,1 [4.61]	173,0 [6.81]	126,1 [4.97]	205,0 [8.07]
495 [30.0]	129,9 [5.12]	185,7 [7.31]	138,8 [5.47]	217,7 [8.57]
625 [38.0]	146,9 [5.79]	202,9 [7.99]	156,0 [6.14]	235,0 [9.25]

# 4000 Series

Dimensions

Bearingless

## Ports

- 1 1/16 -12 UN-2B SAE O-ring Staggered Ports (2)
- 7/16 -20 UNF-2B SAE O-ring Case Drain Port (1) or
- 4 Bolt 3/4 inch Split Flange Ports (2)
- 7/16 -20 UNF-2B SAE O-ring Case Drain Port (1) or
- G 3/4 (BSP) Staggered Ports (2)
- G 1/4 (BSP) Case Drain Port (1)

## Standard Rotation Viewed from Shaft End

- Port A Pressurized — CW
- Port B Pressurized — CCW

## Bearingless

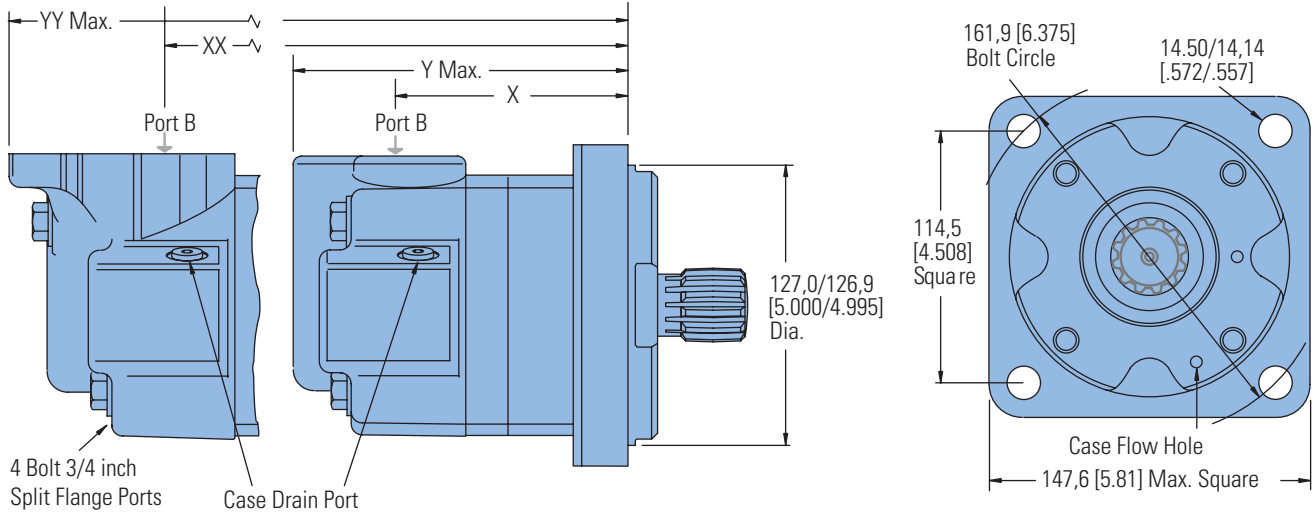

For 4000 Series Bearingless Motor application information contact your Eaton representative (mating coupling blanks available from Eaton Hydraulics).

### Note:

After machining blank, part must be hardened per Eaton specification.

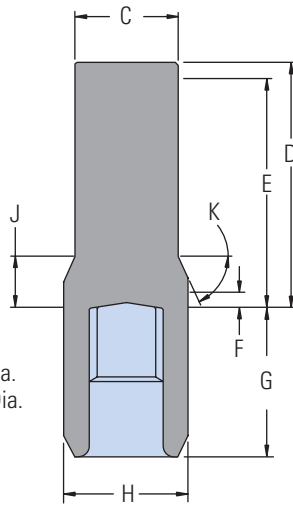

- C 47,2 [1.86] Dia.
- D 112,5 [4.43] Max.
- E 107,4 [4.23] Full Form Dia.
- F 7,4 [.29] Min. Full Form Dia.
- G 68,8 [2.71] Max.
- H 56,9 [2.24] Dia.
- J 18,29 [.720]
- K 38°

Mating Coupling Blank  
Eaton Part No. 12745-003

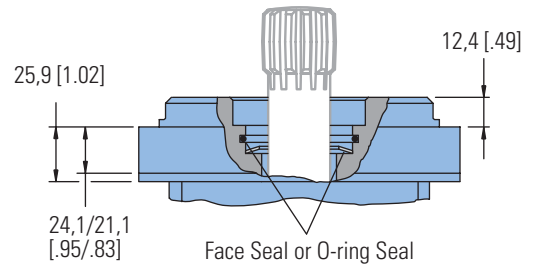
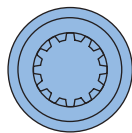

## BEARINGLESS MOTOR DIMENSIONS

Displacement cm <sup>3</sup> /r [in <sup>3</sup> /r]	X mm [inch]	Y mm [inch]	XX mm [inch]	YY mm [inch]
110 [6.7]	91,0 [3.58]	146,8 [5.78]	100,1 [3.94]	178,8 [7.04]
130 [7.9]	95,0 [3.74]	150,8 [5.94]	104,1 [4.10]	182,9 [7.20]
160 [9.9]	101,4 [4.00]	157,1 [6.19]	110,5 [4.35]	189,2 [7.45]
205 [12.5]	109,9 [4.33]	165,7 [6.52]	118,9 [4.68]	197,6 [7.78]
245 [15.0]	101,4 [4.00]	157,1 [6.19]	110,5 [4.35]	189,2 [7.45]
310 [19.0]	109,9 [4.33]	165,7 [6.52]	118,9 [4.68]	197,6 [7.78]
395 [24.0]	120,6 [4.75]	176,3 [6.94]	129,5 [5.10]	208,3 [8.20]
495 [30.0]	133,5 [5.26]	189,2 [7.45]	142,5 [5.61]	221,2 [8.71]
625 [38.0]	150,5 [5.93]	206,3 [8.12]	159,5 [6.28]	238,3 [9.38]

# 4000 Series

## Installation Information

### Bearingless

- 1 Internal spline in mating part to be as follows: Material to be ASTM A304, 8620H. Carbonize to a hardness of 60-64 HRc with case depth (to 50HRc) of 0,076 - 1,27 [.030 - .050] (dimensions apply after heat treat).
- 2 Mating part to have critical dimensions as shown. Oil holes must be provided and open for proper oil circulation.
- 3 Seal to be furnished with motor for proper oil circulation thru splines.
- 4 Some means of maintaining clearance between shaft and mounting flange must be provided.
- 5 Counterbore designed to adapt to a standard sleeve bearing 50,010 - 50,040 [1.9689 - 1.9700] ID by 60,050 - 60,080 [2.3642 - 2.3653] (Oilite bronze sleeve bearing).
- 6 Similar to SAE "C" Four Bolt Flange.
- 7 52,8 [2.08] Max. dimension to be maintained when assembling shipping and installing unit to insure valve drive engagement with valve (this is required on displacement code number 24 only).

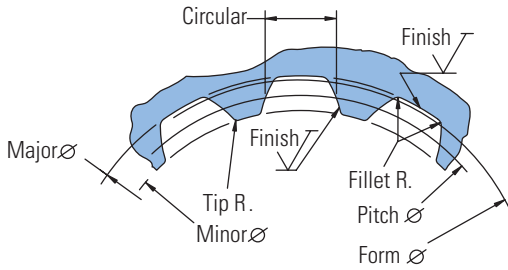
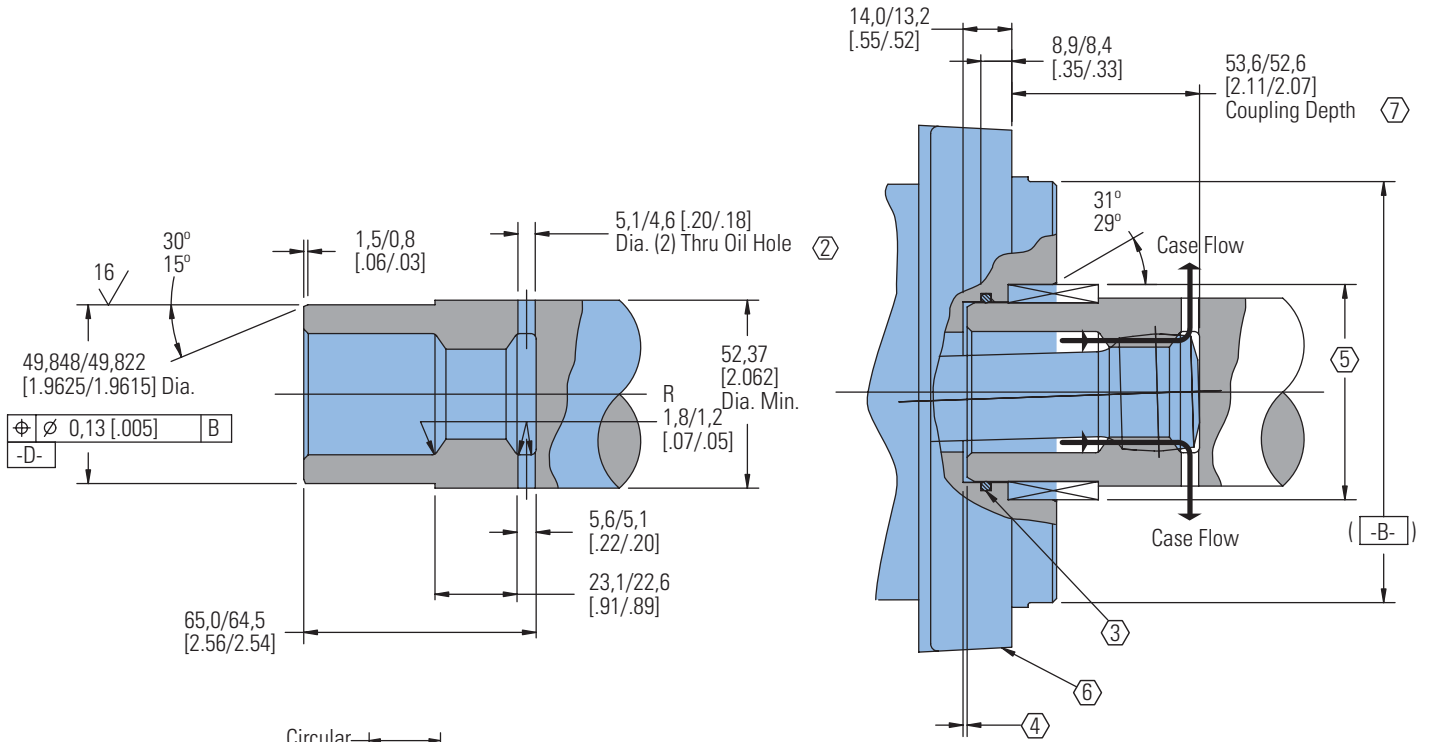

Spline Pitch.....	10/20
Pressure Angle.....	30°
Number of teeth.....	12
Class of Fit.....	Ref. 5
Type of Fit.....	Side
Pitch Diameter.....	Ref. 30,480000 [1.2000000] $\begin{matrix} \nearrow \\ \searrow \end{matrix}$ 0,20 [.008]   D
Base Diameter.....	Ref. 26,396455 [1.0392305]
Major Diameter.....	33,43 [1.316] Max. 33,23 [1.308] Min.
Min. Minor Diameter.....	28,40 - 28,58 [1.118 - 1.125]
Form Diameter, Min.....	32,59 [1.283]
Fillet Radius.....	0,63 - 0,76 [.025 - .030]
Tip Radius.....	0,26 - 0,51 [.010 - .020]
Finish.....	1,6 (63)
Involute Profile Variation.....	+0,000 -0,025 [+ .0000 - .0010]
Total Index Variation.....	0,038 [.0015]
Lead Variation.....	0,013 [.0005]
<b>Circular Space Width:</b>	
Maximum Actual.....	5,045 [1.986]
Minimum Effective.....	4,995 [1.951]
Maximum Effective.....	Ref. 5,009 [1.972]
Minimum Actual.....	Ref. 4,986 [1.963]
Dimension Between Two Pins.....	Ref. 22,783 - 22,929 [.8970 - .9027]
Pin Diameter.....	5,334 [.2100] Pins to Have 3,73 [.147]
Wide Flat for Root Clearance	

C-4

# 4000 Series

## Dimensions

### Shafts

### 1 1/4 Inch Straight

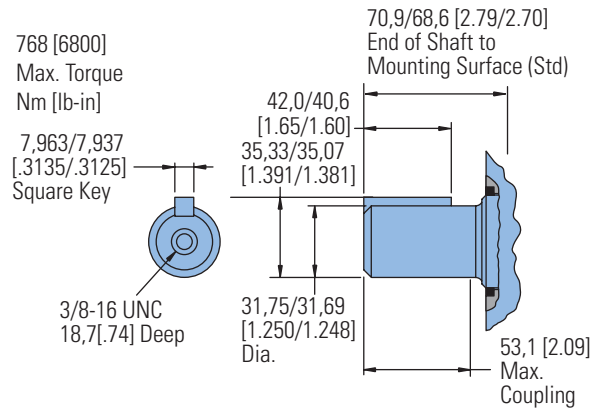

### 1 1/4 -14 Tooth Splined

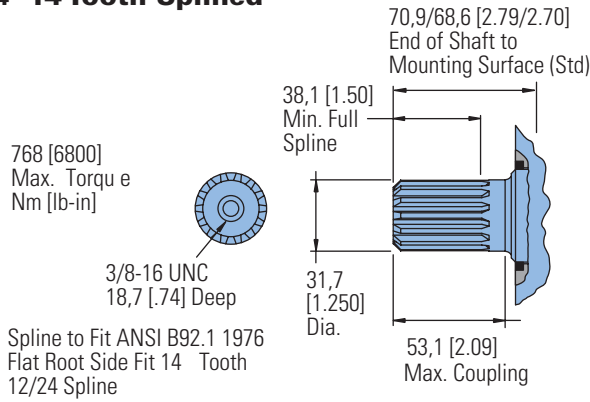

### 1 5/8 Tapered

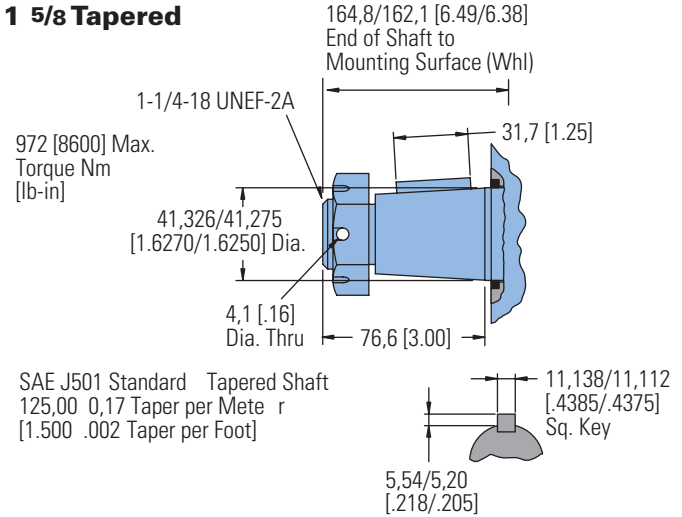

### 40 mm Straight

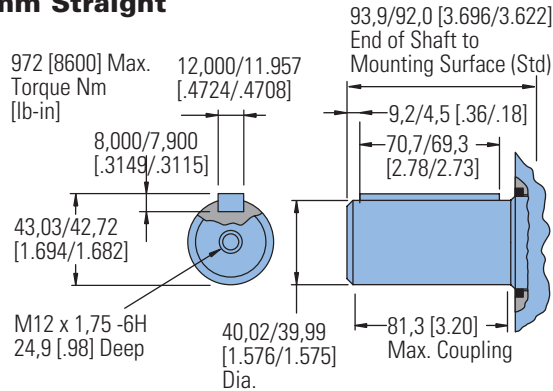

### Tapered Shaft Hub Data

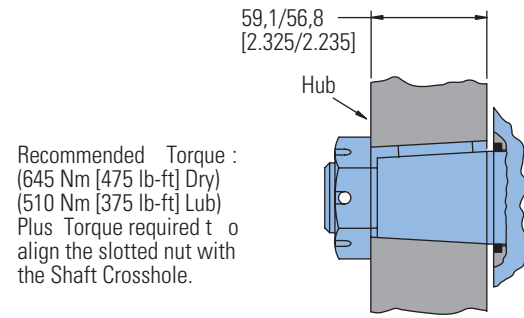

### 1 1/2 Inch 17-Tooth Splined

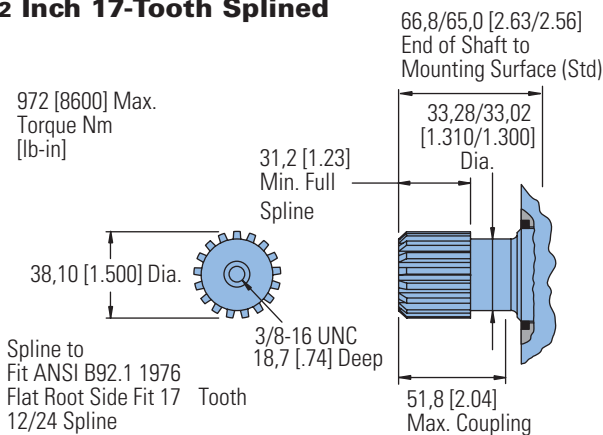

### Slotted Hexagon Nut

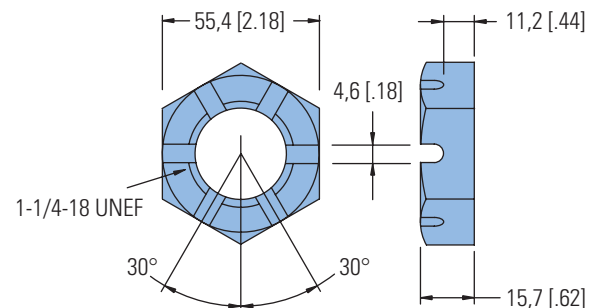

# 4000 Series

## Shaft Side Load Capacity

These curves indicate the radial load capacity on the motor shaft(s) at various locations with an allowable external thrust load of 454 kg [1000 lb].

**Note:**

Case pressure will increase the allowable Inward thrust load and decrease the allowable outward thrust load. Case pressure will push outward on the shaft at 94 kg/7 Bar [208 lb/100 PSI].

**Each curve is based on**

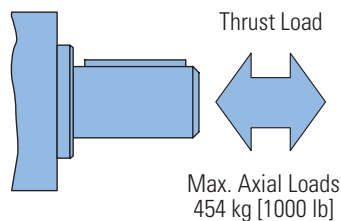

**B 10 bearing life (2000 hours of 12,000,000 shaft revolutions at 100 RPM) at rated output torque.**

To determine radial load at speeds other than 100 RPM, multiply the load values given on the bearing curve by the factors in the chart below.

RPM	Multiplication Factor
50	1.23
100	1.00
200	0.81
300	0.72
400	0.66
500	0.62
600	0.58
700	0.56
800	0.54

For 3,000,000 shaft revolutions or 500 hours—Increase these shaft loads 52%.

Standard Motor  
Straight and Splined Shafts

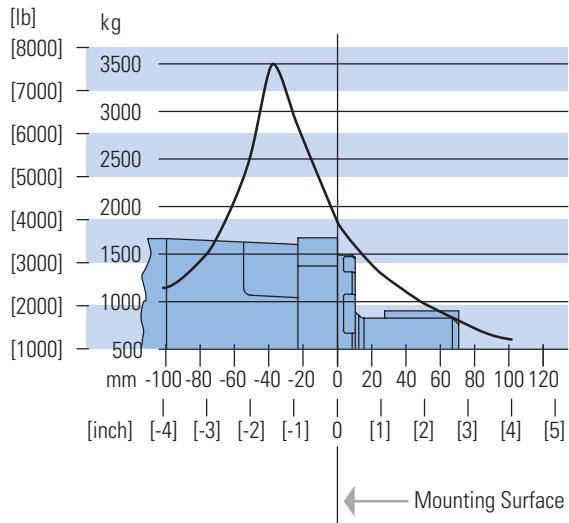

Wheel Motor Tapered Shaft

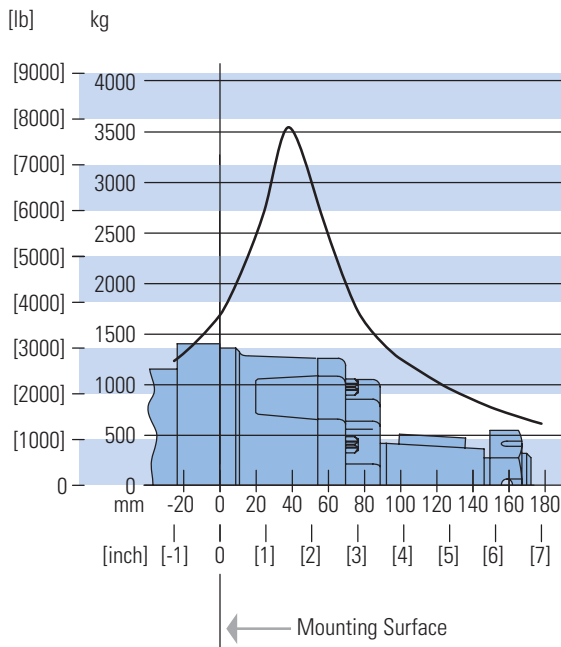

# 4000 Series

## Case Pressure and Case Port

Char-Lynn 4000 Series motors are durable and have long life as long as the recommended case pressure is not exceeded. Allowable case pressure is highest at low shaft speeds. Consequently, motor life will be shortened if case pressure exceeds these ratings (acceptability may vary with application). Determine if an external case drain is required from the case pressure seal limitation chart.

### Case Porting Advantage

**Contamination Control** — flushing the motor case.

**Cooler Motor** — exiting oil draws motor heat away.

**Extend Motor Seal Life** — maintain low case pressure with a preset restriction in the case drain line.

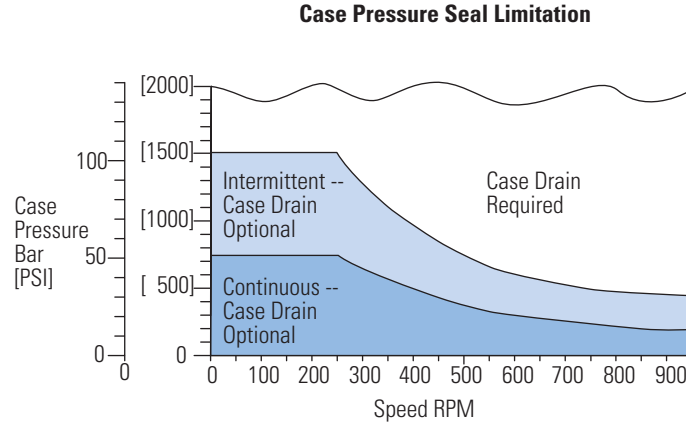

# 4000 Series

## Dimensions

### Ports

#### 1-1/16-12 O-ring Ports (2) or G 3/4 (BSP) Ports (2)

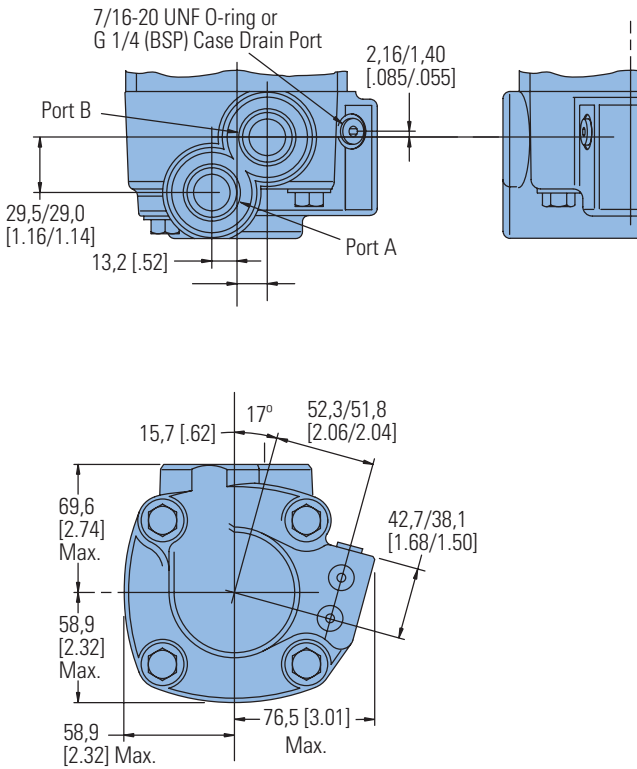

#### 4 Bolt 3/4 Inch Split Flange Ports to Fit SAE J518 c (2)

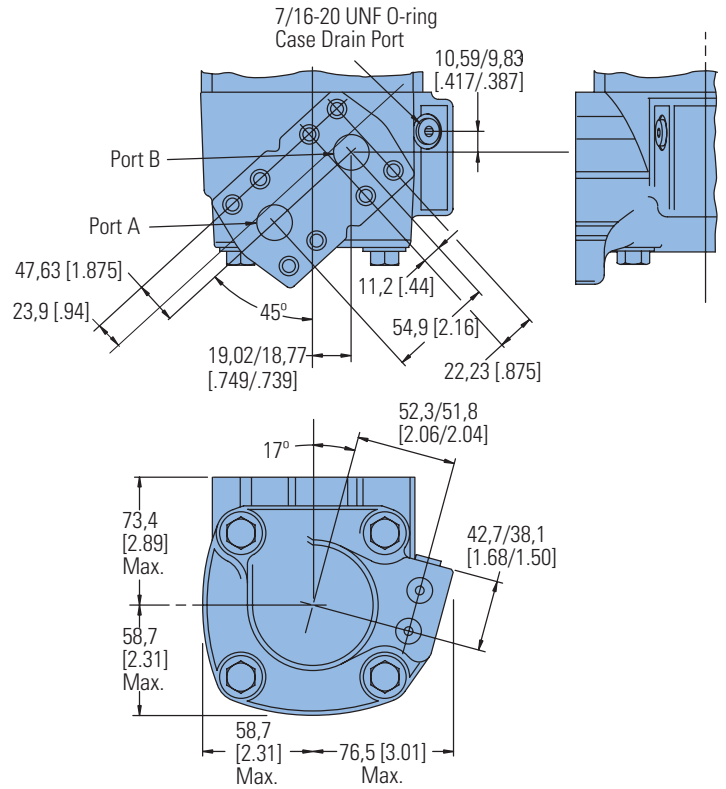

#### 7/8-14 O-ring Ports (2) or M22 x 1,5-6H Ports (2)

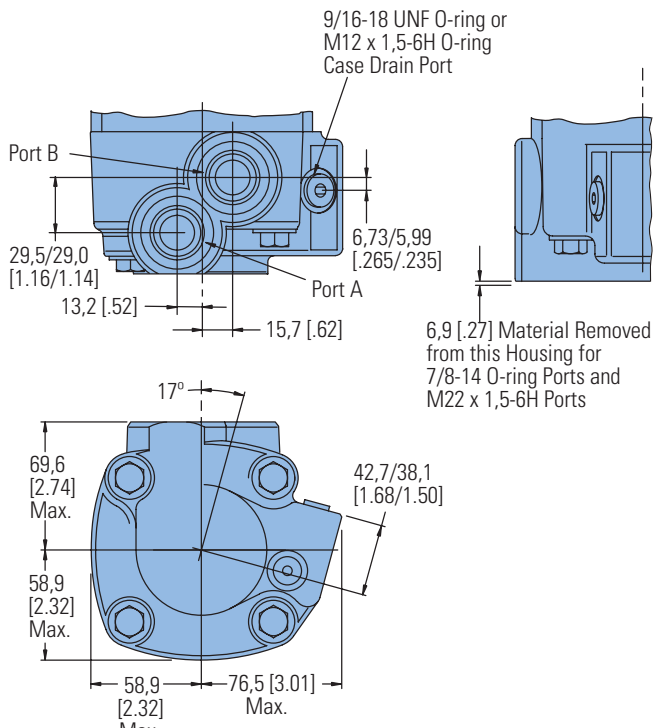



# 4000 Series

## Product Numbers

### Note:

For 4000 Series Motors with a configuration **Not Shown** in the charts below: Use model code number system on the next page to specify product in detail.

Use digit prefix —109-, 110-, or 111- plus four digit number from charts for complete product number— Example 111-1057.

**Orders will not be accepted without three digit prefix.**

MOUNTING		SHAFT	PORT SIZEDISPL. cm <sup>3</sup> /r [in <sup>3</sup> /r] / PRODUCT NUMBER									
			110 [ 6.7]	130 [ 7.9]	160 [ 9.9]	205 [12.5]	245 [15.0]	280* [17.1]	310 [19.0]	395 [24.0]	495 [30.0]	625 [38.0]
Standard SAE B-Mount	1 1/4 Inch Straight	1 1/16 O-ring	109-1100	-1101	-1102	-1103	-1104	-1094	-1105	-1106	-1212	-1215
		3/4 inch Split Flange	109-1001	-1054	-1002	-1003	-1055	—	-1056	-1057	—	—
	1 5/8 Inch Tapered	1 1/16 O-ring	109-1107	-1108	-1109	-1110	-1111	—	-1112	-1113	-1479	-1455
		3/4 inch Split Flange	109-1006	-1058	-1007	-1008	-1059	—	-1402	-1061	—	—
	1 1/4 Inch 14 T Splined	1 1/16 O-ring	109-1114	-1115	-1116	-1117	-1118	—	-1119	-1120	—	—
		3/4 inch Split Flange	109-1011	-1062	-1012	-1013	-1063	—	-1064	-1065	—	—
Standard SAE C-Mount	40 mm Straight	G 3/4 (BSP)	109-1184	-1185	-1227	-1224	-1225	—	-1189	-1190	—	—
	1 1/4 Inch 17 T Splined	G 3/4 (BSP)	109-1191	-1192	-1193	-1194	-1195	—	-1196	-1197	—	—
Wheel Motor	1 1/4 Inch Straight	1 1/16 O-ring	110-1074	-1075	-1076	-1077	-1078	—	-1079	-1080	—	-1122
		3/4 inch Split Flange	110-1001	-1040	-1002	-1003	-1041	—	-1042	-1043	—	—
	40 mm Straight	G 3/4 (BSP)	110-1108	-1109	-1110	-1111	-1112	—	-1113	-1125	—	—
	1 5/8 Inch Tapered	1 1/16 O-ring	110-1081	-1082	-1083	-1084	-1085	—	-1086	-1087	1116	-1117
		3/4 inch Split Flange	110-1006	-1044	-1007	-1008	-1045	—	-1046	-1047	—	—
	1 1/4 Inch 14 T Splined	1 1/16 O-ring	110-1088	-1089	-1090	-1091	-1092	—	-1093	-1094	—	—
3/4 inch Split Flange		110-1011	-1048	-1012	-1013	-1049	—	-1050	-1051	—	—	
Bearingless		1 1/16 O-ring	111-1033	-1034	-1035	-1036	-1037	—	-1038	-1039	-1062	-1063
		3/4 inch Split Flange	111-1044	-1015	-1045	-1046	-1016	—	-1017	-1018	—	—
		G 3/4 (BSP)	111-1052	-1053	-1054	-1055	-1056	—	-1057	-1058	—	—

\* New Release

111-1057

# 4000 Series

## Model Code

The following 30-digit coding system has been developed to identify all of the configuration options for the 4000 Series motor. Use this model code to specify a motor with the desired features. All 30 digits of the code must be present when ordering. You may want to photocopy the matrix below to ensure that each number is entered in the correct box.

M	0	4	***	**	**	**	**	*	**	*	*	**	**	**	**	**	**	*											
1	2	3	4	5	6	7	8	9	10	11	12	13	14	15	16	17	18	19	20	21	22	23	24	25	26	27	28	29	30

**1** Product  
M - Motor

**2**, **3** Series  
04 - 4000 Series

**4**, **5**, **6** Displacement  
cm<sup>3</sup>/r [in<sup>3</sup>/r]  
067 - 109.8 cm<sup>3</sup>/r [6.70 in<sup>3</sup>/r]  
080 - 130.3 cm<sup>3</sup>/r [7.95 in<sup>3</sup>/r]  
099 - 162.2 cm<sup>3</sup>/r [9.90 in<sup>3</sup>/r]  
125 - 205.5 cm<sup>3</sup>/r [12.54 in<sup>3</sup>/r]  
150 - 246.3 cm<sup>3</sup>/r [15.03 in<sup>3</sup>/r]  
171 - 280.1 cm<sup>3</sup>/r [17.09 in<sup>3</sup>/r]  
190 - 311.8 cm<sup>3</sup>/r [19.03 in<sup>3</sup>/r]  
225 - 369.0 cm<sup>3</sup>/r [22.52 in<sup>3</sup>/r]  
240 - 393.9 cm<sup>3</sup>/r [24.04 in<sup>3</sup>/r]  
301 - 492.6 cm<sup>3</sup>/r [30.06 in<sup>3</sup>/r]  
342 - 560.2 cm<sup>3</sup>/r [34.18 in<sup>3</sup>/r]  
381 - 623.9 cm<sup>3</sup>/r [38.07 in<sup>3</sup>/r]

**7**, **8** Mounting Type  
AA - Bearingless, 4 Bolt: 127.00 [5.000] Pilot Dia. 14.27 [.562] Dia. Holes on 161.92 [6.375] Dia. Bolt Circle  
AB - Standard, 4 Bolt: 101.60 [4.000] Pilot Dia. 14.7 [.58] Slots on 127.00 [5.000] Dia. Bolt Circle. (SAE B)  
AC - Wheel, 4 Bolt: 139.70 [5.500] Pilot Dia. 14.27 [.562] Dia. Holes on 165.10 [6.500] Dia. Bolt Circle.  
AD - Wheel, 4 Bolt: 127.00 [5.000] Pilot Dia. .500-13 UNC-2B Threaded Holes on 147.62 [5.812] Dia. Bolt circle.  
AF - Standard, 4 Bolt: 127.00 [5.000] Pilot Dia. 14.27 [.562] Dia. Holes on 161.92 [6.375] Dia. Bolt Circle. (SAE C)  
AH - Standard: ISO Flange 125 B4hw (ISO 3019/2) 124.97 [4.920] Pilot Dia. 14.27 [.562] Dia. Holes on 160.00 [6.299] Dia. Bolt Circle

AP - Wheel, 4 Bolt: 160.0 [6.30] Pilot Dia. with 5.8 [.23] Pilot Length and 18.00 [.709] Dia Holes on 200.00 [7.874] Bolt Circle (ISO Compatible)

**9**, **10** Output Shaft  
00 - None (Bearingless)  
01 - 31.75 [1.250] Dia. Straight With .375-16UNC-2B Thread, 53.1 [2.09] Max Coupling Length, 7.938 [.3125] Sq x 41.27 [1.625] Straight Key  
02 - 41.28 [1.625] Dia. Tapered with 11.112 [.4375] Sq x 31.75 [1.250] Straight Key, 1.250-18UNEF-2A Thread with Slotted Hex Nut  
03 - 31.75 [1.250] Dia. Flat Root Side Fit, 14 Tooth, 12/24 DP 30° Involute Spline, 38.1 [1.50] Minimum Full Spline Length with .375-16UNC-2B Thread

10 - 38.10 [1.500] Dia. Flat Root Side Fit, 17 Tooth, 12/24 DP 30°. Involute Spline, 31.2 [1.23] Minimum Full Spline Length, with .375-16 UNC-2B Thread in End  
11 - 40.00 [1.575] Dia. Straight with M12 x 1.75-6H Thread, 7.955 [.3132] x 11.979 [.4716] Wide X 69.98 [2.755] Straight Key  
21 - 40.00 [1.575] Dia. 10:1 Tapered Shaft per ISO R775 with .750-16 UNF-2B Threaded in End, 12W x 8H 70L [.472W x .313H x 2.76L] Key  
22 - None (Bearingless) European Spline  
25 - 42.00 [1.654] Dia. 10:1 Tapered Shaft per ISO R775 with .750-16 UNF-2B Thread in End, 12W x 8H X 63L [.472W X .313H X 2.48L] Key

**11**, **12** Ports  
AA - .875-14 UNF-2B SAE O-Ring Ports - Staggered Ports  
AB - 1.0625-12 UN-2B SAE O-Ring Ports - Staggered Ports  
AC - G 3/4 Ports - Staggered Ports  
AD - 19.05 [.750] 4 Bolt Split Flange Staggered Ports Standard Pressure Series (Code 61)  
AE - M22 X 1.5-6H O-Ring Port - Staggered Ports  
AG - 12.70 [.500] Dia. Manifold Ports  
AJ - Dash 12 Stc Type II+ (Snap to Connect) Ports - Staggered Ports

**13**, **14** Case Flow Options  
00 - None  
01 - .5625-18 UNF-2B SAE O-Ring Port with Shuttle  
02 - .4375-20 UNF-2B SAE O-ring Port with Check Valve  
03 - G 1/4 BSP Straight Thread with Check Valve  
06 - .4375-20 UNF-2B SAE O-ring Port with Reverse Flow Shuttle  
10 - Dash 6 Stc Type II + (Snap to Connect) Port

**15** Low Pressure Relief  
0 - None  
A - Set at 4.5 Bar [65 lbf/in<sup>2</sup>]  
B - Set at 15.2 Bar [220 lbf/in<sup>2</sup>]

**16**, **17** Pressure/Flow Option  
00 - None

**18** Geroler Option  
0 - Standard

**19** Seal Option  
00 - Standard Seals  
02 - Seal Guard  
03 - Viton Seals  
04 - Viton Shaft Seal  
11 - High pressure shaft seal, slinger seal  
19 - Extreme duty seal guard

**20**, **21** Accessories  
00 - None  
AC - M 12 Threaded Connector, Long Body Digital Speed and Direction Pickup (Two 36 Pulse Signals in Quadrature per Revolution Pin 1=Power Supply, Pin 2=Output Signal 1, Pin 3=Common, Pin 4=Output Signal 2)  
AD - M 12 Threaded Connector, Digital Speed And Direction Pickup (One 72 Pulse per Rev Speed Signal and One Directional Signal (Pin 1=Power, Pin 2=Direction, Pin 2=Common, Pin 4=Speed)

**22**, **23** Special Features (Hardware)  
00 - None  
17 - Low Noise Valve Plate

**24**, **25** Special Features (Assembly)  
00 - None

**26**, **27** Paint/Packaging  
00 - No Paint, Individual Box  
AA - Low Gloss Black Primer, Individual Box  
AB - Epoxy Coated (Frost Gray), Individual Box

**28**, **29** Customer Identification  
00 - None

**30** Design Code  
F - Sixth

Feature in **bold** are preferred and allow for shorter lead time.



# 6000 Series

## Highlights

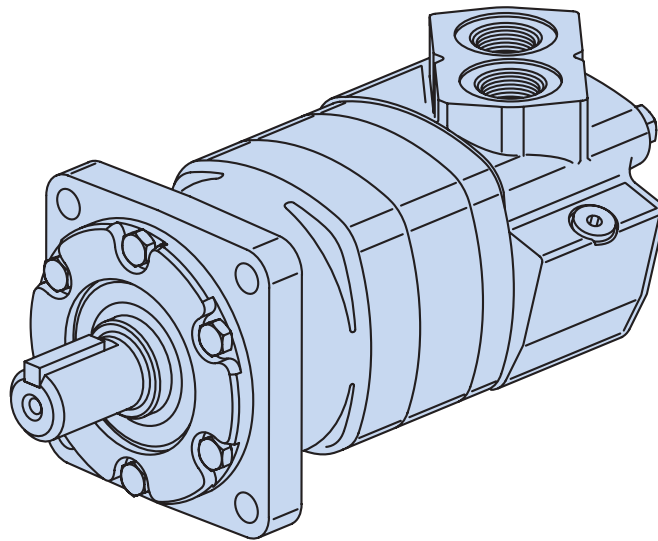

### Features

- 9 displacements available
- Presents a multitude of options that make this motor very “smart” and flexible to apply

### Benefits

- Very tough motor for demanding applications
- Can be used in a multitude of industries
- Very easy/flexible to integrate in a system

### Applications

- Mobile equipment
- Snow Removal, mowing
- Spayer, trencher
- Wood products

### Description

With torque up to 15,000 in-lb and 40 gpm continuous, this motor is packed with power operates very smoothly.

### Specifications

Geroler Element	9 Displacements
Flow l/min [GPM]	150 [40] Continuous** 225 [60] Intermittent*
Speed RPM	775 Cont.** 866 Inter.*
Pressure bar [PSI]	200 [3000] Cont.** 300 [4500] Inter.*
Torque Nm [lb-in]	1685 [14920] Cont.** 1875 [16580] Inter.*

\*\* Continuous — (Cont.) Continuous rating, motor may be run continuously at these ratings.

\* Intermittent — (Inter.) Intermittent operation, 10% of every minute.

C-5



Mowing



Snow Removal



Sprayer



Trencher

# 6000 Series

## Specifications

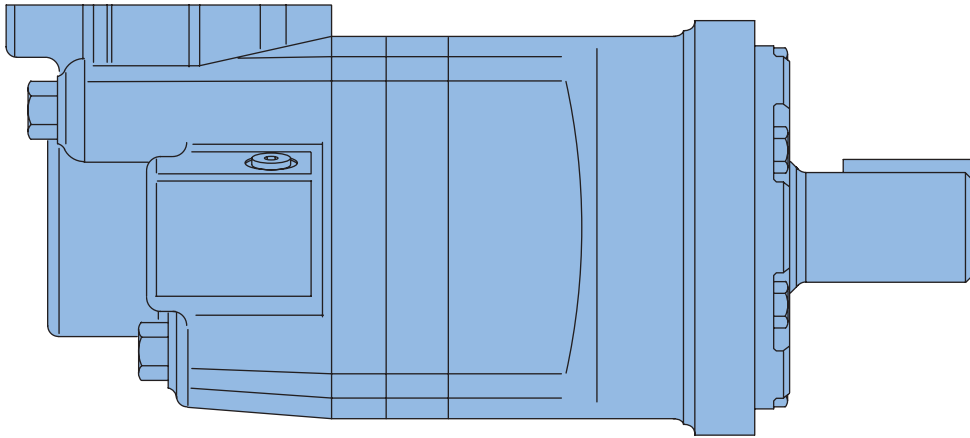

### 6000 SERIES MOTORS

Displ. cm <sup>3</sup> /r [in <sup>3</sup> /r]		195 [11.9]	245 [15.0]	310 [19.0]	390 [23.9]	490 [30.0]	625 [38.0]	735 [45.0]	805 [49.0]	985 [60.0]
Max. Speed (RPM)	Continuous	775	615	485	387	307	241	203	187	153
	Intermittent	866	834	698	570	454	355	303	280	230
@ Flow										
Flow l/min [GPM]	Continuous	150 [40]	150 [40]	150 [40]	150 [40]	150 [40]	150 [40]	150 [40]	150 [40]	150 [40]
	Intermittent	170 [45]	210 [55]	225 [60]	225 [60]	225 [60]	225 [60]	225 [60]	225 [60]	225 [60]
Torque* Nm [lb-in]	Continuous	575 [5100]	735 [6510]	930 [8230]	1155 [10230]	1445 [12800]	1480 [13100]	1378 [12192]	1582 [14004]	1685 [14920]
	Intermittent	860 [7620]	1100 [9740]	1355 [11990]	1635 [14490]	1885 [16670]	1898 [16800]	1699 [15040]	1850 [16377]	1875 [16580]
Pressure Δ bar [Δ PSI]	Continuous	205 [3000]	205 [3000]	205 [3000]	205 [3000]	205 [3000]	170 [2500]	140 [2000]	140 [2000]	140 [2000]
	Intermittent	310 [4500]	310 [4500]	310 [4500]	310 [4500]	275 [4000]	221 [3200]	170 [2500]	170 [2500]	140 [2000]
	Peak	310 [4500]	310 [4500]	310 [4500]	310 [4500]	310 [4500]	240 [3500]	205 [3000]	170 [2500]	170 [2250]
Weight kg [lb]	Standard or Wheel Mount	24,9 [55.0]	25,2 [55.5]	25,6 [56.5]	26,3 [58.0]	27,0 [59.5]	27,9 [61.5]	28,6 [63.0]	29 [64.0]	30,4 [67.0]
	Bearingless	20,2 [44.5]	20,4 [45.0]	20,9 [46.0]	21,5 [47.5]	22,2 [49.0]	23,1 [51.0]	28,3 [52.5]	28,8 [53.5]	30,2 [56.5]

Maximum Case Pressure: See case pressure seal limitation graph.

\*See shaft torque ratings for limitations..

#### Note:

To assure best motor life, run motor for approximately one hour at 30% of rated pressure before application to full load. Be sure motor is filled with fluid prior to any load applications.

#### Maximum Inlet Pressure:

310 bar [4500 PSI]  
Do not exceed Δ pressure rating (see chart above).

#### Maximum Return Pressure:

310 bar [4500 PSI] with case drain line installed.  
Do not exceed Δ pressure rating (see chart above).

#### Δ bar [Δ PSI] :

The true pressure difference between inlet port and outlet port

#### Continuous Rating:

Motor may be run continuously at these ratings

#### Intermittent Operation:

10% of every minute

#### Peak Operation:

1% of every minute

#### Recommended Fluids:

Premium quality, anti-wear type hydraulic oil with a viscosity of not less than 70 SUS at operating temperature.

#### Recommended System Operating Temp.:

-34°C to 82°C [-30°F to 180°F]

#### Recommended Filtration:





per ISO Cleanliness Code, 4406: 20/18/13

# 6000 Series

## Performance Data

Motors run with high efficiency in all areas designated with a number for torque and speed. For best motor life select a motor to run with a torque and speed range shown in the light shaded area.

Performance data is typical at 120 SUS. Actual data may vary slightly from unit to unit in production.

	Continuous		Peak
	Intermittent		No Operation

195cm<sup>3</sup>/r [11.9 in<sup>3</sup>/r]

ΔPressure Bar [PSI]

	[250] 15	[500] 35	[1000] 70	[1500] 105	[2000] 140	[2500] 170	[3000] 205	[3500] 240	[4000] 275	[4500] 310
[.5] 1.9	[280] 30 9	[650] 75 7	[1450] 165 5	[2290] 260 2						
[2] 7.5	[290] 35 38	[680] 75 37	[1500] 170 35	[2340] 265 34	[3100] 350 30	[3880] 440 26	[4140] 470 18			
[4] 15	[300] 35 77	[710] 80 76	[1500] 175 74	[2390] 270 72	[3200] 365 66	[4030] 455 62	[4600] 520 46	[5200] 590 32	[5790] 655 18	
[8] 30	[310] 35 154	[740] 85 153	[1590] 180 148	[2450] 275 144	[3280] 370 131	[4120] 465 119	[4810] 545 116	[5530] 625 99	[6250] 705 83	[6900] 780 65
[12] 45	[320] 35 232	[750] 85 230	[1610] 180 225	[2480] 280 221	[3330] 375 212	[4190] 475 203	[4990] 565 186	[5810] 655 167	[6630] 750 148	[7320] 825 118
[16] 61	[300] 35 309	[730] 80 307	[1600] 180 303	[2470] 280 300	[3340] 375 291	[4210] 475 283	[5090] 575 258	[5900] 665 236	[6710] 760 214	[7470] 845 181
[20] 76	[270] 30 387	[720] 80 384	[1590] 180 379	[2460] 280 374	[3350] 380 365	[4240] 480 356	[5100] 575 332	[5950] 670 306	[6800] 770 280	[7620] 860 247
[24] 91	[240] 25 465	[700] 80 462	[1570] 175 456	[2440] 275 450	[3330] 375 440	[4220] 475 429	[5080] 575 413	[5940] 670 388	[6810] 770 363	
[28] 106	[190] 20 542	[660] 75 539	[1530] 175 532	[2400] 270 526	[3300] 375 514	[4200] 475 502	[5060] 570 476	[5940] 670 448	[6810] 770 421	
[32] 121	[160] 20 620	[630] 70 617	[1500] 170 609	[2370] 270 602	[3270] 370 589	[4160] 470 576	[5040] 570 542	[5920] 670 511	[6790] 765 480	
[36] 136	[120] 15 697	[620] 70 692	[1480] 165 683	[2350] 265 674	[3240] 365 659	[4130] 465 645	[5000] 565 601	[5880] 665 564	[6760] 765 527	
[40] 151	[80] 10 775	[610] 70 770	[1450] 165 759	[2320] 260 749	[3210] 365 733	[4100] 465 718	[4960] 560 666	[5840] 660 624		
[45] 170		[590] 65 866	[1410] 160 854	[2280] 260 843	[3170] 360 825	[4060] 460 808	[4920] 555 749	[5790] 655 702		

245cm<sup>3</sup>/r [15.0 in<sup>3</sup>/r]

ΔPressure Bar [PSI]

	[250] 15	[500] 35	[1000] 70	[1000] 105	[2000] 140	[2500] 170	[3000] 205	[3500] 240	[4000] 275	[4500] 310
[.5] 1.9	[430] 50 7	[860] 95 4	[1890] 215 1							
[2] 7.5	[440] 50 30	[900] 100 29	[1940] 220 26	[2990] 340 24	[3960] 445 21	[4920] 555 17	[5040] 570 11	[5930] 670 6		
[4] 15	[460] 50 61	[940] 105 60	[2000] 225 56	[3060] 345 54	[4080] 460 48	[5090] 575 42	[5680] 640 39	[6630] 750 30	[7570] 855 12	[8520] 965 6
[8] 30	[470] 55 122	[960] 110 120	[2060] 235 116	[3150] 355 113	[4210] 475 104	[5260] 595 95	[6180] 700 81	[7100] 800 67	[8020] 905 53	[9020] 1020 37
[12] 45	[480] 55 183	[970] 110 182	[2080] 235 178	[3180] 360 174	[4270] 480 165	[5360] 605 157	[6390] 720 141	[7420] 840 125	[8450] 955 109	[9510] 1075 92
[16] 61	[450] 50 245	[960] 110 244	[2070] 235 240	[3180] 360 236	[4290] 485 228	[5420] 610 221	[6480] 730 202	[7490] 845 184	[8480] 960 165	[9540] 1180 145
[20] 76	[420] 45 307	[940] 105 306	[2050] 230 301	[3160] 355 297	[4290] 485 287	[5440] 615 277	[6510] 735 257	[7580] 855 238	[8660] 980 218	[9740] 1100 197
[24] 91	[380] 45 368	[920] 105 365	[2020] 230 361	[3120] 355 358	[4260] 480 348	[5400] 610 338	[6490] 735 316	[7590] 860 294	[8680] 980 271	
[28] 106	[330] 35 430	[870] 100 426	[1980] 225 421	[3100] 350 416	[4240] 480 404	[5380] 610 376	[6480] 730 358	[7580] 855 340	[8670] 980 322	
[32] 121	[290] 35 491	[800] 90 489	[1920] 215 481	[3050] 345 475	[4170] 470 461	[5290] 600 448	[6410] 725 423	[7520] 850 398	[8640] 975 373	
[36] 136	[250] 30 556	[730] 80 549	[1850] 210 543	[2980] 335 537	[4060] 460 524	[5150] 580 509	[6300] 710 482	[7440] 840 456		
[40] 151	[200] 25 615	[690] 80 612	[1790] 200 606	[2940] 330 599	[4010] 455 585	[5130] 580 570	[6190] 700 540	[7100] 800 510		
[45] 170		[570] 65 688	[1760] 200 682	[2860] 325 674	[3960] 445 658	[5070] 575 641	[6080] 685 608	[6990] 755 574		
[50] 189			[1720] 195 758	[2800] 315 749	[3890] 440 731	[4920] 555 712	[5940] 670 676			
[55] 208			[1670] 190 834	[2740] 310 824	[3820] 430 804	[4890] 550 783	[5880] 665 744			

[5790]  
655  
702 } Torque [lb-in]  
Nm  
Speed RPM

# 6000 Series

## Performance Data

Motors run with high efficiency in all areas designated with a number for torque and speed. For best motor life select a motor to run with a torque and speed range shown in the light shaded area.

Performance data is typical at 120 SUS. Actual data may vary slightly from unit to unit in production.

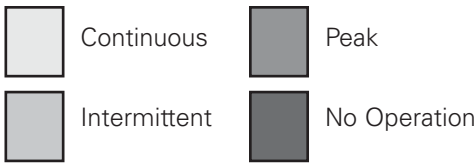

**310cm<sup>3</sup>/r [19.0 in<sup>3</sup>/r]**  
 $\Delta$ Pressure Bar [PSI]

	[250] 15	[500] 35	[1000] 70	[1500] 105	[2000] 140	[2500] 170	[3000] 205	[3500] 240	[4000] 275	[4500] 310
[.5] 1.9	[530] 60 6	[1120] 125 4	[2440] 275 1							
[2] 7.5	[540] 60 24	[1150] 130 23	[2460] 280 22	[3620] 410 20	[4780] 540 17	[5690] 645 14	[6670] 755 10	[7780] 880 4		
[4] 15	[550] 60 48	[1180] 135 47	[2560] 290 45	[3800] 430 42	[5030] 570 38	[6050] 685 32	[7070] 800 24	[8260] 935 17	[9070] 1025 10	[9530] 1075 3
[8] 30	[560] 65 96	[1250] 140 95	[2650] 300 91	[3970] 450 87	[5280] 595 81	[6480] 730 73	[7710] 870 64	[8740] 985 55	[9770] 1105 46	[10990] 1240 35
[12] 45	[570] 65 144	[1260] 140 143	[2690] 305 140	[4050] 460 135	[5420] 610 129	[6730] 760 121	[8040] 910 111	[9260] 1045 99	[10490] 1185 88	[11800] 1335 76
[16] 61	[540] 60 193	[1230] 140 192	[2660] 300 188	[4060] 460 184	[5450] 615 178	[6800] 770 167	[8150] 920 156	[9400] 1060 141	[10660] 1205 126	[11990] 1355 109
[20] 76	[510] 60 242	[1200] 135 241	[2630] 295 236	[4040] 455 232	[5450] 615 226	[6820] 770 216	[8190] 925 201	[9520] 1075 184	[10840] 1225 167	
[24] 91	[480] 55 290	[1160] 130 289	[260] 295 282	[4020] 455 279	[5440] 615 273	[6840] 775 260	[8230] 930 248	[9560] 1080 232	[10900] 1230 215	
[28] 106	[420] 45 339	[1130] 130 336	[2570] 290 333	[3990] 450 328	[5420] 610 320	[6820] 770 308	[8220] 930 295	[9520] 1075 276	[10840] 1225 257	
[32] 121	[360] 40 388	[1100] 125 384	[2510] 285 381	[3920] 445 375	[5330] 600 368	[6750] 765 354	[8170] 920 341	[9440] 1065 320		
[36] 136	[300] 35 436	[1060] 120 430	[2440] 275 421	[3830] 435 416	[5220] 590 410	[6660] 750 396	[8100] 915 383	[9330] 1055 360		
[40] 151	[270] 30 485	[1020] 115 478	[2400] 270 466	[3780] 425 461	[5150] 580 456	[6580] 745 441	[8020] 905 427	[9220] 1040 403		
[50] 189		[982] 110 597	[2180] 245 582	[3420] 385 576	[4660] 525 570	[6050] 685 551	[7440] 840 534			
[60] 227			[1960] 220 698	[3250] 365 691	[4540] 515 684	[5750] 650 661	[7080] 800 641			

**390cm<sup>3</sup>/r [23.9 in<sup>3</sup>/r]**  
 $\Delta$ Pressure Bar [PSI]

	[250] 15	[500] 35	[1000] 70	[1500] 105	[2000] 140	[2500] 170	[3000] 205	[3500] 240	[4000] 275	[4500] 310
[1] 3.8	[760] 85 4	[1570] 175 2	[3230] 365 1							
[2] 7.5	[780] 90 19	[1610] 180 18	[3270] 370 17	[4910] 555 16	[6440] 730 14	[7760] 875 12	[9080] 1025 9	[10590] 1195 4		
[4] 15	[800] 90 38	[1640] 185 38	[3300] 375 37	[4970] 560 35	[6570] 740 33	[8160] 920 29	[9570] 1080 22	[11270] 1275 14	[12120] 1370 5	[14490] 1635 1
[8] 30	[810] 90 77	[1650] 185 76	[3370] 380 74	[5080] 575 72	[6740] 760 68	[8430] 950 65	[10050] 1135 55	[11620] 1315 45	[12880] 1455 33	[14480] 1635 21
[12] 45	[800] 90 115	[1620] 185 115	[3390] 385 112	[5130] 580 109	[6810] 770 105	[8520] 965 100	[10190] 1150 91	[11860] 1340 81	[13640] 1540 79	
[16] 61	[750] 85 154	[1600] 180 154	[3380] 380 151	[5120] 580 147	[6820] 770 143	[8560] 965 132	[10230] 1155 126	[11920] 1345 116		
[20] 76	[680] 75 193	[1580] 180 193	[3360] 380 189	[5120] 580 187	[6840] 775 182	[8590] 970 175	[10280] 1160 162	[11980] 1355 152		
[24] 91	[620] 70 232	[1520] 170 230	[3280] 370 229	[5060] 570 225	[6780] 765 220	[8530] 965 212	[10240] 1155 204			
[28] 106	[570] 65 270	[1460] 165 268	[3210] 365 266	[5000] 565 261	[6730] 760 256	[8480] 960 248	[10200] 1150 236			
[32] 121	[530] 60 309	[1420] 160 306	[3140] 355 304	[4930] 555 299	[6640] 750 292	[8380] 945 282	[10120] 1145 269			
[36] 136	[450] 50 348	[1370] 155 346	[3010] 340 340	[4840] 545 336	[6500] 730 329	[8250] 930 317	[10000] 1130 301			
[40] 151	[380] 45 387	[1320] 150 386	[2880] 325 380	[4740] 535 375	[6460] 730 368	[8120] 915 359				
[50] 189		[1140] 130 482	[2650] 300 475	[4540] 515 469	[6440] 730 460	[8050] 910 449				
[60] 227			[2460] 280 570	[4430] 500 562	[6360] 720 552	[7860] 890 538				

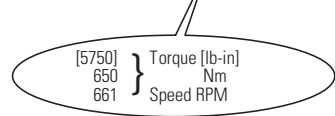

# 6000 Series

## Performance Data

Motors run with high efficiency in all areas designated with a number for torque and speed. For best motor life select a motor to run with a torque and speed range shown in the light shaded area.

Performance data is typical at 120 SUS. Actual data may vary slightly from unit to unit in production.

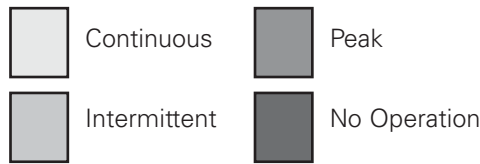

490cm<sup>3</sup>/r [30.0 in<sup>3</sup>/r]  
 ΔPressure Bar [PSI]

	[250] 15	[500] 35	[1000] 70	[1500] 105	[2000] 140	[2500] 170	[3000] 205	[3500] 240	[4000] 275
[1] 3,8	[1010] 115 7	[1200] 235 7	[4260] 480 5	[6140] 695 3					
[2] 7,5	[1020] 115 15	[2110] 240 14	[4270] 480 13	[6280] 710 12	[8350] 945 11	[10420] 1175 8	[12140] 1370 3		
[4] 15	[1030] 115 30	[2100] 235 30	[4280] 485 29	[6410] 725 28	[8500] 960 27	[10590] 1195 25	[12500] 1410 21	[14580] 1645 17	[16670] 1885 12
[8] 30	[1020] 115 60	[2090] 235 60	[4290] 485 59	[6490] 735 57	[8620] 975 54	[10740] 1215 51	[12800] 1445 45	[14930] 1685 38	
[12] 45	[1000] 115 91	[2080] 235 91	[4290] 485 89	[6500] 735 87	[8650] 975 84	[10800] 1220 79	[12890] 1455 71		
[16] 61	[110] 960 122	[2060] 235 122	[4260] 480 121	[6480] 730 118	[8650] 975 114	[10820] 1220 109	[12900] 1460 100		
[20] 76	[900] 100 153	[1980] 225 152	[4180] 470 150	[6420] 725 147	[8620] 975 144	[10820] 1220 139			
[24] 91	[850] 95 184	[1930] 220 184	[4150] 470 181	[6390] 720 180	[8580] 970 176	[10770] 1215 171			
[28] 106	[740] 85 215	[1840] 210 214	[4070] 460 211	[6290] 710 208	[8500] 960 204	[10720] 1210 198			
[32] 121	[690] 80 245	[1710] 195 244	[3970] 450 241	[6190] 700 237	[8420] 950 232	[10660] 1205 226			
[36] 136	[670] 75 276	[1560] 175 275	[3860] 435 272	[6080] 685 265	[8340] 940 260	[10420] 1175 255			
[40] 151	[570] 65 307	[1400] 160 306	[3750] 425 303	[5970] 675 295	[8140] 920 290	[10180] 1150 284			
[50] 189		[1140] 130 382	[3240] 365 379	[5220] 590 369	[7620] 860 362				
[60] 227			[2860] 325 454	[4860] 550 442	[7140] 805 435				

Flow LPM [GPM]

625cm<sup>3</sup>/r [38.0 in<sup>3</sup>/r]  
 ΔPressure Bar [PSI]

	[250] 15	[500] 35	[1000] 70	[1500] 105	[2000] 140	[2500] 170	[3000] 205	[3200] 221
[1] 3,8	[1060] 120 5	[2205] 250 5	[4515] 510 4	[6690] 755 2				
[2] 7,5	[1090] 125 12	[2300] 260 12	[4720] 535 13	[7025] 795 10	[9360] 1060 6			
[4] 15	[1145] 130 24	[2450] 275 24	[5052] 570 24	[7520] 850 21	[9410] 1065 16	[12700] 1434 13		
[8] 30	[1195] 135 45	[2600] 295 45	[5350] 605 44	[8195] 925 42	[11220] 1270 37	[13100] 1480 35	[15800] 1785 32	[16800] 1898 30
[12] 45	[1200] 135 72	[2600] 295 72	[5390] 610 71	[8145] 920 68	[11770] 1330 64	[13000] 1469 60	[15700] 1774 56	
[16] 61	[1120] 125 94	[2530] 285 94	[5340] 605 92	[8105] 915 89	[11740] 1325 85	[13000] 1469 83		
[20] 76	[1050] 120 120	[2465] 280 119	[5285] 595 117	[8080] 915 115	[11725] 1325 110			
[24] 91	[950] 105 144	[2365] 265 143	[5180] 585 140	[7990] 905 138	[11705] 1320 132			
[28] 106	[855] 95 169	[2255] 255 168	[5080] 575 165	[7915] 895 162	[11640] 1315 156			
[32] 121	[730] 80 193	[2140] 240 192	[4960] 560 188	[7775] 880 185	[11505] 1300 179			
[36] 136	[555] 65 217	[1965] 220 216	[4780] 540 213	[7585] 855 210				
[40] 151	[380] 45 241	[1790] 200 240	[4600] 520 238	[7395] 835 236				
[50] 189			[4180] 470 296	[6985] 790 290				
[60] 227			[3800] 430 353	[6600] 745 345				

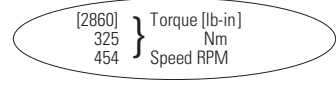



# 6000 Series

## Performance Data

Motors run with high efficiency in all areas designated with a number for torque and speed. For best motor life select a motor to run with a torque and speed range shown in the light shaded area.

Performance data is typical at 120 SUS. Actual data may vary slightly from unit to unit in production.

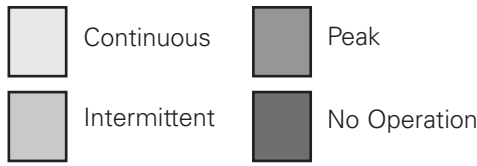

**735cm<sup>3</sup>/r [45.0 in<sup>3</sup>/r]**  
**ΔPressure Bar [PSI]**

	[250] 15	[500] 35	[750] 50	[1000] 70	[1250] 85	[1500] 105	[1750] 120	[2000] 140	[2250] 155	[2500] 170
[1] 3,8	[1311] 148 4	[2775] 314 4	[4200] 475 3	[5480] 619 3	[7000] 791 2					
[2] 7,5	[1340] 151 10	[2856] 323 10	[4535] 512 10	[5809] 656 10	[7551] 853 9	[8685] 981 7	[10182] 1150 6	[11121] 1257 5		
[4] 15	[1253] 142 20	[2854] 322 20	[4363] 493 19	[5813] 657 18	[7272] 822 17	[8714] 985 16	[10135] 1145 14	[11537] 1303 13	[12970] 1465 11	[15040] 1699 11
[8] 30	[1290] 146 40	[2889] 326 39	[4540] 513 38	[6130] 693 38	[7703] 870 37	[9202] 1040 37	[10666] 1205 35	[12192] 1378 33	[13713] 1549 32	
[12] 45	[1277] 144 61	[2821] 319 60	[4528] 512 59	[6180] 698 58	[7795] 881 57	[9338] 1055 56	[10877] 1229 54	[12419] 1403 52		
[16] 61	[1196] 135 82	[2753] 311 80	[4478] 506 79	[6148] 695 78	[7768] 878 77	[9376] 1059 76	[10984] 1241 74			
[20] 76	[1092] 123 102	[2794] 316 101	[4320] 488 101	[6021] 680 99	[7697] 870 97	[9311] 1052 96	[10907] 1232 93			
[24] 91	[1206] 136 123	[2556] 289 122	[4162] 470 120	[5871] 663 119	[7564] 855 118	[9289] 1049 116				
[28] 106	[1083] 122 145	[2338] 264 142	[4040] 456 141	[5666] 640 139	[7365] 832 137	[9022] 1019 135				
[32] 121	[950] 107 163	[2110] 238 162	[3795] 429 162	[5457] 617 159	[7122] 805 159	[8828] 997 156				
[36] 136	[726] 82 184	[1845] 208 183	[3517] 397 182	[5223] 590 181	[6853] 774 179					
[40] 151	[515] 58 203	[2227] 252 202	[3270] 369 202	[4965] 561 201	[6672] 754 199					
[50] 189			[3869] 437 254	[4148] 469 252	[5850] 661 250					
[60] 227				[4856] 549 303	[6604] 746 301					

**805cm<sup>3</sup>/r [49.0 in<sup>3</sup>/r]**  
**ΔPressure Bar [PSI]**

	[250] 15	[500] 35	[750] 50	[1000] 70	[1250] 85	[1500] 105	[1750] 120	[2000] 140	[2250] 155	[2500] 170
[1] 3,8	[1455] 164 4	[3100] 350 4	[4680] 529 2	[6031] 681 2	[7799] 881 1					
[2] 7,5	[1483] 168 9	[3173] 359 9	[5121] 579 9	[6432] 727 8	[8510] 961 7	[9633] 1088 6	[11319] 1279 5	[12127] 1370 5		
[4] 15	[1547] 175 19	[3331] 376 19	[5292] 598 18	[6744] 762 17	[8714] 984 16	[10075] 1138 15	[11352] 1283 14	[12539] 1417 12	[14564] 1645 11	[16377] 1850 10
[8] 30	[1599] 181 35	[3473] 392 35	[5415] 612 34	[7039] 795 33	[8934] 1009 32	[10629] 1201 31	[11842] 1338 29	[14004] 1582 29	[15441] 1745 28	
[12] 45	[1599] 181 56	[3469] 392 56	[5415] 612 55	[7093] 801 53	[9024] 1020 53	[10658] 1204 52	[12283] 1388 50	[13726] 1551 50		
[16] 61	[1543] 174 73	[3395] 384 73	[5357] 605 72	[7032] 794 70	[8983] 1015 69	[10640] 1202 68	[12010] 1357 67			
[20] 76	[1457] 165 93	[3312] 374 92	[5292] 598 91	[6968] 787 89	[8943] 1010 88	[10583] 1196 87	[12146] 1372 86			
[24] 91	[1352] 153 112	[3183] 360 112	[5088] 575 111	[6811] 769 110	[8812] 996 108	[10411] 1176 106				
[28] 106	[1213] 137 131	[3055] 345 131	[5047] 570 131	[6713] 758 129	[8681] 981 128	[10411] 1176 127				
[32] 121	[1075] 121 150	[2907] 328 149	[4884] 552 149	[6546] 740 146	[8395] 949 145	[10060] 1137 144				
[36] 136	[823] 93 168	[2692] 304 168	[4663] 527 168	[6320] 714 167	[8118] 917 165					
[40] 151	[592] 67 187	[2477] 280 186	[4426] 500 186	[6085] 688 185	[7832] 885 184					
[50] 189		[2730] 308 234	[4214] 476 233	[5849] 661 231	[7603] 859 230					
[60] 227			[3806] 430 280	[5459] 617 277	[7407] 837 275					







# 6000 Series

## Performance Data

Motors run with high efficiency in all areas designated with a number for torque and speed. For best motor life select a motor to run with a torque and speed range shown in the light shaded area.

Performance data is typical at 120 SUS. Actual data may vary slightly from unit to unit in production.

	Continuous		Peak
	Intermittent		No Operation

		985cm <sup>3</sup> /r [60.0 in <sup>3</sup> /r] ΔPressure Bar [PSI]							
		[250]	[500]	[750]	[1000]	[1250]	[1500]	[1750]	[2000]
		15	35	50	70	85	105	120	140
Flow LPM [GPM]	[1] 3.8	[1890] 215 3	[4110] 465 3	[5730] 645 2	[7640] 865 2	[9550] 1080 1			
	[2] 7.5	[1910] 215 8	[4140] 470 8	[6270] 710 7	[8300] 940 7	[10420] 1175 6	[12500] 1410 5	[13860] 1565 4	[14920] 1685 3
	[4] 15	[1980] 225 15	[4290] 485 15	[6480] 775 15	[8540] 965 14	[10670] 1205 14	[12800] 1445 13	[13900] 1570 13	[15850] 1790 12
	[8] 30	[2030] 230 30	[4400] 495 30	[6630] 750 30	[8790] 995 29	[10940] 1235 28	[13090] 1480 27	[14500] 1640 26	[16580] 1875 25
	[12] 45	[2020] 230 45	[4390] 495 45	[6630] 750 45	[8860] 1000 44	[11050] 1250 43	[13240] 1495 42	[15040] 1700 41	
	[16] 61	[2010] 225 61	[4320] 490 61	[6560] 740 61	[8790] 995 60	[11000] 1245 59	[13260] 1500 58		
	[20] 76	[1910] 215 77	[4220] 475 77	[6480] 730 76	[8720] 985 76	[10950] 1235 75	[13160] 1485 74		
	[24] 91	[1810] 205 92	[4060] 460 92	[6230] 705 92	[8500] 960 91	[10790] 1220 90	[12990] 1470 89		
	[28] 106	[1620] 185 107	[3920] 445 107	[6180] 700 107	[8420] 950 106	[10630] 1200 105	[12820] 1450 103		
	[32] 121	[1480] 165 123	[3740] 425 123	[5980] 675 122	[8200] 925 121	[10280] 1160 120			
	[36] 136	[1140] 130 138	[3490] 395 138	[5710] 645 138	[7930] 895 137	[9940] 1125 135			
	[40] 151	[850] 95 153	[3240] 365 153	[5420] 610 152	[7640] 865 151	[9590] 1085 150			
	[50] 189		[2960] 325 191	[5160] 585 190	[7350] 830 189	[9310] 1050 188			
	[60] 227			[4660] 525 230	[7160] 810 229	[9070] 1025 226			

[7160]  
810  
229 } Torque [lb-in]  
Nm  
Speed RPM

# 6000 Series

## Dimensions

### Standard Mount

## Ports

- 1 5/16 -12 UN-2B SAE O-ring Staggered Ports (2)
- 7/16 -20 UNF-2B SAE O-ring Case Drain Port (1) or
- 4 Bolt 3/4 inch Split Flange Ports (2)
- 7/16 -20 UNF-2B SAE O-ring Case Drain Port (1) or
- G 1 (BSP) Staggered Ports (2)
- G 1/4 (BSP) Case Drain Port (1) or
- 1 5/16 UN-2B SAE O-ring Staggered Ports (2) with Shuttle
- 9/16 -20 UNF-2B SAE O-ring Case Drain Port (1)

## Standard Rotation Viewed from Shaft End

- Port A Pressurized — CW
- Port B Pressurized — CCW

## Standard Mount

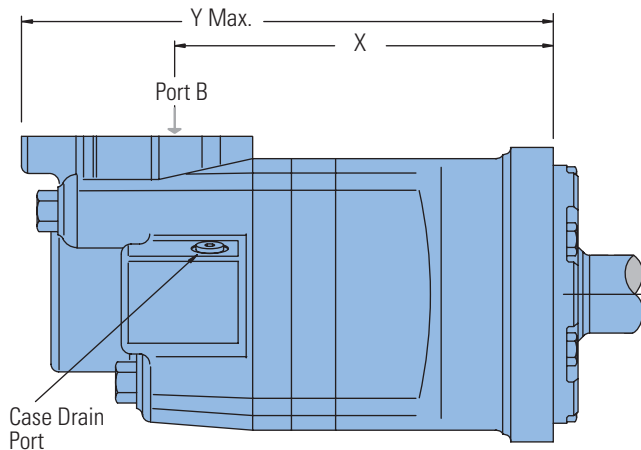

## Standard SAE CC Flange

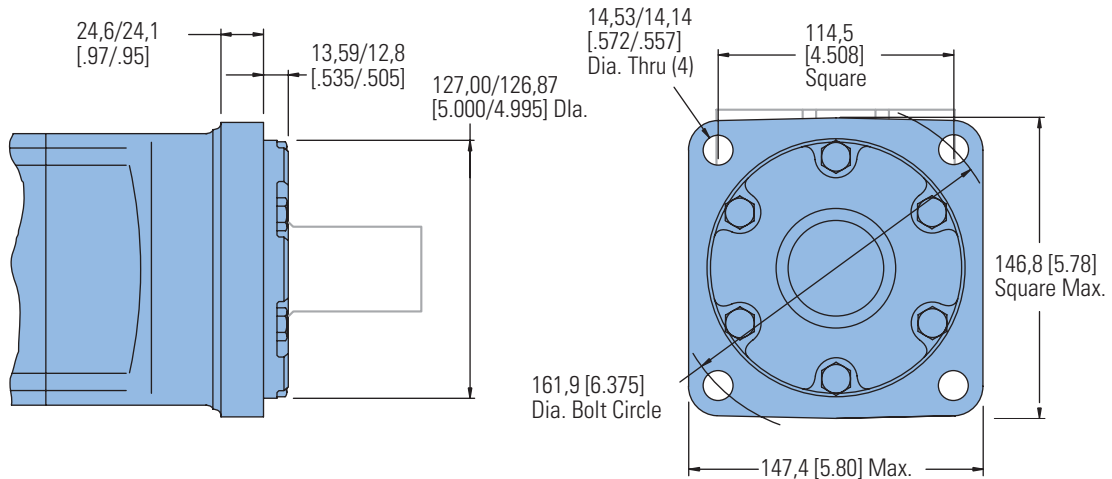

## STANDARD MOTOR MOUNT DIMENSIONS

Displacement cm <sup>3</sup> /r [in <sup>3</sup> /r]	X mm [inch]	Y mm [inch]
195 [11.9]	187,5 [ 7.38]	270,0 [10.63]
245 [15.0]	193,0 [ 7.60]	275,6 [10.85]
310 [19.0]	200,4 [ 7.89]	283,0 [11.14]
390 [23.9]	209,0 [ 8.23]	291,6 [11.48]
490 [30.0]	220,2 [ 8.67]	302,8 [11.92]
625 [38.0]	235,0 [ 9.25]	317,5 [12.50]
985 [60.0]	274,6 [10.81]	357,1 [14.06]

# 6000 Series

Dimensions

Wheel Mount

## Ports

- 1 5/16 -12 UN-2B SAE O-ring Staggered Ports (2)
- 7/16 -20 UNF-2B SAE O-ring Case Drain Port (1) or
- 4 Bolt 3/4 inch Split Flange Ports (2)
- 7/16 -20 UNF-2B SAE O-ring Case Drain Port (1) or
- G 1 (BSP) Staggered Ports (2)
- G 1/4 (BSP) Case Drain Port (1) or
- 1 5/16 UN-2B SAE O-ring Staggered Ports (2) with Shuttle
- 9/16 -20 UNF-2B SAE O-ring Case Drain Port (1)

## Standard Rotation Viewed from Shaft End

- Port A Pressurized — CW
- Port B Pressurized — CCW

## Wheel Mount

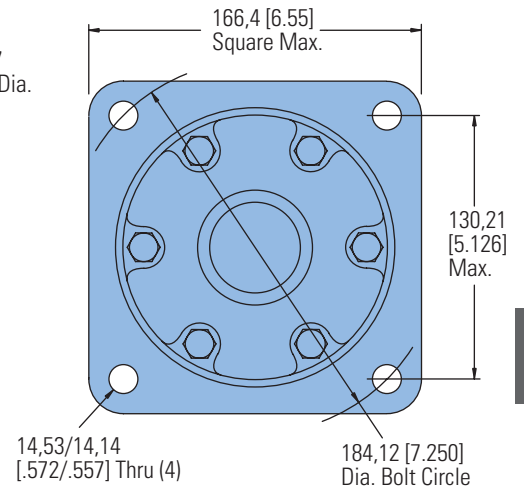
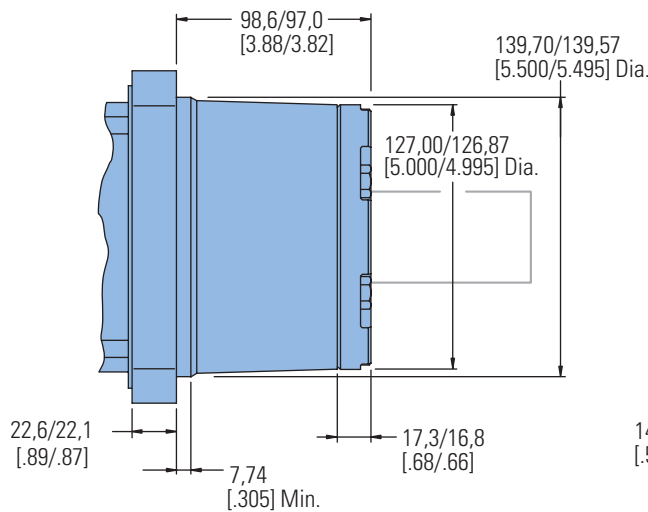
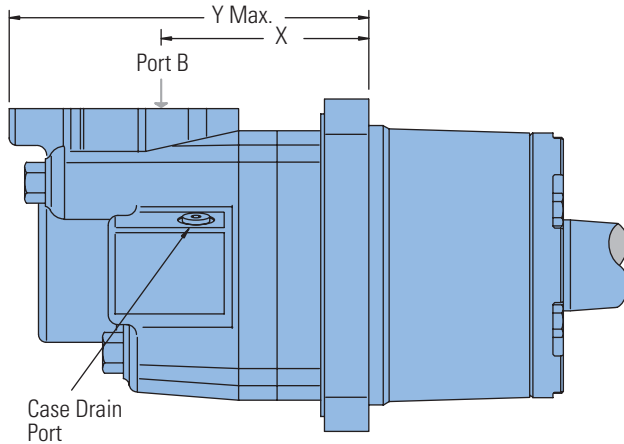

C-5

### WHEEL MOUNT MOTOR DIMENSIONS

Displacement cm <sup>3</sup> /r [in <sup>3</sup> /r]	X mm [inch]	Y mm [inch]
195 [11.9]	102,6 [4.04]	185,2 [7.29]
245 [15.0]	108,2 [4.26]	190,8 [7.51]
310 [19.0]	115,6 [4.55]	198,1 [7.80]
390 [23.9]	124,5 [4.90]	207,1 [8.15]
490 [30.0]	135,4 [5.33]	217,9 [8.58]
625 [38.0]	150,1 [5.91]	232,7 [9.16]
985 [60.0]	189,7 [7.47]	272,5 [10.73]

# 6000 Series

## Dimensions

Global Mount (ISO)

## Ports

- 1 5/16 -12 UN-2B SAE O-ring Staggered Ports (2)
- 7/16 -20 UNF-2B SAE O-ring Case Drain Port (1) or
- 4 Bolt 3/4 inch Split Flange Ports (2)
- 7/16 -20 UNF-2B SAE O-ring Case Drain Port (1) or
- G 1 (BSP) Staggered Ports (2)
- G 1/4 (BSP) Case Drain Port (1) or
- 1 5/16 UN-2B SAE O-ring Staggered Ports (2) with Shuttle
- 9/16 -20 UNF-2B SAE O-ring Case Drain Port (1)

## Standard Rotation Viewed from Shaft End

- Port A Pressurized — CW
- Port B Pressurized — CCW

## Global Mount (ISO)

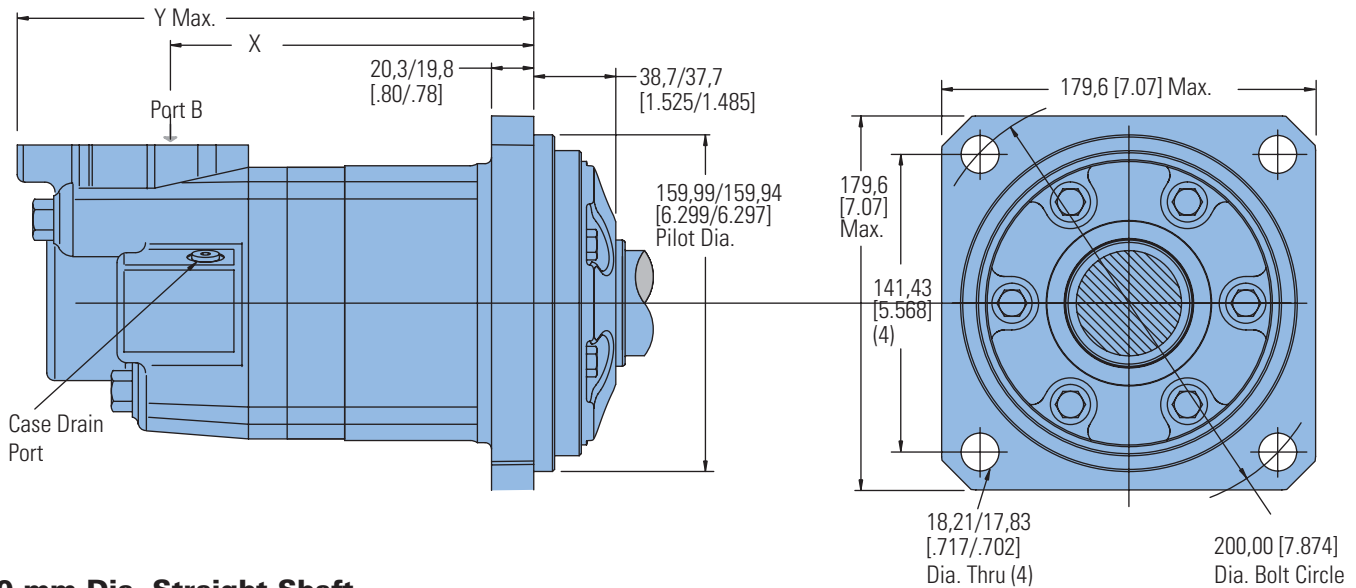

## 50 mm Dia. Straight Shaft

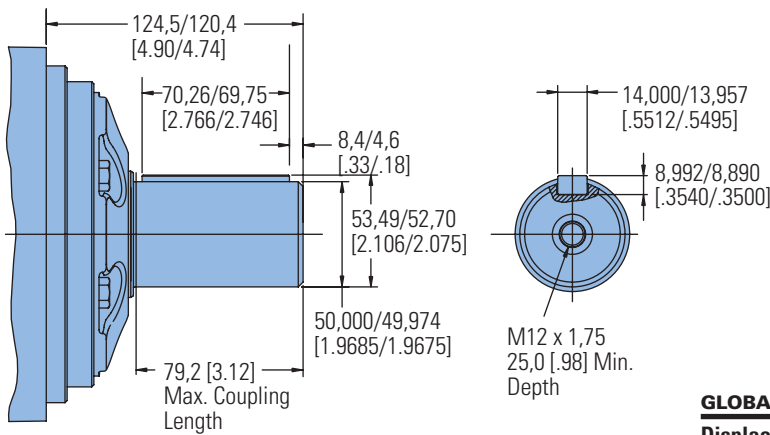

## GLOBAL MOUNT MOTOR DIMENSIONS

Displacement cm <sup>3</sup> /r [in <sup>3</sup> /r]	X mm [inch]	Y mm [inch]
310 [19.0]	182,4 [ 7.18]	264,9 [10.43]
390 [24.0]	191,0 [ 7.52]	273,6 [10.77]
490 [30.0]	202,2 [ 7.96]	284,7 [11.21]
625 [38.0]	216,9 [ 8.54]	299,5 [11.79]
800 [45.0]	229,4 [ 9.03]	312,2 [12.29]
800 [49.0]	236,7 [ 9.32]	319,3 [12.57]
985 [60.0]	256,5 [10.10]	339,1 [13.35]

# 6000 Series

Dimensions

Bearingless

## Ports

- 1 5/16 -12 UN-2B SAE O-ring Staggered Ports (2)
- 7/16 -20 UNF-2B SAE O-ring Case Drain Port (1) or
- 4 Bolt 3/4 inch Split Flange Ports (2)
- 7/16 -20 UNF-2B SAE O-ring Case Drain Port (1) or
- G 1 (BSP) Staggered Ports (2)
- G 1/4 (BSP) Case Drain Port (1) or
- 1 5/16 UN-2B SAE O-ring Staggered Ports (2) with Shuttle
- 9/16 -20 UNF-2B SAE O-ring Case Drain Port (1)

## Bearingless

## Standard Rotation Viewed from Shaft End

- Port A Pressurized — CW
- Port B Pressurized — CCW

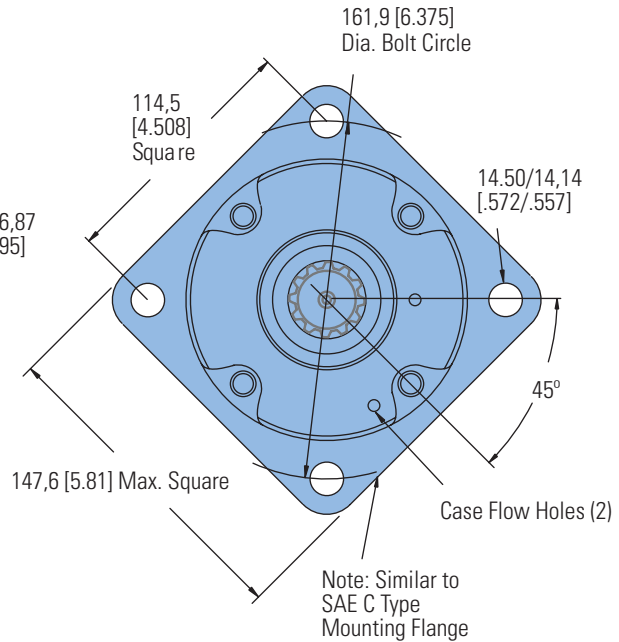
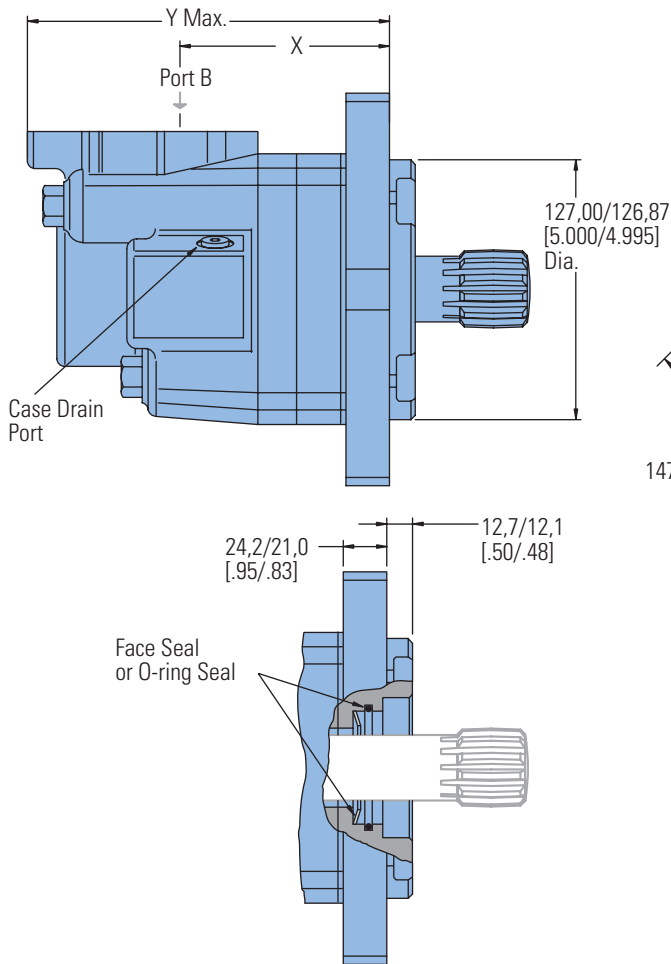

For 6000 bearingless motor application information, contact your Eaton representative (mating coupling blanks available from Eaton Hydraulics).

### Note:

After machining blank, part must be hardened per Eaton specification.

- C 47,2 [1.86] Dia.
- D 111,5 [4.39] Max.
- E 106,4 [4.19] Full Form Dia.
- F 6,9 [.27] Min. Full Form Dia.
- G 10,2 [.40] Min.
- H 86,1 [3.39] Max.
- J 66,5 [2.62] Dia.

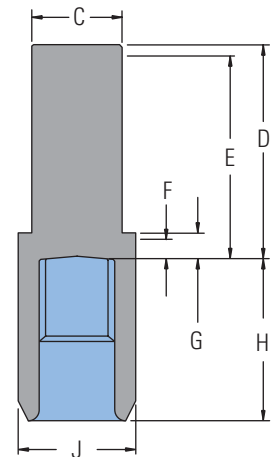

Mating Coupling Blank  
Eaton Part No. 12778-002

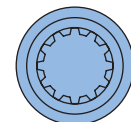

### BEARINGLESS MOTOR DIMENSIONS

Displacement cm <sup>3</sup> /r [in <sup>3</sup> /r]	X mm [inch]	Y mm [inch]
195 [11.9]	105,4 [4.15]	188,0 [7.40]
245 [15.0]	111,0 [4.37]	193,5 [7.62]
310 [19.0]	118,4 [4.66]	200,9 [7.91]
390 [23.9]	127,3 [5.01]	209,6 [8.25]
490 [30.0]	138,2 [5.44]	220,7 [8.69]
625 [38.0]	152,9 [6.02]	235,5 [9.27]
985 [60.0]	192,8 [7.59]	275,1 [10.83]

C-5

# 6000 Series

## Installation Information

### Bearingless

- 1 Internal spline in mating part to be as follows: Material to be ASTM A304, 8620H. Carbonize to a hardness of 60-64 HRc with case depth (to 50HRc) of 0,076 - 1,02 [.030 - .040] (dimensions apply after heat treat).
- 2 Mating part to have critical dimensions as shown. Oil holes must be provided and open for proper oil circulation.
- 3 Seal to be furnished with motor for proper oil circulation thru splines.

- 4 Some means of maintaining clearance between shaft and mounting flange must be provided.
- 5 Similar to SAE "C" Four Bolt Flange..
- 6 Counterbore designed to adapt to a standard sleeve bearing 50,010 - 50,038 [1.9689 - 1.9700] ID by 60,051 - 60,079 [2.3642 - 2.3653] O.D. (Oilite bronze sleeve bearing).

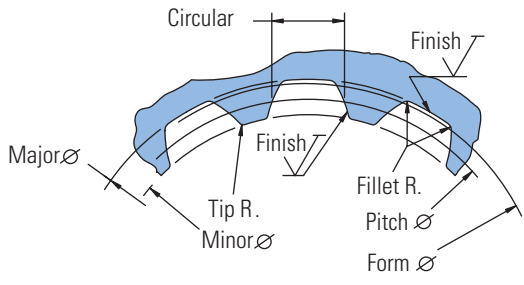
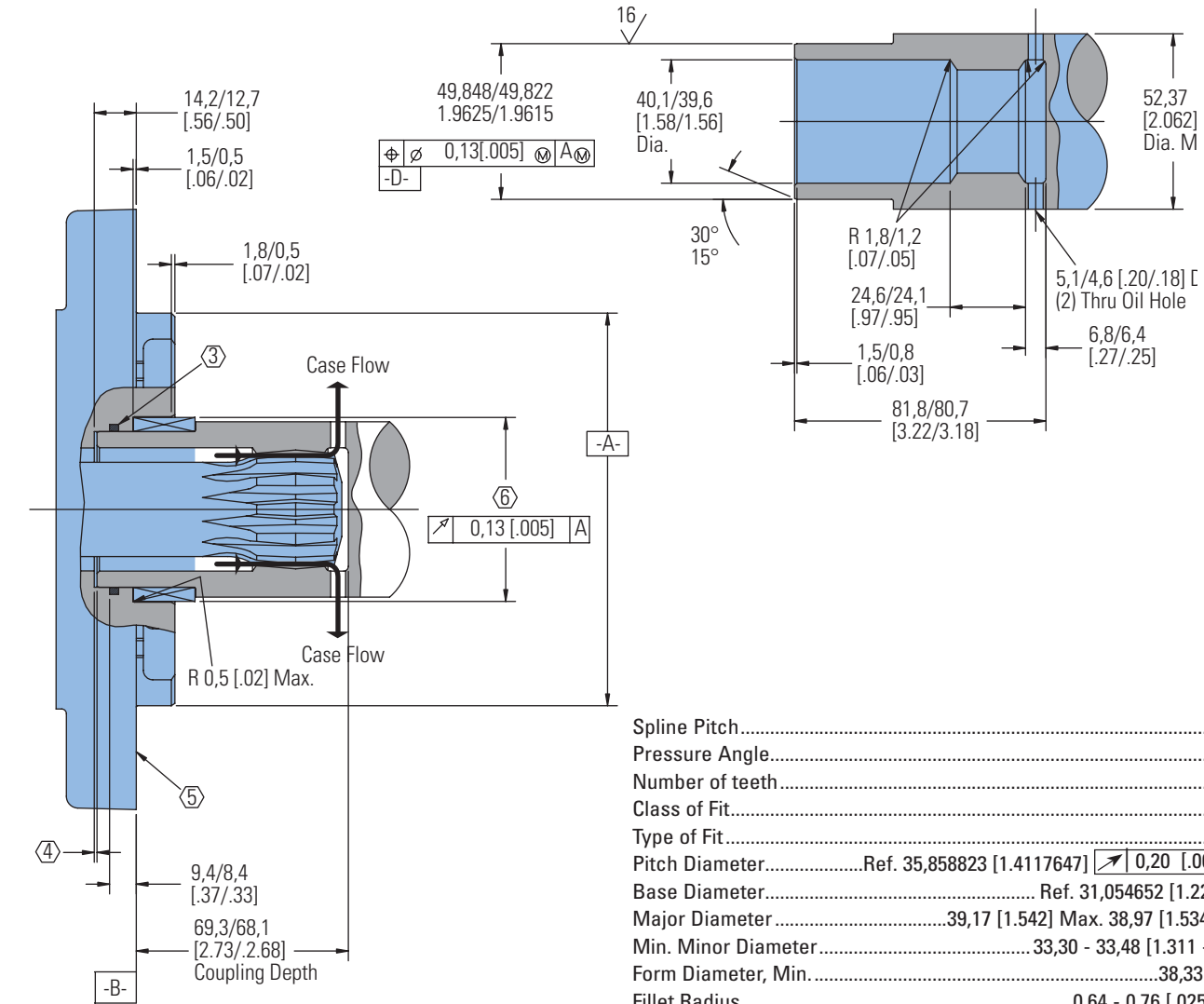

Spline Pitch.....	8.5/17
Pressure Angle.....	30°
Number of teeth.....	12
Class of Fit.....	Ref. 5
Type of Fit.....	Side
Pitch Diameter.....	Ref. 35,858823 [1.4117647] $\sqrt{0,20} [0,008] D$
Base Diameter.....	Ref. 31,054652 [1.2226241]
Major Diameter.....	39,17 [1.542] Max. 38,97 [1.534] Min..
Min. Minor Diameter.....	33,30 - 33,48 [1.311 - 1.318]
Form Diameter, Min.....	38,33 [1.509]
Fillet Radius.....	0,64 - 0,76 [.025 - .030]
Tip Radius.....	0,25 - 0,51 [.010 - .020]
Finish.....	1,6 (63)
Involute Profile Variation.....	+0,000 -0,025 [+0.0000 -0.0010]
Total Index Variation.....	0,038 [0.0015]
Lead Variation.....	0,013 [0.0005]
Circular Space Width:	
Maximum Actual.....	5,898 [0.2322]
Minimum Effective.....	5,804 [0.2285]
Maximum Effective.....	Ref. 5,857 [0.2306]
Minimum Actual.....	Ref. 5,834 [0.2297]
Dimension Between Two Pins.....	Ref. 26,929 - 27,084 [1.0602 - 1.0663]
Pin Diameter.....	6,223 [0.2450] Pins to Have 4,0 [0.160]
	Wide Flat for Root Clearance

# 6000 Series

## Dimensions

### Shafts Splined

#### 1 1/2 Inch Straight

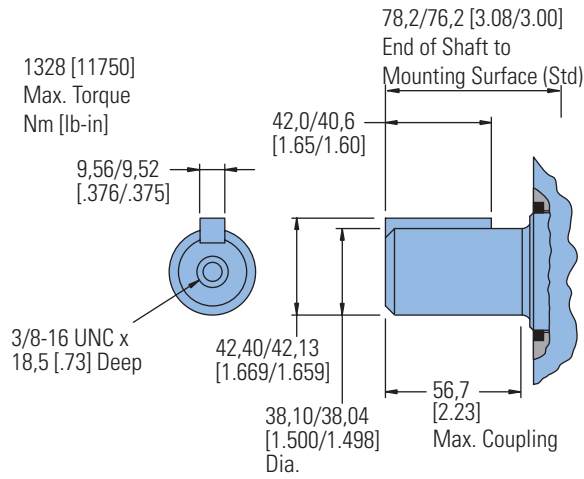

#### 1 3/4 Inch Tapered

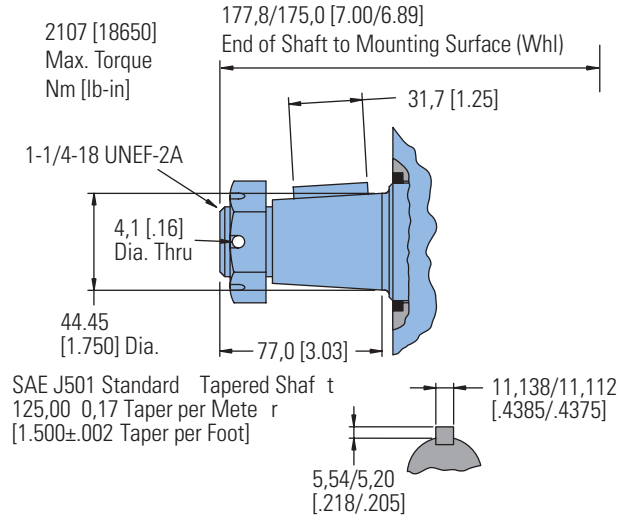

#### 1 1/2 Inch 17 Tooth Splined

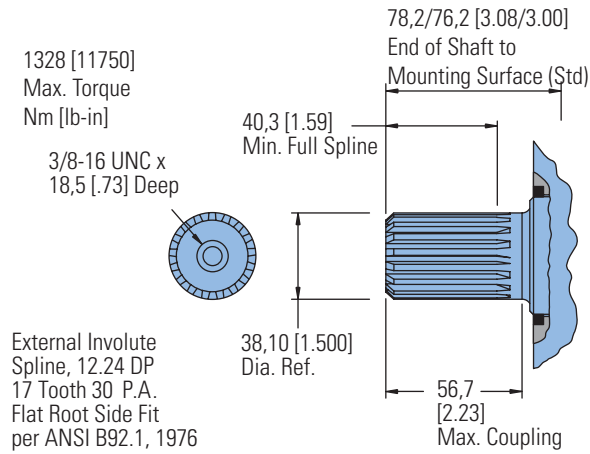

#### Tapered Shaft Hub Data

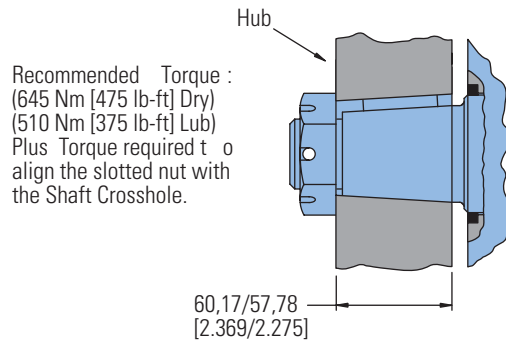

#### 40 mm Straight

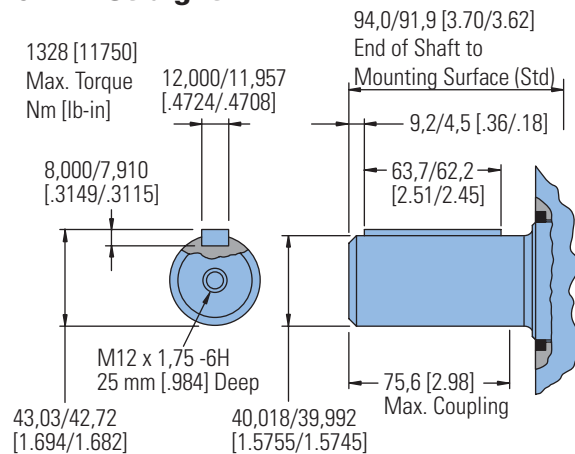

#### Slotted Hexagon Nut

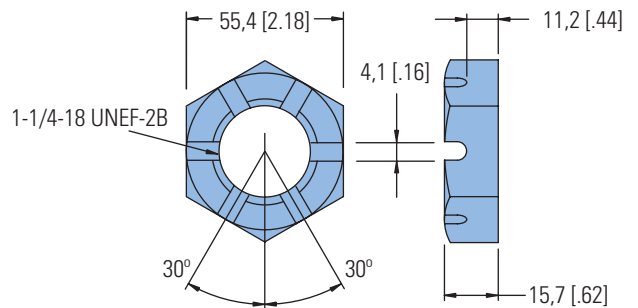



# 6000 Series

## Shaft Side Load Capacity

These curves indicate the radial load capacity on the motor shaft(s) at various locations with an external thrust load of 454 kg [1000 lb]. The maximum allowable thrust load is 908 kg [2000 lb].

**Note:**

Case pressure will increase the allowable inward thrust load and decrease the allowable outward thrust load. Case pressure will push outward on the shaft at 109 kg/7 Bar [241 lb/100 PSI].

**Each curve is based on**

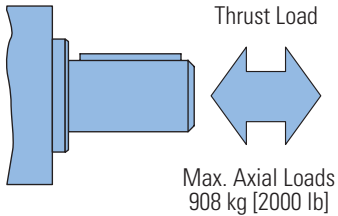

**B 10 bearing life (2000 hours of 12,000,000 shaft revolutions at 100 RPM) at rated output torque.**

To determine radial load at speeds other than 100 RPM, multiply the load values given on the bearing curve by the factors in the chart below.

RPM	Multiplication Factor
50	1.23
100	1.00
200	0.81
300	0.72
400	0.66
500	0.62
600	0.58
700	0.56
800	0.54

For 3,000,000 shaft revolutions or 500 hours—Increase these shaft loads 52%.

Standard Motor  
Straight and Splined Shafts

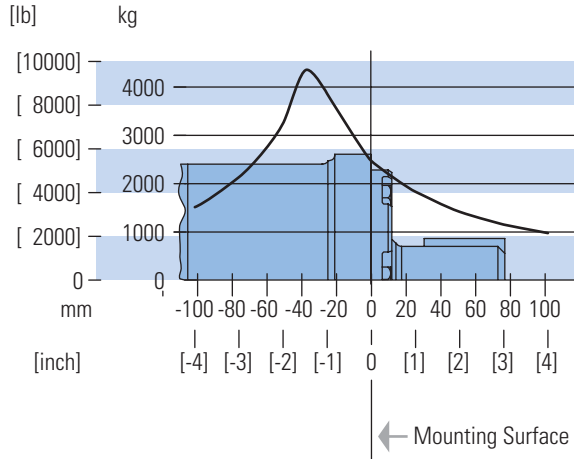

Wheel Motor Tapered Shaft

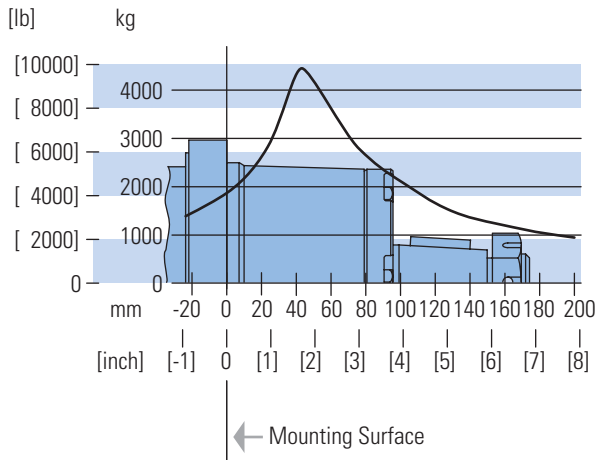

# 6000 Series

## Case Pressure and Case Port

Char-Lynn 6000 Series motors are durable and have long life as long as the recommended case pressure is not exceeded. Allowable case pressure is highest at low shaft speeds. Consequently, motor life will be shortened if case pressure exceeds these ratings (acceptability may vary with application). Determine if an external case drain is required from the case pressure seal limitation chart.

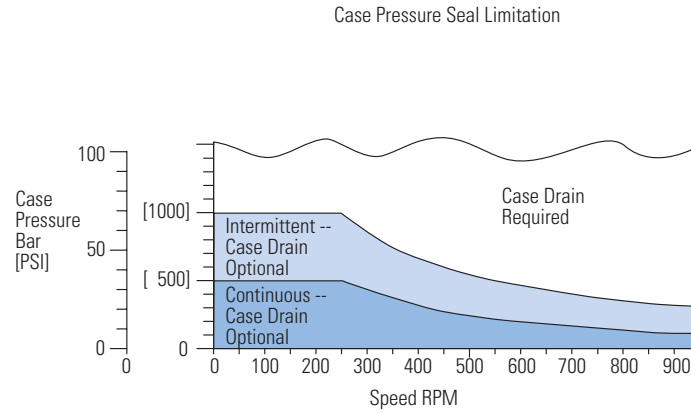

### Case Porting Advantage

**Contamination Control** — flushing the motor case.

**Cooler Motor** — exiting oil draws motor heat away.

**Extend Motor Seal Life** — maintain low case pressure with a preset restriction in the case drain line.

# 6000 Series

## Dimensions

### Ports

#### 1 5/16 -12 O-ring Ports (2) or G 1 (BSP) Ports (2)

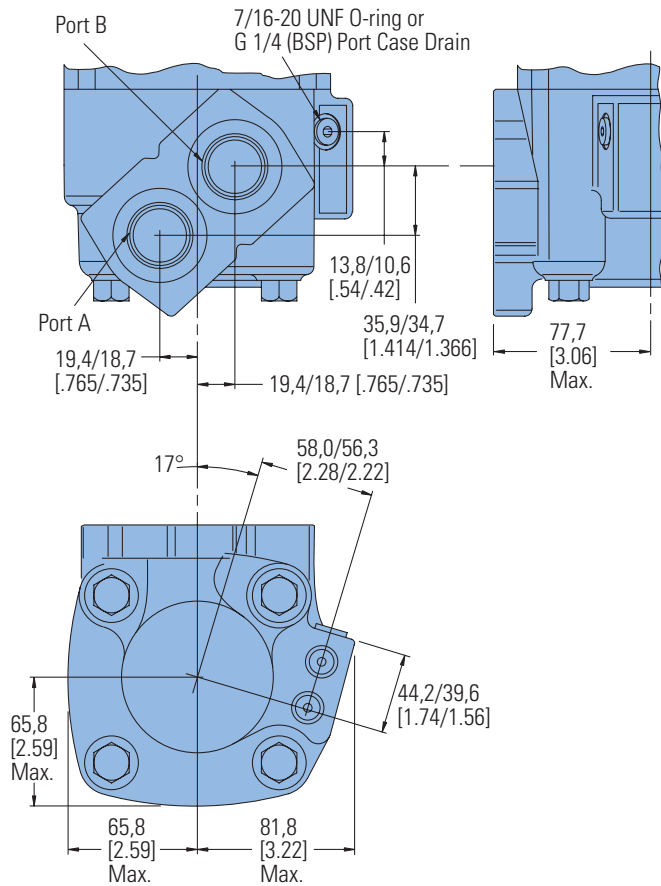

#### 4 Bolt 3/4 Inch Split Flange

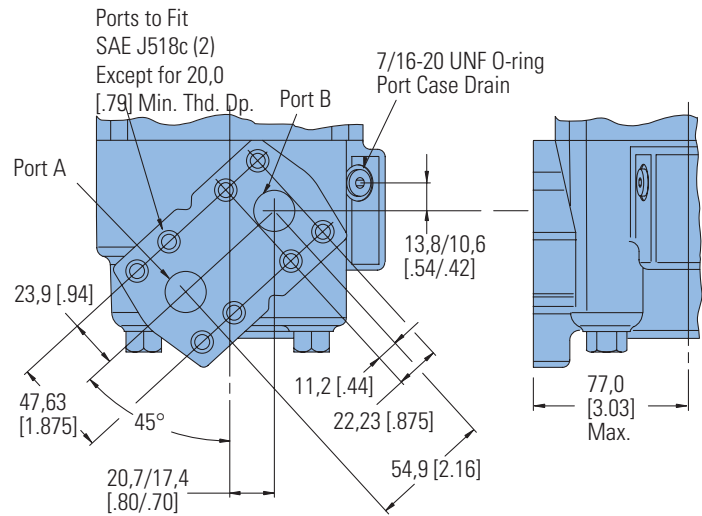

#### 1 5/16 -12 O-ring Ports (2) with Shuttle

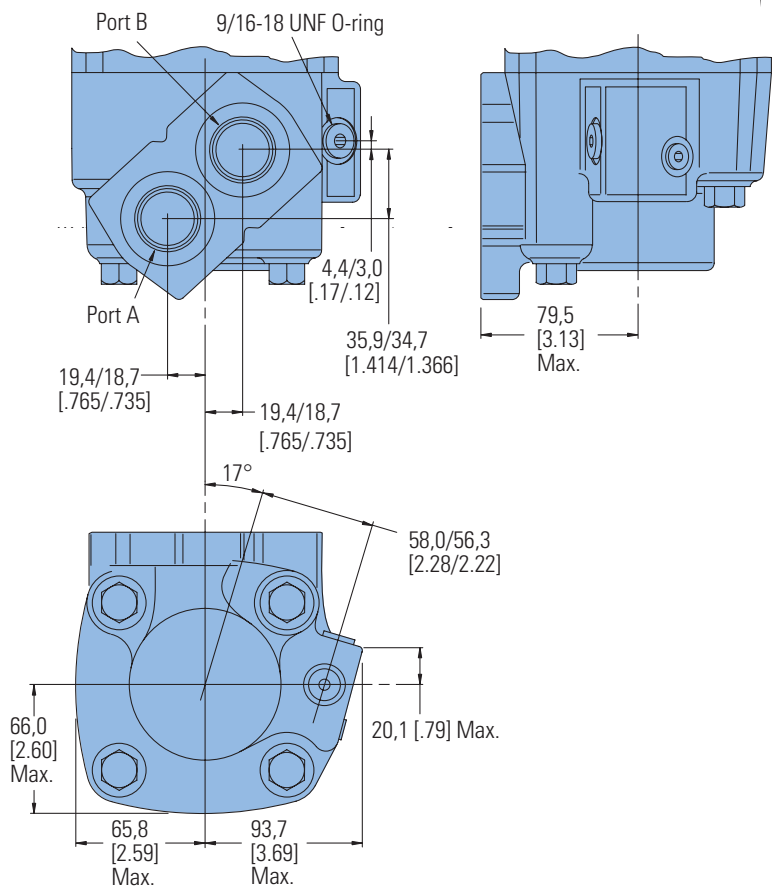

# 6000 Series

## Product Numbers

### Note:

For 6000 Series Motors with a configuration **Not Shown** in the charts above: Use model code number system on the next page to specify product in detail.

Use digit prefix — 112-, 113-, or 114 - plus four digit number from charts for complete product number— Example 114-1047.

**Orders will not be accepted without three digit prefix.**

MOUNTING	SHAFT	PORT SIZE	DISPL. cm <sup>3</sup> /r [in <sup>3</sup> /r] / PRODUCT NUMBER								
			195 [11.9]	245 [15.0]	310 [19.0]	390 [23.9]	490 [30.0]	625 [38.0]	735* [45.0]	805* [49.0]	985 [60.0]
Standard	1 1/2 inch Straight	1 5/16 O-ring	112-1064	-1065	-1066	-1067	-1068	-1107	-1145	—	-1069
	40 mm Straight	G 1 (BSP)	112-1094	-1095	-1096	-1097	-1098	—	—	—	-1099
	1 1/2 Inch 17 T Splined	1 5/16 O-ring	112-1058	-1059	-1060	-1061	-1062	-1109	1163	—	-1063
		G 1 (BSP)	112-1088	-1089	-1090	-1091	-1092	—	—	—	-1093
Wheel Motor	40 mm Straight	G 1 (BSP)	113-1082	-1083	-1084	-1085	-1086	-1100	—	—	-1087
	1-3/4 Inch Tapered	1 5/16 O-ring	113-1070	-1071	-1072	-1073	-1074	-1093	—	—	-1075
Bearingless		1 5/16 O-ring	114-1031	-1032	-1033	-1034	-1035	-1055	—	—	-1036
		G 1 (BSP)	114-1043	-1044	-1045	-1046	-1047	—	—	—	-1048

\*New release

114-1047

### Mounting Type - Standard (Code H), 4 Bolt:

- 160,0 [6.30] Pilot Dia.
- 18,01 [.709] Dia. Mounting Holes
- 200,0 [7.87] Dia. Bolt Circle

Output Shaft - Straight (Code 21)

Ports - G1 (BSP) Staggered G 1/4 Case Drain (Code C)

Paint - Low Gloss Black (Code A)

Use digit prefix — 112- plus four digit number from charts for complete product number— Example 112-1215.

**Orders will not be accepted without three digit prefix.**

MOUNTING	SHAFT	PORT SIZE	DISPL. cm <sup>3</sup> /r [in <sup>3</sup> /r] / PRODUCT NUMBER						
			310 [19.0]	390 [23.9]	490 [30.0]	625 [38.0]	735 [45.0]	805 [49.0]	985 [60.0]
Standard	50 mm Straight	G 1 (BSP)	112-1217	-1218	-1215	-1216	-1247	-1219	-1220

112-1215

# 6000 Series

## Model Code

The following 30-digit coding system has been developed to identify all of the configuration options for the 6000 Series motor. Use this model code to specify a motor with the desired features. All 30-digits of the code must be present when ordering. You may want to photocopy the matrix below to ensure that each number is entered in the correct box.

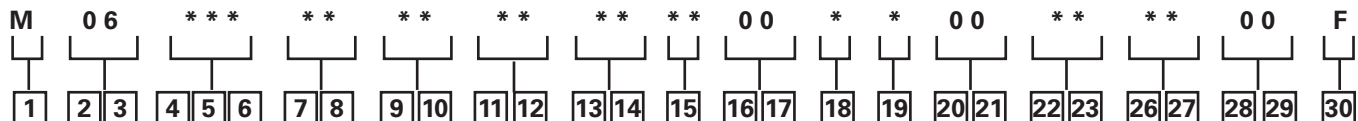

**1** Product  
M – Motor

**2, 3** Series  
06 – 6000 Series

**4, 5, 6** Displacement  
cm<sup>3</sup>/r [in<sup>3</sup>/r]

- 120 – 195.8 [11.95]
- 150 – 246.5 [15.04]
- 190 – 312.0 [19.04]
- 239 – 391.7 [23.90]
- 300 – 491.4 [29.99]
- 381 – 624.2 [38.09]
- 450 – 737.4 [45.00]
- 490 – 803.4 [49.03]
- 600 – 982.7 [59.97]

**7, 8** Mounting Type

- AA** – Bearingless, 4 Bolt: 127,0 [5.00] Pilot Dia. and 14,35 [.565] Dia. Holes 162,0 [6.38] Dia. Bolt Circle
- AB** – Standard, 4 Bolt (SAE CC): 127,0 [5.00] Pilot Dia. and 14,35 [.565] Dia. Holes on 162,0 [6.38] Dia. B.C.
- AC** – Wheel, 4 Bolt 139,7 [5.50] Pilot Dia. and 14,35 [.565] Dia. Holes on 184,2 [7.25] Dia. Bolt Circle
- AD – Standard, 4 Bolt, (SAE D): 152,4 [6.00] Pilot Dia. 15,24 [.600] Dia. Holes on 228,6 [9.00] Dia. Bolt Circle (SAE D) with O-Ring Groove to Accept ARP-163 O-Ring
- AH – Standard, 4 Bolt: 10.0 [6.30] Pilot Dia. 18,01 [.709] Dia. Holes on 200.0 [7.87] Dia. Bolt Circle.
- AL - Wheel, 4 Bolt: 160.0 [6.30] Pilot Dia. with 5.8 [.23] Pilot Length and 18.00 [.709] Dia. Holes on 200.0 [7.874] Dia. Holes on 200.0 [7.874] Dia. Bolt Circle (ISO Compatible)

**9, 10** Output Shaft Description

- 00 – None (Bearingless)
- 01 – 38,10 [1.50] Dia. Straight Shaft with .375-16 UNC-2B Thread in End, 9,52 [.375] Sq x 41,28 [1.625] Straight Key
- 02 – 44,45 [1.75] Dia. .125:1 Tapered Shaft per SAE J501 with 1.25-18 UNEF-2A Threaded Shaft End, 11,11 [.4375] Sq. x 31,8 [1.25] Straight Key
- 03 – 38,10 [1.50] Dia. Flat Root Side Fit, 17 Tooth, 12/24 DP 30 DEG. Involute Spline with .375-16 UNC-2B Thread in end 40,4 [1.59] Minimum Full Spline Length
- 04 – 40,00 [1.575] Dia. Straight Shaft with M12 x 1.75-6H Thread in End, 12W x 8H x 63L [.472W x .313H x 2.480L] Key
- 12– 49,99 [1.968] Dia. Straight Shaft with M12 x 1.75-6H Thread in End, 14W x 9H x 70L [.550W x .354H x 2.756L] Key
- 15 – 60mm Dia. 10:1 Tapered Shaft per ISO R775 with M42 x 3-6H Threaded Shaft End, 16W x 10H x 32L [1.630W x .394H x 1.26L] Key
- 16 – 53,98 [2.125] Dia. Flat Root Side Fit, 16 Tooth, 8/16 DP 30 Deg. Involute Spline with M12 x 1.75-6H Thread in End, 55,9 [2.20] Min Full Spline

**11, 12** Port Description

- AA – 1,3125-12 UN-2B SAE O-Ring Ports–Staggered Ports
- AB – SAE 19.05 [.750] Dia. 4-Bolt Split Flange - Staggered Ports
- AC – G 1 Staggered Ports
- AG – .750-16 UNF-2B SAE O-ring Ports - Staggered

**13, 14** Case Flow

- 02 – .4375-20 UNF-2B SAE O-Ring Port With Check Valve
- 03 – G 1/4 BSP Straight Thread Port with Check Valve
- 06 – .5625-18 UNF-2B SAE O-Ring Port with Shuttle Valve
- 10 – .750-16 UNF-2B SAE O-ring Ports, External Lubrication Circuit Requires Case Drain must be Connected, .063 Shuttle Flow Orifice

**15** Low Pressure Relief

- 0 – None
- A – Set at 4.5 [65 lbf/in<sup>2</sup>]
- B – Set at 15.2 [220 lbf/in<sup>2</sup>]

**16, 17** Pressure/Flow Option

- 00 – None

**18** Geroler Option

- 0 – Standard
- 2 – Tight Fitting

**19** Seal Option

- 0 – Standard
- 00 – Standard Seals
- 02 – Seal Guard
- 03 – Viton Seals
- 04 – Viton Shaft Seal
- 11 – High pressure shaft seal, slinger seal
- 19 – Extreme duty seal guard

**20, 21** Accessories

- 00 – None

**22, 23** Special Features (Hardware)

- 00 – None
- 01 – Non-Masked Nameplate
- 02 – Non-Masked Nameplate, Low Noise Valve Plate
- 03 – Low Noise Valve Plate

**24, 25** Special Features (Assembly)

- 00 – None
- AA – Reverse Rotation

**26, 27** Paint/Packaging

- 00 – No Paint, Individual Box
- AA – Low Gloss Black Primer
- AD – No Paint, Bulk Box Option
- AE – Low Gloss Black Primer, Bulk Box Option

**28, 29** Customer ID

- 00 – None

**30** Design Code

- F – Sixth

Feature in bold are preferred and allow for shorter lead time

# 10,000 Series

## Highlights

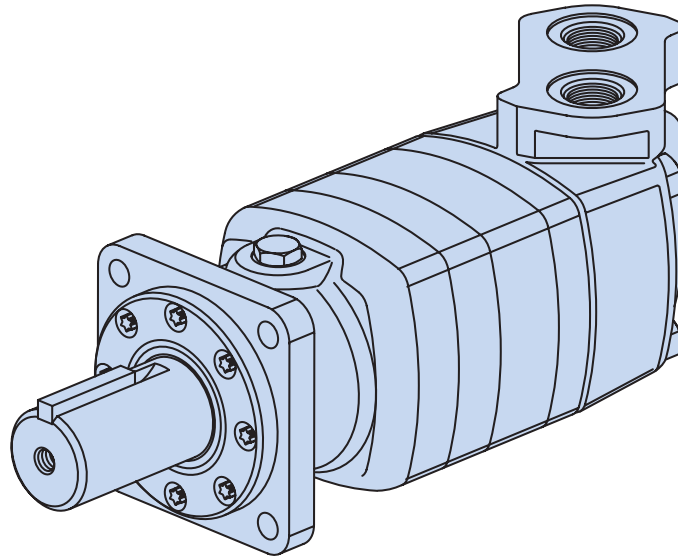

### Features

- High torque and flow
- Many options like 2 speed and speed sensors make this motor “smart”
- Low pressure loss even in higher flows

### Benefits

- High power density for demanding mobile and industrial applications
- Many options to draw from

### Applications

- Boring
- Industrial
- Metal Forming
- Port Equipment
- Saw Mill

### Description

This is the biggest disc valve motor of our line with up to 45 GPM and 24,000 in-lb of torque in continuous mode, this motor is powerful and yet provides good efficiency.

### Specifications

Geroler Element	4 Displacements
Flow l/min [GPM]	170 [45] Continuous**
	265 [70] Intermittent*
Speed RPM	501 Cont.**
	784 Inter.*
Pressure bar [PSI]	200 [3000] Cont.**
	270 [4000] Inter.*
Torque Nm [lb-in]	2700 [23910] Cont.**
	3440 [30460] Inter.*

\*\* Continuous—(Cont.) Continuous rating, motor may be run continuously at these ratings.

\* Intermittent—(Inter.) Intermittent operation, 10% of every minute.



Boring



Metal Forming



Port Equipment

# 10,000 Series

## Specifications

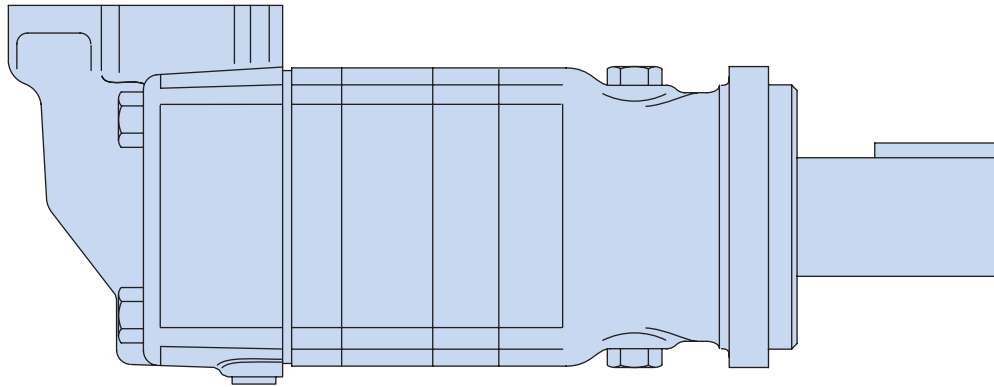

### 10,000 SERIES MOTORS

Displ. cm <sup>3</sup> /r [in <sup>3</sup> /r]		345 [21.0]	480 [29.3]	665 [40.6]	940 [57.4]
Max. Speed (RPM) @ Flow	Continuous	501	354	254	179
	Intermittent	784	552	396	279
Flow l/min [GPM]	Continuous	170 [45]	170 [45]	170 [45]	170 [45]
	Intermittent	265 [70]	265 [70]	265 [70]	265 [70]
Torque* Nm [lb-in]	Continuous	1040 [ 9220]	1475 [13050]	2085 [18450]	2700 [23910]
	Intermittent	1390 [12310]	1965 [17410]	2610 [23080]	3440 [30460]
Pressure Δ bar [Δ PSI]	Continuous	205 [3000]	205 [3000]	205 [3000]	190 [2750]
	Intermittent	275 [4000]	275 [4000]	260 [3750]	240 [3500]
	Peak	275 [4000]	275 [4000]	275 [4000]	260 [3750]
Weight kg [lb]	Standard or Wheel Mount	43,5 [96.0]	45,4 [100.0]	46,3 [100.0]	47,2 [104.0]
	Bearingless	31,3 [69.0]	33,1 [73.0]	33,1 [73.0]	34,9 [77.0]

\*See shaft torque ratings for limitations..

#### Note:

To assure best motor life, run motor for approximately one hour at 30% of rated pressure before application to full load. Be sure motor is filled with fluid prior to any load applications.

#### Maximum Inlet Pressure:

275 bar [4000 PSI]  
Do not exceed Δ pressure rating (see chart above).

#### Maximum Return Pressure:

275 bar [4000 PSI] with case drain line installed.  
Do not exceed Δ pressure rating (see chart above).

#### Maximum Case Pressure:

20 bar [300 PSI]

#### Δ bar [Δ PSI] :

The true pressure difference between inlet port and outlet port

#### Continuous Rating:

Motor may be run continuously at these ratings

#### Intermittent Operation:

10% of every minute

#### Peak Operation:

1% of every minute

#### Recommended Fluids:

Premium quality, anti-wear type hydraulic oil with a viscosity of not less than 70 SUS at operating temperature.

#### Recommended System Operating Temp.:

-34°C to 82°C [-30°F to 180°F]

#### Recommended Filtration:

per ISO Cleanliness Code, 4406: 20/18/13

# 10,000 Series

## Performance Data

Motors run with high efficiency in all areas designated with a number for torque and speed. For best motor life select a motor to run with a torque and speed range shown in the light shaded area.

Performance data is typical at 120 SUS. Actual data may vary slightly from unit to unit in production.

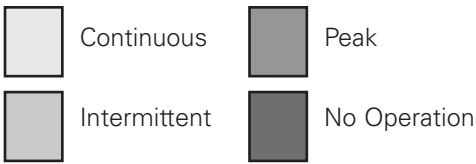

**480cm<sup>3</sup>/r [29.3 in<sup>3</sup>/r]**  
**ΔPressure Bar [PSI]**

	[250] 15	[500] 35	[1000] 70	[1500] 105	[2000] 140	[2500] 170	[3000] 205	[3500] 240	[4000] 275
[1] 3.8	[760] 85 6	[1540] 175 5	[3120] 355 4	[4640] 525 2					
[2] 7.5	[1040] 120 15	[2140] 240 13	[4320] 490 11	[6500] 735 8	[8690] 980 5	[10870] 1230 2			
[4] 15	[1040] 120 31	[2130] 240 29	[4310] 485 27	[6490] 735 24	[8680] 980 21	[10860] 1225 18	[13050] 1475 16	[15230] 1720 13	[17410] 1965 10
[8] 30	[1020] 115 62	[2110] 240 61	[4290] 485 58	[6480] 730 55	[8660] 980 53	[10840] 1225 50	[13030] 1470 47	[15210] 1720 44	[17390] 1965 42
[12] 45	[990] 110 94	[2080] 235 93	[4270] 480 90	[6450] 730 87	[8630] 975 84	[10820] 1220 81	[13000] 1470 78	[15180] 1715 75	[17370] 1965 73
[16] 61	[960] 110 125	[2060] 235 124	[4240] 480 122	[6420] 725 119	[8600] 970 116	[10790] 1220 113	[12970] 1465 110	[15150] 1710 107	[17340] 1960 104
[20] 76	[930] 105 157	[2020] 230 156	[4200] 475 154	[6390] 720 150	[8570] 970 147	[10750] 1215 144	[12940] 1460 141	[15120] 1710 138	[17300] 1955 135
[24] 91	[890] 100 189	[1980] 225 188	[4170] 470 185	[6350] 715 182	[8530] 965 179	[10720] 1210 175	[12900] 1460 172	[15080] 1705 169	
[28] 106	[850] 95 221	[1940] 220 220	[4130] 465 217	[6310] 715 214	[8490] 960 210	[10680] 1205 207	[12860] 1455 203	[15040] 1700 200	
[32] 121	[810] 90 252	[1900] 215 251	[4080] 460 249	[6270] 710 245	[8450] 955 242	[10630] 1200 238	[12820] 1450 235	[15000] 1695 231	
[36] 136	[760] 85 282	[1850] 210 281	[4040] 455 280	[6220] 705 277	[8400] 950 273	[10590] 1195 270	[12770] 1445 266		
[40] 151	[710] 80 318	[1800] 205 316	[3990] 450 312	[6170] 695 308	[8350] 945 305	[10540] 1190 301	[12720] 1440 297		
[45] 170	[647] 75 354	[1740] 195 353	[3920] 445 351	[6110] 690 348	[8290] 935 344	[10470] 1185 340	[12660] 1430 336		
[60] 227	[430] 50 474	[1520] 170 473	[3710] 420 471	[5890] 665 467	[8070] 910 462	[10260] 1160 458	[12440] 1405 454		
[70] 265		[1360] 155 552	[3540] 400 550	[5730] 645 546	[7910] 895 541	[10100] 1140 536	[12280] 1385 532		

**345cm<sup>3</sup>/r [21.0 in<sup>3</sup>/r]**  
**ΔPressure Bar [PSI]**

	[250] 15	[500] 35	[1000] 70	[1500] 105	[2000] 140	[2500] 170	[3000] 205	[3500] 240	[4000] 275
[1] 3.8	[600] 70 3	[1310] 150 1							
[2] 7.5	[740] 85 21	[1510] 170 19	[3050] 345 15	[4600] 520 11	[6140] 695 8	[7680] 865 4			
[4] 15	[730] 80 43	[1500] 170 41	[3040] 345 37	[4590] 520 33	[6140] 695 30	[7680] 870 26	[9220] 1040 22	[10770] 1215 18	[12310] 1390 14
[8] 30	[720] 80 87	[1490] 170 86	[3030] 340 82	[4580] 515 78	[6120] 690 74	[7670] 865 70	[9210] 1040 66	[10750] 1215 62	[12300] 1390 58
[12] 45	[700] 80 131	[1470] 165 130	[3020] 340 127	[4560] 515 123	[6100] 690 118	[7650] 865 114	[9190] 1040 110	[10740] 1215 106	[12280] 1385 102
[16] 61	[680] 75 176	[1450] 165 175	[3000] 340 172	[4540] 515 167	[6080] 685 163	[7630] 860 158	[9170] 1035 154	[10720] 1210 149	[12260] 1385 145
[20] 76	[660] 75 221	[1430] 160 220	[2970] 335 217	[4520] 510 212	[6060] 685 207	[7600] 860 202	[9150] 1035 198	[10690] 1210 193	[12230] 1380 189
[24] 91	[630] 70 266	[1400] 160 265	[2950] 335 261	[4490] 505 256	[6030] 680 252	[7580] 855 246	[9120] 1030 242	[10660] 1205 237	[12210] 1380 232
[28] 106	[600] 70 310	[1370] 155 309	[2920] 330 306	[4460] 505 301	[6000] 680 296	[7550] 855 291	[9090] 1025 286	[10640] 1200 280	[12180] 1375 275
[32] 121	[570] 65 356	[1340] 150 355	[2890] 325 351	[4430] 500 346	[5970] 675 340	[7520] 850 335	[9060] 1025 329	[10610] 1200 324	[12150] 1370 319
[36] 136	[540] 60 400	[1310] 150 399	[2850] 320 396	[4400] 495 390	[5940] 670 384	[7480] 845 379	[9030] 1020 373	[10570] 1195 368	[12120] 1370 362
[40] 151	[500] 55 445	[1270] 145 444	[2820] 320 441	[4360] 495 435	[5910] 670 429	[7450] 845 423	[8990] 1015 417	[10540] 1190 412	
[45] 170	[460] 50 501	[1220] 140 500	[2760] 310 498	[4300] 485 492	[5840] 660 486	[7380] 835 480	[8910] 1005 473	[10450] 1180 467	
[60] 227		[1080] 130 668	[2620] 295 665	[4160] 470 658	[5710] 645 651	[7250] 820 644	[8800] 995 637		
[70] 265		[960] 110 784	[2510] 285 777	[4050] 460 769	[5590] 630 761	[7140] 805 754	[8680] 980 746		





# 10,000 Series

## Performance Data

Motors run with high efficiency in all areas designated with a number for torque and speed. For best motor life select a motor to run with a torque and speed range shown in the light shaded area.

Performance data is typical at 120 SUS. Actual data may vary slightly from unit to unit in production.

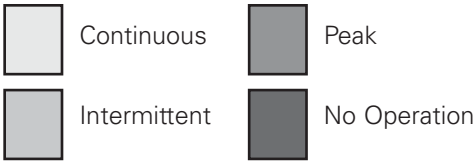

665cm<sup>3</sup>/r [40.6 in<sup>3</sup>/r]

ΔPressure Bar [PSI]

	[250] 15	[500] 35	[750] 50	[1000] 70	[1250] 85	[1500] 105	[1750] 120	[2000] 140	[2250] 155	[2500] 170	[2750] 190	[3000] 205	[3250] 225	[3500] 240	[3750] 260
[1] 3.8	[1470] 165 4	[3010] 340 3	[4550] 515 3	[6100] 690 2	[7630] 860 1										
[2] 7.5	[1480] 165 10	[3020] 340 9	[4560] 515 8	[6110] 690 7	[7650] 865 7	[9200] 1040 6	[10740] 1215 5	[12280] 1385 4	[13830] 1565 3	[15370] 1735 2	[16910] 1910 1				
[4] 15	[1470] 165 22	[3010] 340 21	[4550] 515 20	[6100] 690 19	[7640] 865 18	[9190] 1040 17	[10730] 1210 16	[12270] 1385 15	[13820] 1560 14	[15360] 1735 13	[16900] 1910 12	[18450] 2085 11	[19990] 2260 10	[21540] 2435 9	[23080] 2610 8
[8] 30	[1440] 165 44	[2980] 335 43	[4530] 510 42	[6070] 685 41	[7610] 860 40	[9160] 1035 39	[10700] 1210 38	[12250] 1385 37	[13790] 1560 36	[15330] 1730 35	[16880] 1905 34	[18420] 2080 33	[19960] 2255 32	[21510] 2430 31	[23050] 2605 30
[12] 45	[1400] 160 67	[2950] 335 66	[4490] 505 65	[6040] 680 64	[7580] 855 63	[9120] 1030 62	[10670] 1205 61	[12210] 1380 60	[13750] 1555 59	[15300] 1730 58	[16840] 1905 57	[18380] 2075 56	[19930] 2250 55	[21470] 2425 54	[23020] 2600 53
[16] 61	[1360] 155 89	[2910] 330 88	[4450] 505 87	[5990] 675 86	[7530] 850 85	[9080] 1025 84	[10620] 1200 83	[12170] 1375 82	[13710] 1550 81	[15260] 1725 80	[16800] 1900 79	[18340] 2070 78	[19890] 2245 77	[21440] 2420 76	
[20] 76	[1310] 150 112	[2860] 375 111	[4400] 495 110	[5940] 670 109	[7490] 845 108	[9030] 1020 107	[10580] 1195 106	[12120] 1370 105	[13660] 1545 104	[15210] 1720 103	[16750] 1890 102	[18300] 2070 101	[19840] 2240 99		
[24] 91	[1260] 140 135	[2800] 315 134	[4350] 490 132	[5890] 665 131	[7440] 840 130	[8980] 1015 129	[10520] 1190 128	[12070] 1365 127	[13610] 1540 126	[15150] 1710 125	[16700] 1885 123	[18240] 2060 122			
[28] 106	[1200] 135 157	[2750] 310 156	[4290] 485 155	[5840] 660 154	[7380] 835 153	[8920] 1010 151	[10470] 1185 150	[12010] 1355 149	[13550] 1530 148	[15100] 1705 147	[16640] 1880 146				
[32] 121	[1140] 130 180	[2690] 305 179	[4230] 480 177	[5770] 650 176	[7320] 825 175	[8860] 1000 174	[10400] 1175 173	[11950] 1350 172	[13490] 1525 170	[15040] 1700 169	[16580] 1875 168				
[36] 136	[1080] 120 202	[2620] 295 201	[4160] 470 200	[5710] 645 199	[7250] 820 198	[8800] 995 196	[10340] 1170 195	[11880] 1340 194	[13430] 1515 193	[14970] 1690 191	[16510] 1865 190				
[40] 151	[1010] 115 225	[2550] 290 224	[4100] 465 222	[5640] 635 221	[7180] 810 220	[8730] 985 219	[10270] 1160 217	[11810] 1355 216	[13360] 1510 215	[14900] 1685 214	[16440] 1855 212				
[45] 170	[920] 105 254	[2460] 280 252	[4000] 450 251	[5550] 625 249	[7090] 800 248	[8630] 975 247	[10180] 1150 245	[11720] 1325 244	[13260] 1500 243	[14810] 1675 242					
[60] 227	[610] 70 338	[2150] 245 336	[3700] 420 335	[5240] 590 334	[6780] 765 332	[8330] 940 331	[9870] 1115 329	[11420] 1290 328	[12960] 1465 327						
[70] 265	[380] 45 396	[1930] 220 393	[3470] 390 391	[5010] 565 390	[6560] 740 388	[8100] 915 387	[9640] 1090 385	[11190] 1265 384							



940cm<sup>3</sup>/r [57.4 in<sup>3</sup>/r]

ΔPressure Bar [PSI]

	[250] 15	[500] 35	[750] 50	[1000] 70	[1250] 85	[1500] 105	[1750] 120	[2000] 140	[2250] 155	[2500] 170	[2750] 190	[3000] 205	[3250] 225	[3500] 240
[1] 3.8	[2080] 235 3	[4260] 480 2	[6440] 730 1											
[2] 7.5	[2090] 235 7	[4270] 480 6	[6450] 730 5	[8640] 975 5	[10820] 1220 4	[13000] 1470 3	[15190] 1715 2	[17370] 1965 1						
[4] 15	[2080] 235 15	[4260] 480 14	[6440] 730 13	[8620] 975 13	[10810] 1220 12	[12990] 1470 11	[15170] 1715 10	[17360] 1960 9	[19540] 2210 8	[21720] 2455 7	[23910] 2700 6	[26090] 2950 5	[28270] 3195 4	[30460] 3440 4
[8] 30	[2040] 230 31	[4220] 475 30	[6400] 725 29	[8590] 970 28	[10770] 1215 28	[12950] 1465 27	[15140] 1710 26	[17320] 1955 25	[19500] 2200 24	[21690] 2450 23	[23870] 2695 22			
[12] 45	[1990] 225 47	[4170] 470 46	[6350] 715 45	[8540] 965 44	[10720] 1210 43	[12900] 1460 43	[15090] 1705 42	[17270] 1950 41	[19450] 2200 40	[21640] 2445 39				
[16] 61	[1930] 220 63	[4110] 465 62	[6290] 710 61	[8480] 960 60	[10660] 1205 59	[12840] 1450 58	[15030] 1700 57	[17210] 1945 56	[19390] 2190 55					
[20] 76	[1860] 210 79	[4040] 455 78	[6220] 705 77	[8410] 950 76	[10590] 1195 75	[12770] 1445 74	[14960] 1690 73	[17140] 1935 72	[19320] 2185 72					
[24] 91	[1780] 200 95	[3970] 450 94	[6150] 695 93	[8330] 940 92	[10520] 1190 91	[12700] 1435 90	[14880] 1680 89	[17070] 1930 88						
[28] 106	[1700] 190 111	[3890] 440 110	[6070] 685 109	[8250] 930 108	[10440] 1180 107	[12620] 1425 106	[14800] 1675 105	[16990] 1920 104						
[32] 121	[1620] 185 127	[3800] 430 126	[5980] 675 125	[8160] 920 124	[10350] 1170 123	[12530] 1415 122	[14720] 1665 121							
[36] 136	[1520] 170 143	[3710] 420 142	[5890] 665 141	[8070] 910 140	[10260] 1160 139	[12440] 1405 138	[14620] 1650 137							
[40] 151	[1420] 160 159	[3610] 410 158	[5790] 655 157	[7970] 900 156	[10160] 1150 155	[12340] 1395 154	[14520] 1640 153							
[45] 170	[1290] 145 179	[3480] 395 178	[5660] 640 177	[7840] 885 176	[10020] 1130 174	[12210] 1380 173	[14400] 1625 173							
[60] 227	[860] 95 239	[3040] 345 238	[5230] 590 236	[7410] 835 235	[9600] 1085 234	[11780] 1330 233								
[70] 265	[540] 60 279	[2720] 305 278	[4910] 555 276	[7090] 800 275	[9270] 1045 274	[11460] 1295 273								

# 10,000 Series

## Dimensions

### Ports

- 1 5/16 -12 UN-2B SAE O-ring Staggered Ports (2)
- 9/16 -18 UNF-2B SAE O-ring Case Drain Port (1) or
- 4 Bolt 1 1/4 inch Split Flange Ports (2)
- 9/16 -18 UNF-2B SAE O-ring Case Drain Port (1)

### Standard Rotation Viewed from Shaft End

- Port A Pressurized — CW
- Port B Pressurized — CCW

## Standard Mount

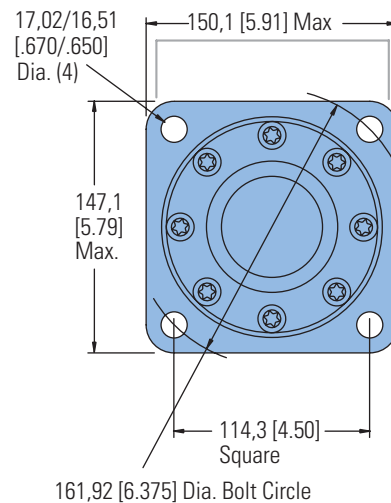
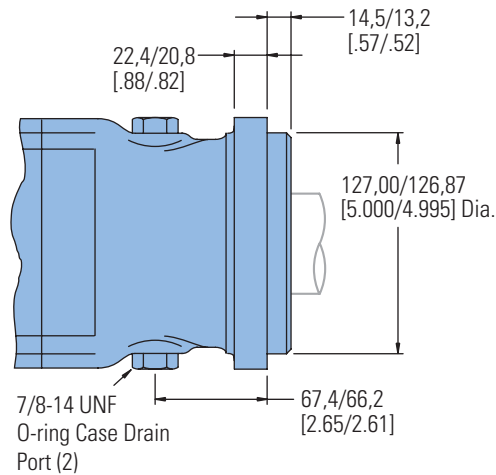
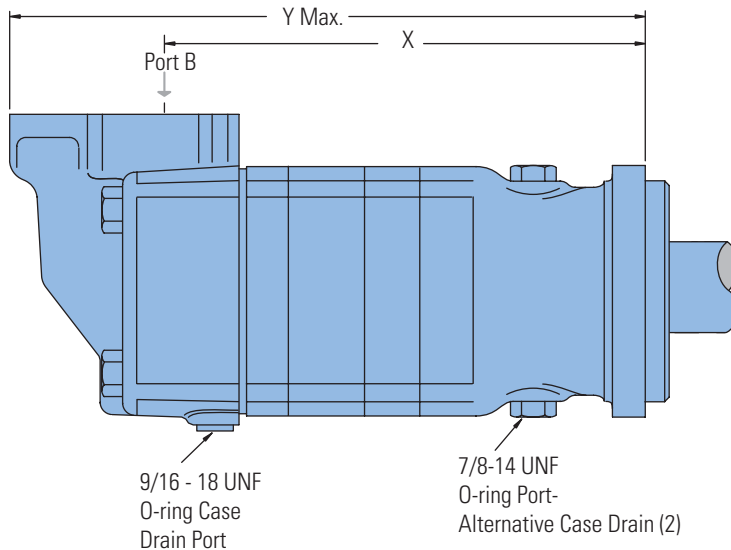

### STANDARD MOUNT MOTOR DIMENSIONS

Displacement cm <sup>3</sup> /r [in <sup>3</sup> /r]	X mm [inch]	Y mm [inch]
345 [21.0]	282,4 [11.12]	380,7 [14.99]
480 [29.2]	295,1 [11.62]	393,4 [15.49]
665 [40.6]	295,1 [11.62]	393,4 [15.49]
940 [57.4]	313,4 [12.34]	411,7 [16.21]

# 10,000 Series

## Dimensions

### Ports

- 1 5/16 -12 UN-2B SAE O-ring Staggered Ports (2)
- 9/16 -18 UNF-2B SAE O-ring Case Drain Port (1) or
- 4 Bolt 1 1/4 inch Split Flange Ports (2)
- 9/16 -18 UNF-2B SAE O-ring Case Drain Port (1)

### Standard Rotation Viewed from Shaft End

- Port A Pressurized — CW
- Port B Pressurized — CCW

## Wheel Mount

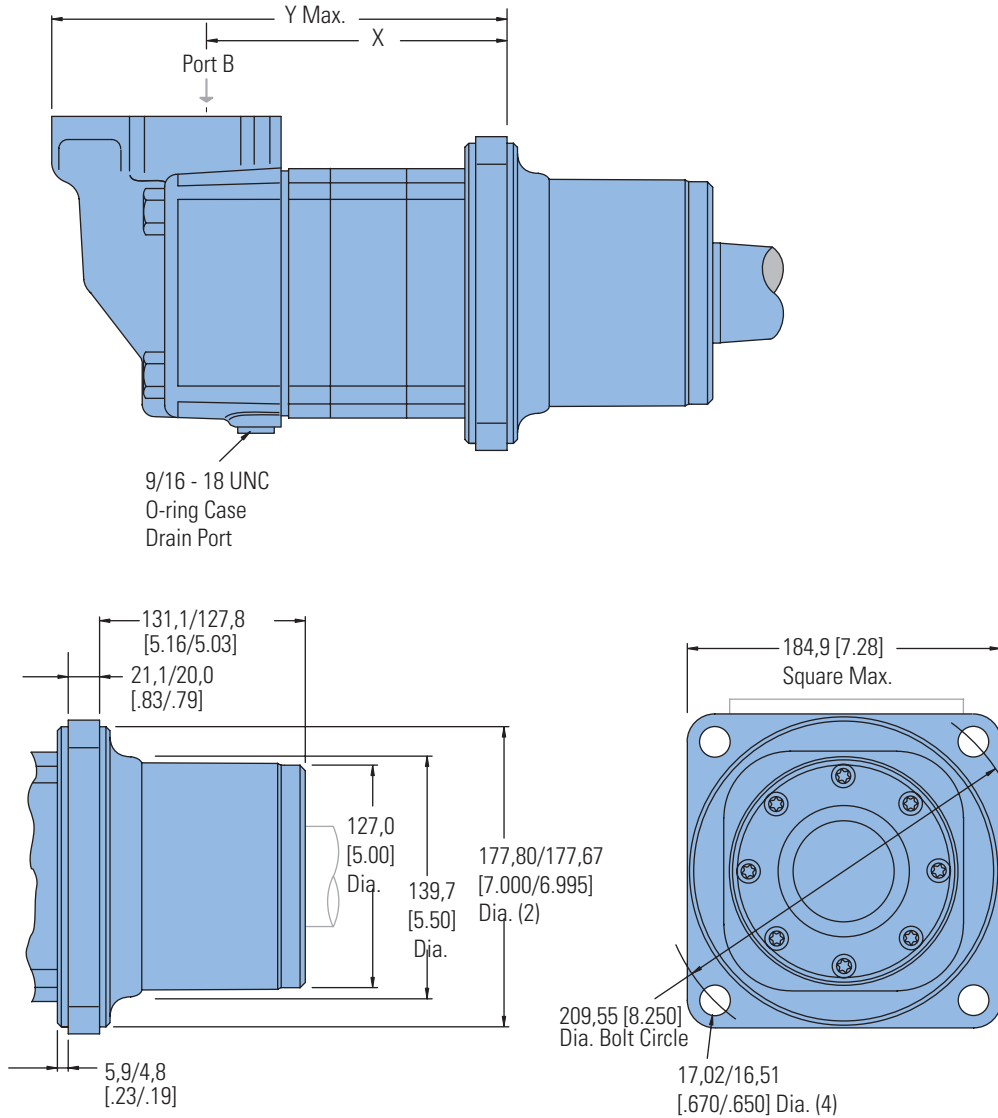

### WHEEL MOUNT MOTOR DIMENSIONS

Displacement cm <sup>3</sup> /r [in <sup>3</sup> /r]	X mm [inch]	Y mm [inch]
345 [21.0]	166,9 [6.57]	265,9 [10.47]
480 [29.2]	179,6 [7.07]	278,6 [10.97]
665 [40.6]	179,6 [7.07]	278,6 [10.97]
940 [57.4]	197,8 [7.79]	297,2 [11.70]

# 10,000 Series

Dimensions

Bearingless

## Ports

- 1 5/16 -12 UN-2B SAE O-ring Staggered Ports (2)
- 9/16 -18 UNF-2B SAE O-ring Case Drain Port (1) or
- 4 Bolt 1 1/4 inch Split Flange Ports (2)
- 9/16 -18 UNF-2B SAE O-ring Case Drain Port (1)

## Standard Rotation Viewed from Shaft End

- Port A Pressurized — CW
- Port B Pressurized — CCW

## Bearingless

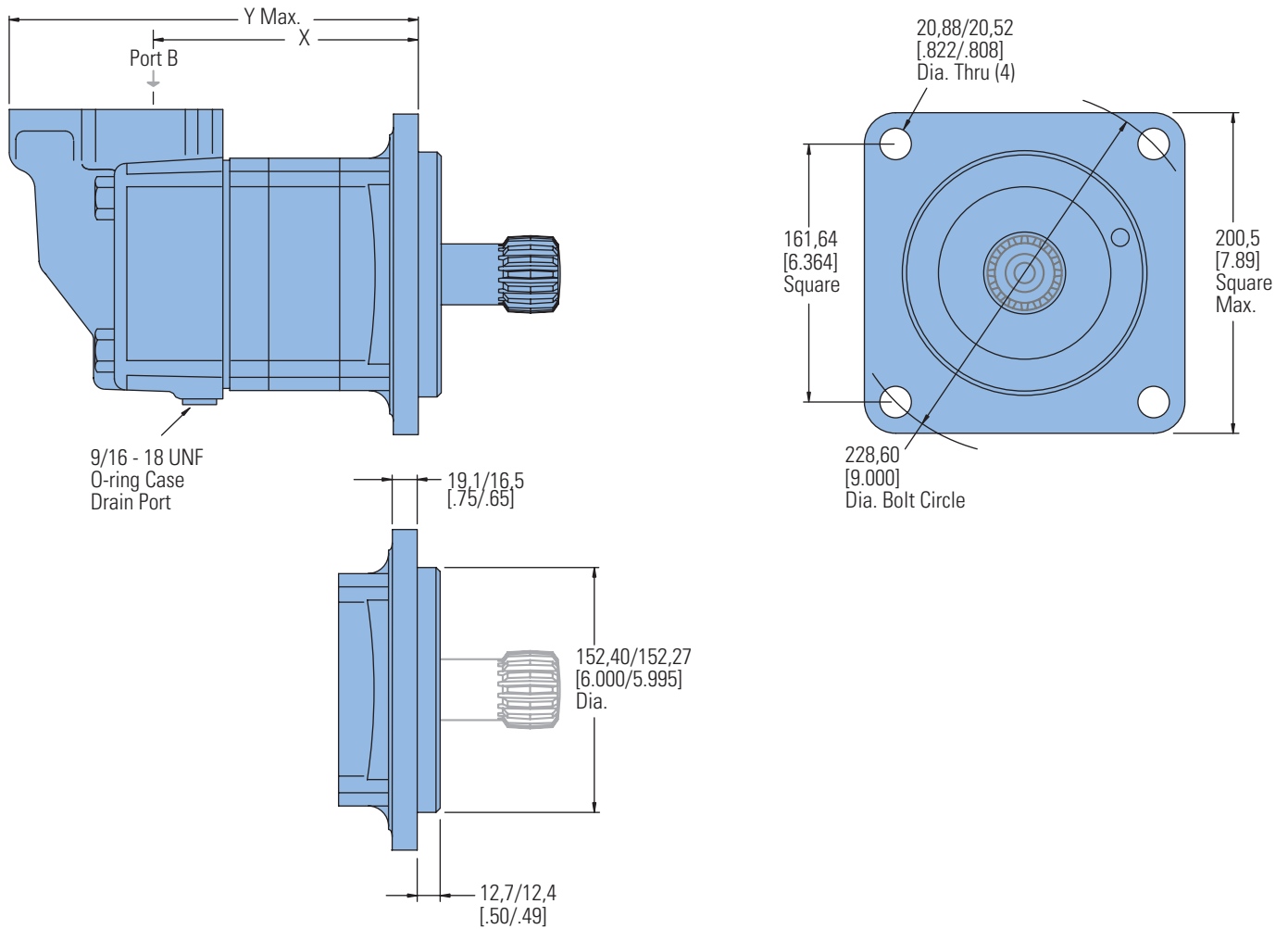

9/16 - 18 UNF  
O-ring Case  
Drain Port

## Mating Coupling Blank

Dimension D mm [inch]  
Eaton Part No.

13280-001	133,6/128,5 [5.26/5.06]
13280-002	156,0/150,9 [6.14/5.94]

For 10,000 bearingless motor application information, contact your Eaton representative (mating coupling blanks available from Eaton Hydraulics).

## Note:

After machining blank, part must be hardened per Eaton specification.

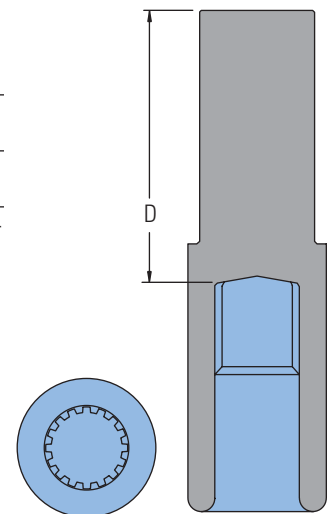

C-6

## BEARINGLESS MOTOR DIMENSIONS

Displacement cm <sup>3</sup> /r [in <sup>3</sup> /r]	X mm [inch]	Y mm [inch]
345 [21.0]	158,0 [6.22]	256.3 [10.09]
480 [29.2]	170,7 [6.72]	269,0 [10.59]
665 [40.6]	170,7 [6.72]	269,0 [10.59]
940 [57.4]	189,0 [7.44]	287,5 [11.32]

# 10,000 Series

## Installation Information

### Bearingless

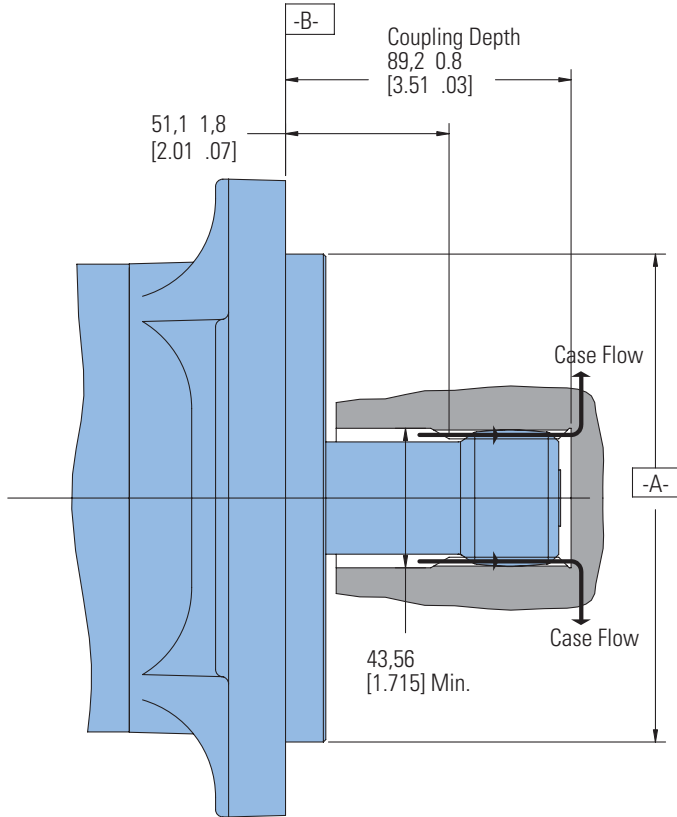

1 Internal spline in mating part to be as follows: Material to be ASTM A304, 8620H. Carbonize to a hardness of 60-64 HRC with case depth (to 50HRC) of 0,076 - 1,02 [.030 - .040] (dimensions apply after heat treat).

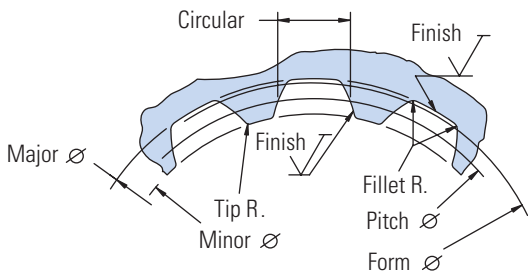

Spline Pitch.....	10/20
Pressure Angle.....	.30°
Number of teeth.....	16
Class of Fit.....	Ref. 5
Type of Fit.....	Side
Pitch Diameter .....	Ref. 40,640000 [1.6000000] $\text{Ⓢ} 0,25 [0.010]   D$
Base Diameter.....	Ref. 35,195272 [1.3856406]
Major Diameter.....	43,56 [1.715] Max. 43,18 [1.700] Min.
Min. Minor Diameter.....	36,83 - 37,08 [1.450 - 1.460]
Form Diameter, Min.....	42,47 [1.672]
Fillet Radius.....	0,64 - 0,76 [0.025 - .030]
Tip Radius.....	0,25 - 0,51 [0.010 - .020]
Finish.....	1,6 (63)
Involute Profile Variation.....	+0,000 -0,028 [+0.0000 -0.0011]
Total Index Variation .....	0,041 [0.0016]
Lead Variation .....	0,013 [0.0005]
Circular Space Width:	
Maximum Actual.....	4,105 [0.1616]
Minimum Effective .....	3,995 [0.1573]
Maximum Effective .....	Ref. 4,056 [0.1597]
Minimum Actual .....	Ref. 4,018 [0.1582]
Dimension Between Two Pins.....	Ref. 26,929 - 27,084 [1.0602 - 1.0663]
Pin Diameter .....	Ref. 34,272 - 34,450 [1.3493 - 1.3563]
	Wide Flat for Root Clearance

# 10,000 Series

## Dimensions

### Shafts

#### 2 1/4 Inch Straight

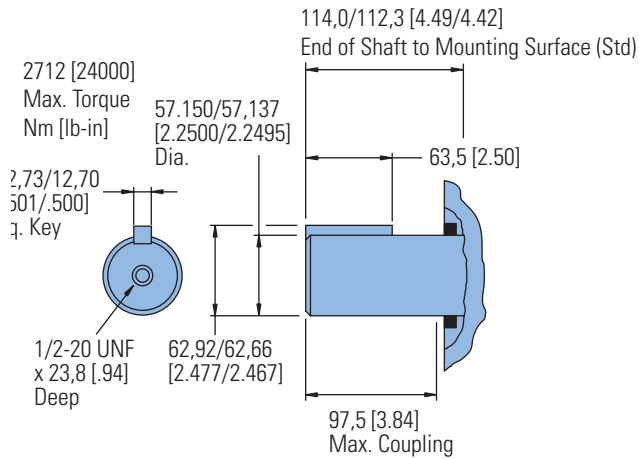

#### 2 1/4 Inch Tapered

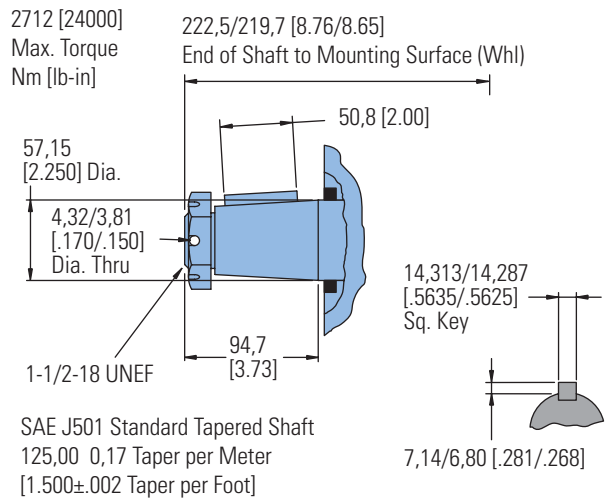

#### 2 1/8 Inch 16 Tooth Splined

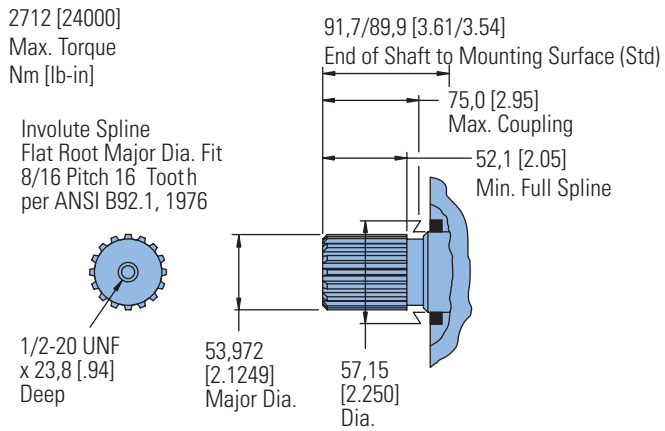

#### Tapered Shaft Hub Data

Recommended Torque:  
(1150 Nm [850 lb-ft] Dry)  
( 880 Nm [650 lb-ft] Lub)  
Plus Torque required to  
align the slotted nut with  
the Shaft Crosshole.

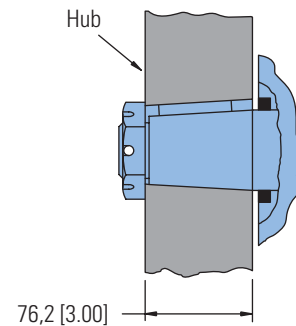

#### Slotted Hexagon Nut

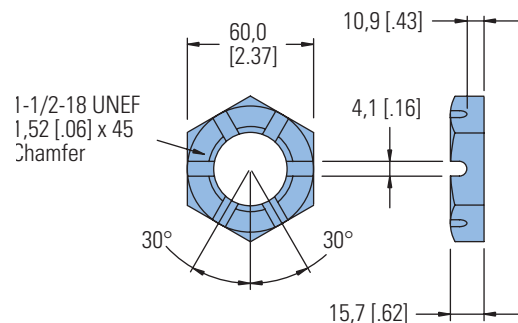

# 10,000 Series

## Side Shaft Load Capacity

These curves indicate the radial load capacity on the motor shaft at various locations with an external thrust load of 454 kg [1000 lb]. The maximum allowable thrust load is 908 kg [2000 lb].

**Note:**

Case pressure will increase the allowable inward thrust load and decrease the allowable outward thrust load. Case pressure will push outward on the shaft at 200 kg/7 Bar [441 lb/100 PSI].

**Each curve is based on**

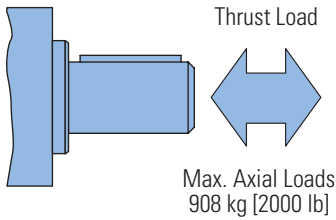

**B 10 bearing life (2000 hours of 12,000,000 shaft revolutions at 100 RPM) at rated output torque.**

To determine radial load at speeds other than 100 RPM, multiply the load values given on the bearing curve by the factors in the chart below.

RPM	Multiplication Factor
50	1.23
100	1.00
200	0.81
300	0.72
400	0.66
500	0.62
600	0.58
700	0.56
800	0.54

For 3,000,000 shaft revolutions or 500 hours—Increase these shaft loads 52%.

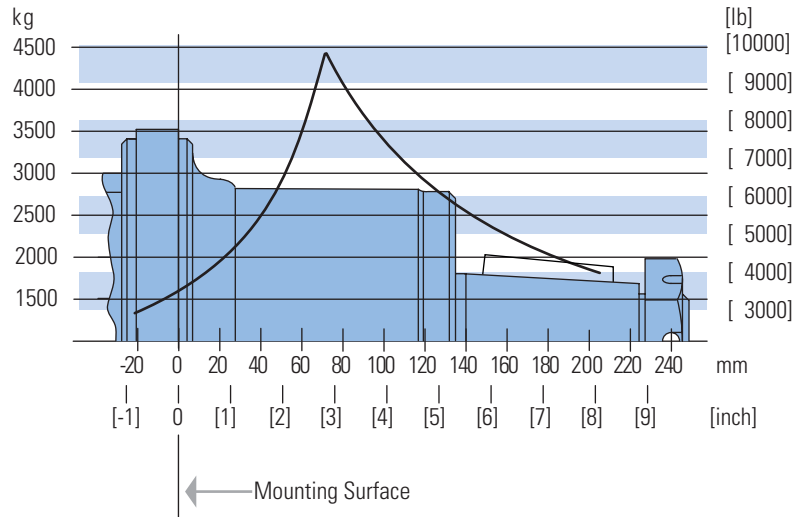
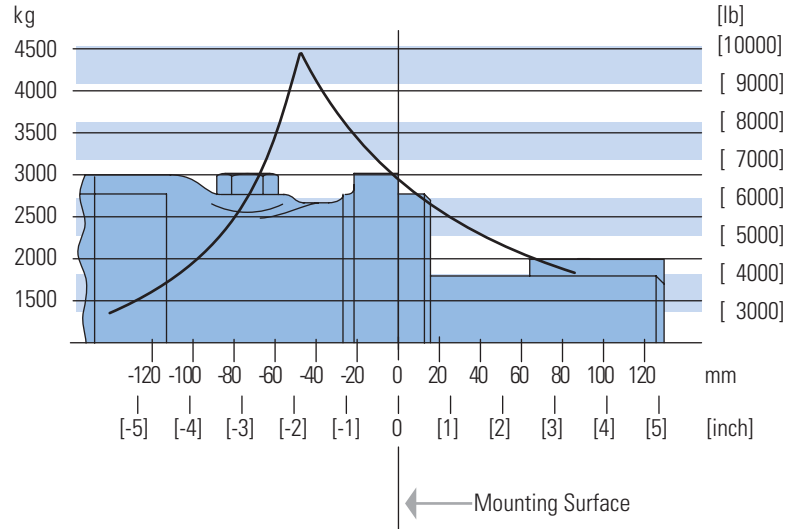

# 10,000 Series

## Dimensions

### Ports

#### 1 1/4 Inch Split Flange Ports (2)

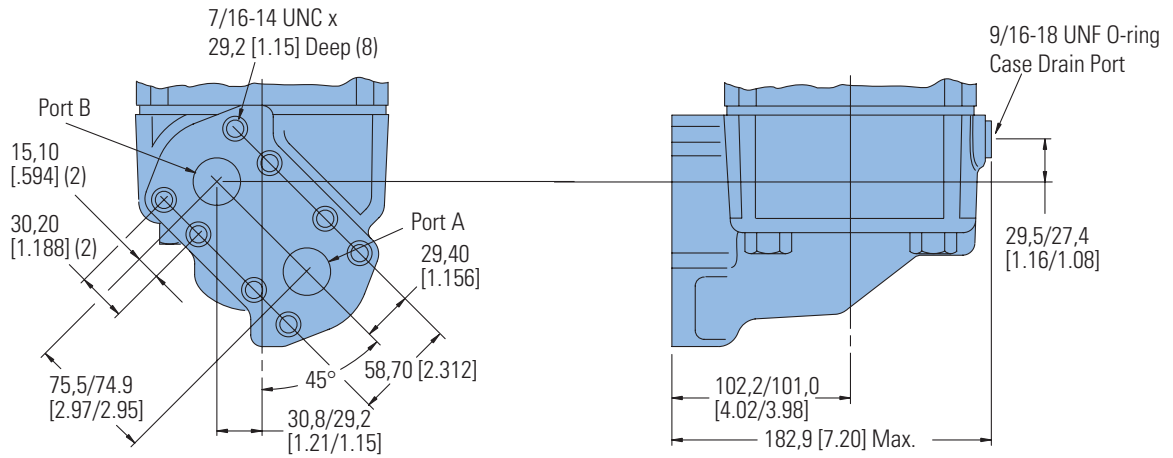

#### 1 5/16 -12 O-ring Ports (2)

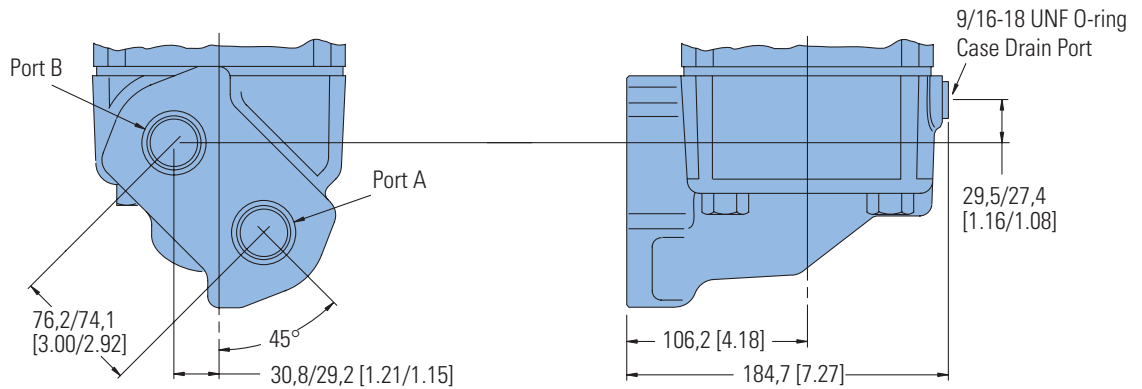

#### End View Common Dimensions

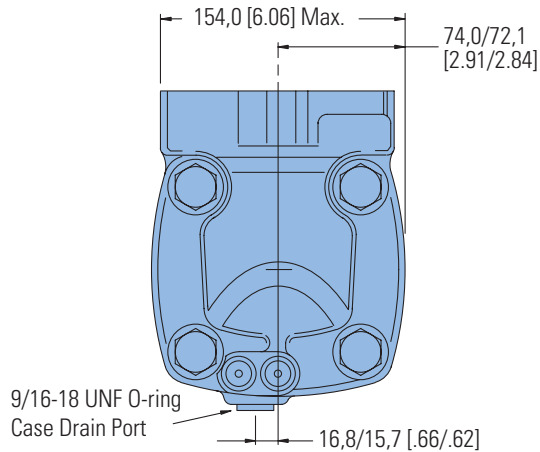

C-6



# 10,000 Series

## Product Numbers

### Note:

For 10,000 Series Motors with a configuration **Not Shown** in the chart below: Use model code number system on the next page to specify product in detail.

Use digit prefix — 119-, 120-, or 121 - plus four digit number from charts for complete product number— Example 121-1014.

**Orders will not be accepted without three digit prefix.**

MOUNTING	SHAFT	PORT SIZE	DISPL. cm <sup>3</sup> /r [in <sup>3</sup> /r] / PRODUCT NUMBER			
			345 [21.0]	480 [29.3]	665 [40.6]	940 [57.4]
Standard SAE C-Mount	2 1/4 Inch Straight	1 5/16 O-ring	119-1028	-1029	-1030	-1031
		1 1/4 inch Split Flange	119-1040	-1041	-1042	-1043
	2 1/8 Inch 16 T Splined	1 5/16 O-ring	119-1032	-1033	-1034	-1035
		1 1/4 inch Split Flange	119-1044	-1045	-1046	-1047
	2 1/4 Inch Tapered	1 5/16 O-ring	119-1036	-1037	-1038	-1039
		1 1/4 inch Split Flange	119-1048	-1049	-1050	-1051
Wheel Motor	2 1/4 Inch Straight	1 5/16 O-ring	120-1005	-1006	-1007	-1008
		1 1/4 inch Split Flange	120-1017	-1018	-1019	-1020
	2 1/8 Inch 16 T Splined	1 5/16 O-ring	120-1009	-1010	-1011	-1012
		1 1/4 inch Split Flange	120-1021	-1022	-1023	-1024
	2 1/4 Inch Tapered	1 5/16 O-ring	120-1013	-1014	-1015	-1016
		1 1/4 inch Split Flange	120-1025	-1026	-1027	-1028
Bearingless		1 5/16 O-ring	121-1007	-1008	-1009	-1010
		1 1/4 inch Split Flange	121-1011	-1012	-1013	-1014

121-1014

# 10,000 Series

## Model Code

The following 30-digit coding system has been developed to identify all of the configuration options for the 10,000 Series motor. Use this model code to specify a motor with the desired features. All 30-digits of the code must be present when ordering. You may want to photocopy the matrix below to ensure that each number is entered in the correct box.

M	1	0	***	**	**	**	**	**	*	00	*	*	**	00	**	**	00	*											
1	2	3	4	5	6	7	8	9	10	11	12	13	14	15	16	17	18	19	20	21	22	23	24	25	26	27	28	29	30

**1** Product  
M – Motor

**2**, **3** Series  
10 – 10,000 Series

**4**, **5**, **6** Displacement  
cm<sup>3</sup>/r [in<sup>3</sup>/r]

210 – 343.8 [20.98]  
293 – 479.5 [29.26]  
406 – 665.3 [40.60]  
574 – 940.8 [57.41]

**7**, **8** Mounting  
Description

AA – Standard, 4 Bolt: 127,0 [5.00] Pilot Dia. 16,76 [.660] Dia. Holes on 161,92 [6.375] Dia. Bolt Circle

AB – Wheel, 4 Bolt: 16,76 [.660] Dia. Holes on 209,55 [8.250] Dia. Bolt Circle

AC – Bearingless, 4 Bolt: 152,4 [6.00] Pilot Dia. 20,70 [.815] Holes on 228,60 [9.00] Dia. Bolt Circle

**9**, **10** Output Shaft  
Description

00 – None (Bearingless)

**01** – 57,15 [2.250] Dia. Straight with .500-20 UNF-2B Thread in End, 12,7 [.50] Square x 63,5 [2.50] Straight End

**02** – 57,15 [2.250] Dia. .125:1 Tapered Shaft Per SAE J512 with 1.500-18 UNEF-2A Threaded Shaft End and Slotted Hex Nut, 14,288 [.5625] Square x 50,8 [2.00] Straight Key

**03** – 53,98 [2.125] Dia. Flat Root, Major Dia. Fit, 16 Tooth, 8/16 DP, 30 Degree Involute Spline with .500-20 UNF-20 Thread in End. 52,07 [2.050] Minimum Full Spline Length

**11**, **12** Ports

AA – 1.3125 -12 UN O-Ring Staggered Ports

AB – 31,75 [1.250] Dia. 4 Bolt Split Flange Staggered Ports with .4375-15 UNC-2B Tapped Mounting Holes

**13**, **14** Case Flow Options  
**01** – .5625-18 UNF-2B Case Drain SAE O-Ring Port

**15** Low Pressure Relief  
**0** – None

**16**, **17** Pressure/Flow  
Option  
**00** – None

**18** Geroler Option  
**0** – Standard  
1 - Free Running

**19** Seal Option

**00** – Standard Seals

**02** – Seal Guard

**03** – Viton Seals

**04** – Viton Shaft Seal

**11** – High pressure shaft seal, slinger seal

**19** – Extreme duty seal guard

**20**, **21** Accessories

**00** – None

**22**, **23** Special Features  
(Hardware)

**00** – None

**24**, **25** Special Features  
(Assembly)

**00** – None

AA – Reverse Rotation

**26**, **27** Paint / Packaging

**00** – None

AA – Low Gloss Black Primer

**28**, **29** Customer  
Identification

**00** – None

**30** Design Code

**C** – Third (Standard and Wheel Mounts)

**D** – Fourth (Bearingless Mount)

Feature in **bold** are preferred and allow for shorter lead time.

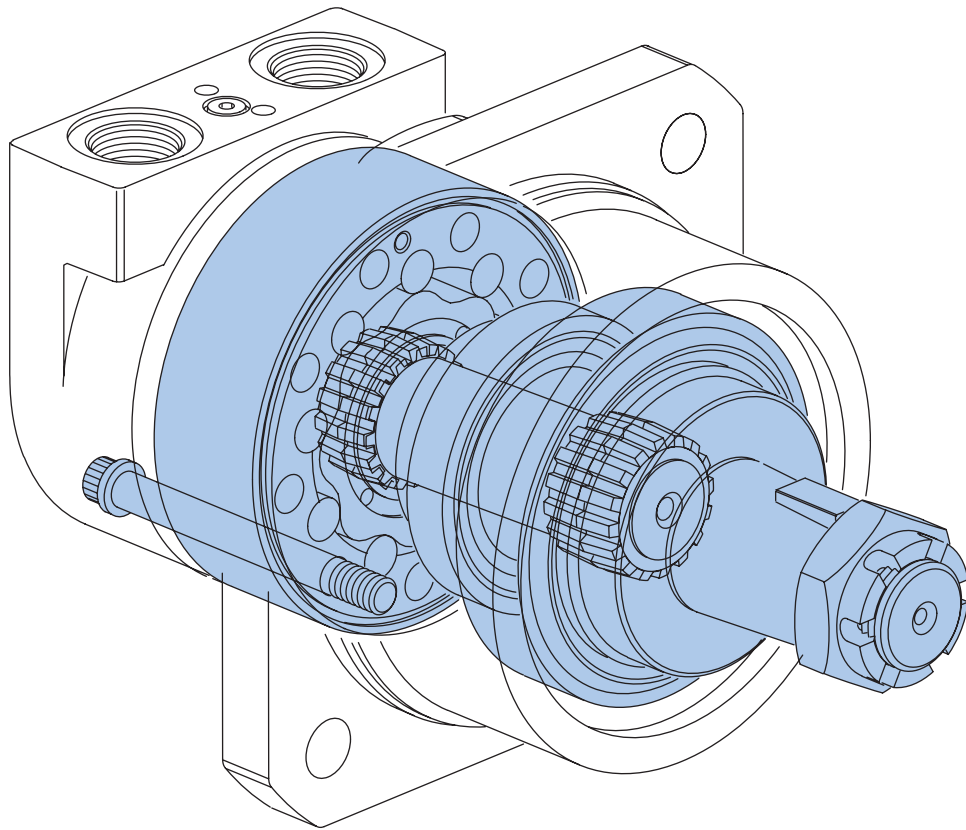

The next step in the evolution of low speed high torque (LSHT) hydraulic motors.

# VIS Motors

## Highlights

### Product Description

The VIS (Valve-in-Star) Motors are the next step in the evolution of the low speed high torque (LSHT) hydraulic motors. The VIS design provides design advantages over other types of LSHT hydraulic motor valving resulting in a more compact package with better efficiency and higher pressure capability. These improvements have shown significant packaging and performance advantages in applications such as skid steer loaders, mini excavators, trenchers and logging equipment.

VIS motors are primarily intended for use in closed loop circuit applications. Consult your Eaton representative for assistance on open loop circuit applications.

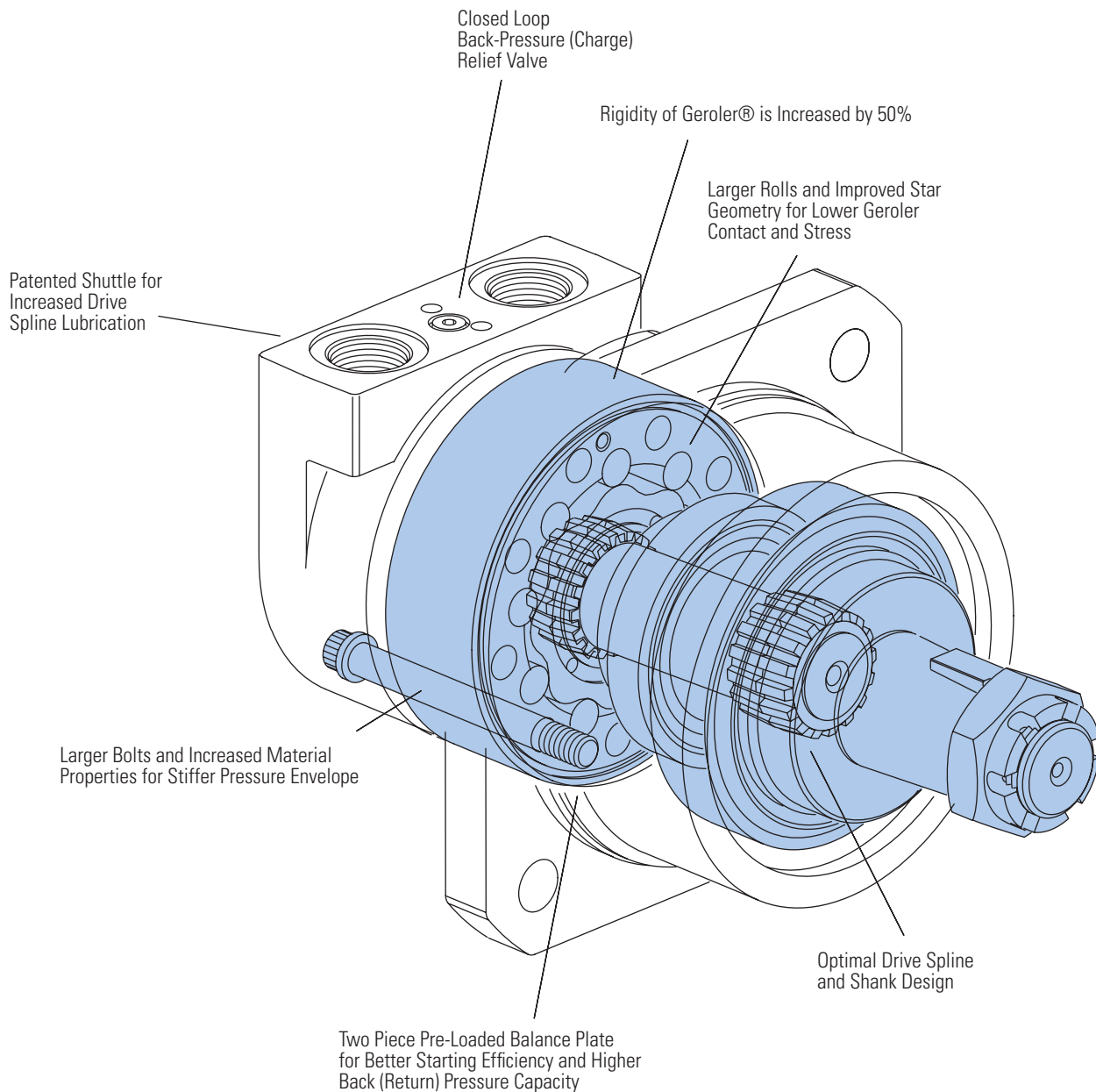

# Features, Benefits, and Applications

## Features

- Patented VIS Geroler technology
- Simplified design - only three moving components:
  - geroler star
  - drive
  - output shaft
- Pressure-balance Geroler - improves efficiency
- Shuttle valve option for reliable internal drive lubrication
- Variety of optional features

## Benefits

- Extremely compact powerful package
- Highest output torque in its class
- High efficiency
- Reduced system temperatures
- High horsepower density
- Design flexibility
- Reliable and dependable performance

## Applications

- Skid steer loaders
- Sprayers
- Underground boring equipment
- Forestry equipment
- Irrigation reels
- Grinders/Mixers
- Material handling equipment
- Augers and skid steer attachments
- Large turf care equipment

## Design Features

Eaton hydraulic motors provide design flexibility. All VIS motors are available with various configurations consisting of:

- Displacement (Geroler)
- Output Shaft
- No Shaft (Bearingless Motor)
- Port Configuration
- Mounting Flange
- Park brake
- Other Special Features

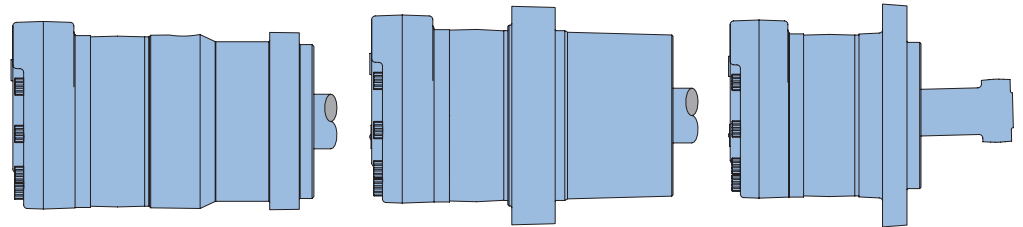

### Standard Motor

The standard motor mounting flange is located as close to the output shaft as possible. This type of mounting supports the motor close to the shaft load. This mounting flange is also compatible with many standard gear boxes.

### Wheel Motor

The wheel motor mounting flange is located near the center of the motor which permits part or all of the motor to be located inside the wheel or roller hub. In traction drive applications, loads can be positioned over the motor bearings for best bearing life. This wheel motor mounting flange provides design flexibility in many applications.

### Bearingless Motor

The bearingless motor has the same drive components as the standard and wheel motors with the exception that the motor is assembled without the output shaft, bearings and bearing housing. The bearingless motor is especially suited for applications such as gear boxes, winch drives, reel and roll drives. Bearingless motor applications must be designed with a bearing supported internal spline to mate with the bearingless motor drive. Product designs using these hydraulic motors provide considerable cost savings.

D-1

D-2

# Table of Contents

Highlights	D-ii	Product Numbers	D-3-13
Features, Benefits, and Applications	D-iii	Model Code	D-3-15
Table of Contents	D-iv	<b>VIS 45 Series Two-speed</b>	
Typical Hydraulic Circuit	D-v	Specifications	D-3-16
<b>VIS 40 Series</b>		Performance Data	D-3-16
Highlights	D-2-1	Dimensions	D-3-17
Specifications	D-2-2	Product Numbers	D-3-20
Performance Data	D-2-3	Model Code	D-3-21
Dimensions	D-2-6		
Installation Information	D-2-10		
Dimensions Shafts	D-2-11		
Side Load Capacity	D-2-12		
Oversize Flange 224,0 [8.82] B.C.	D-2-14		
Product Numbers	D-2-17		
Model Code	D-2-19		
<b>VIS 40 Series Two-speed</b>			
Specifications	D-2-20		
Performance Data	D-2-20		
Dimensions	D-2-21		
Installation Information	D-2-25		
Product Numbers	D-2-26		
Model Code	D-2-27		
Brake Description	D-2-28		
Brake Shaft Dimensions/ Sideload Curves	D-2-30		
<b>VIS 45 Series</b>			
Highlights	D-3-1		
Specifications	D-3-2		
Performance Data	D-3-3		
Dimensions	D-3-6		
Installation Information	D-3-9		
Dimensions Shafts	D-3-10		
Side Load Capacity	D-3-12		

# Typical Hydraulic Circuit

VIS 40 and 45 Series

## Shuttle Valve, Two Way (Closed Center) –

Schematic Diagrams

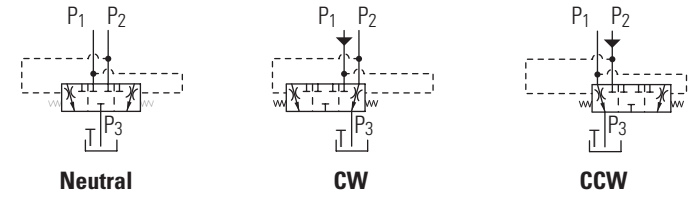

## Closed Loop Circuit

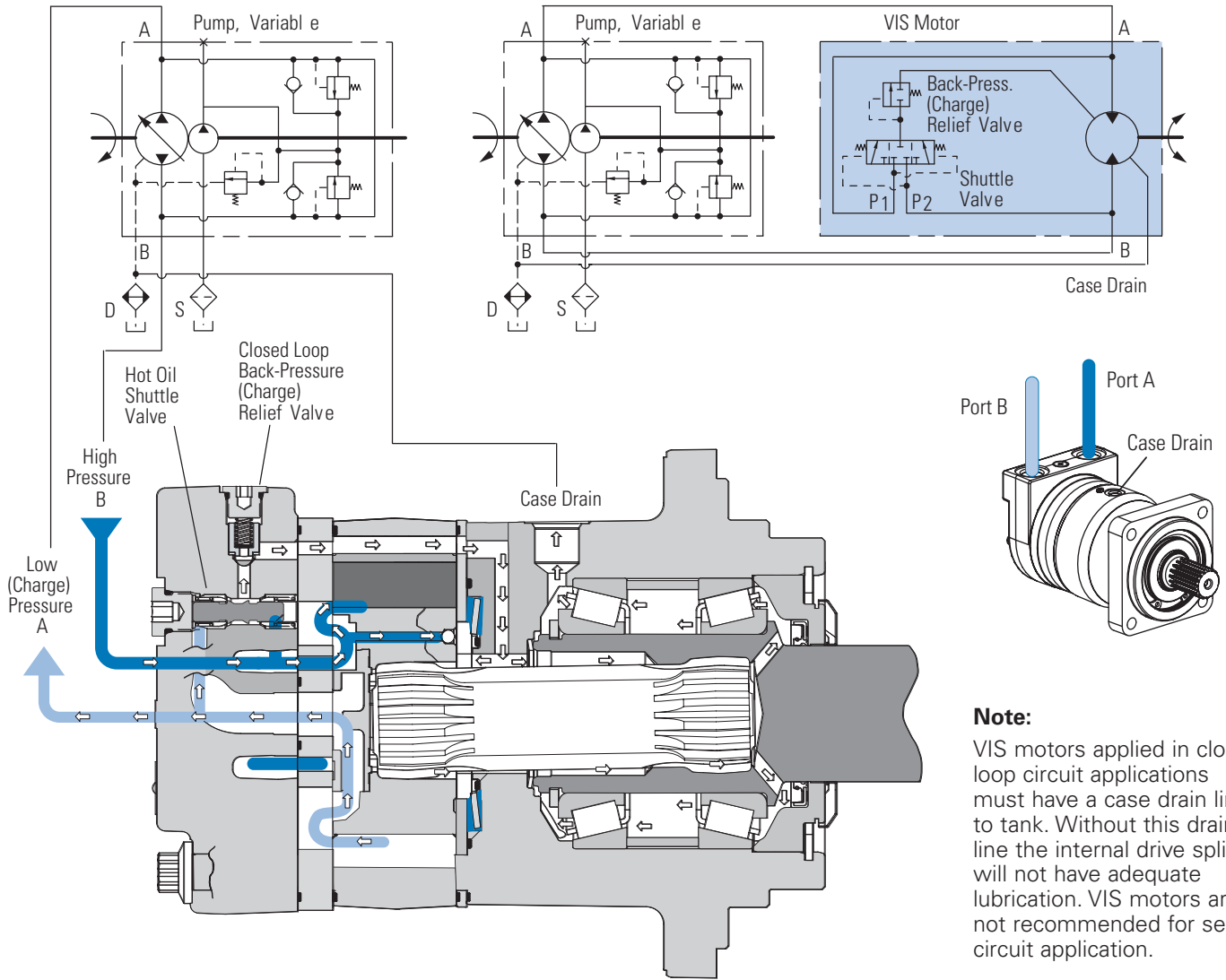

**Note:**  
VIS motors applied in closed loop circuit applications must have a case drain line to tank. Without this drain line the internal drive spline will not have adequate lubrication. VIS motors are not recommended for series circuit application.

## VIS 40 and 45 Motors Shuttle Flow Charts

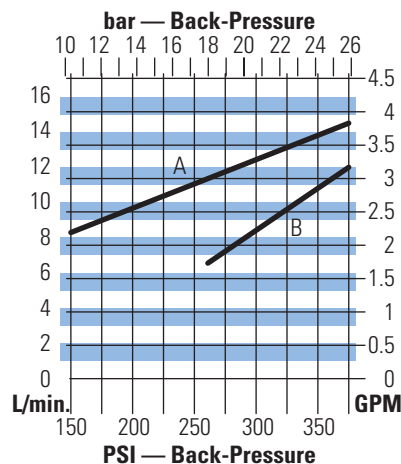

**A**  
4,5 bar [65 PSI] @ 60° C [140° F]

Δ Between Back-Pressure and Case Pressure (Typical Data)

**B**  
15,2 bar [220 PSI] @ 60° C [140° F]

Δ Between Back-Pressure and Case Pressure (Typical Data)

Due to Machining Tolerances, Flow May be More or Less

D-1

D-2

# Typical Hydraulic Circuit

VIS 40 and  
45 Series

## Open Loop Circuit

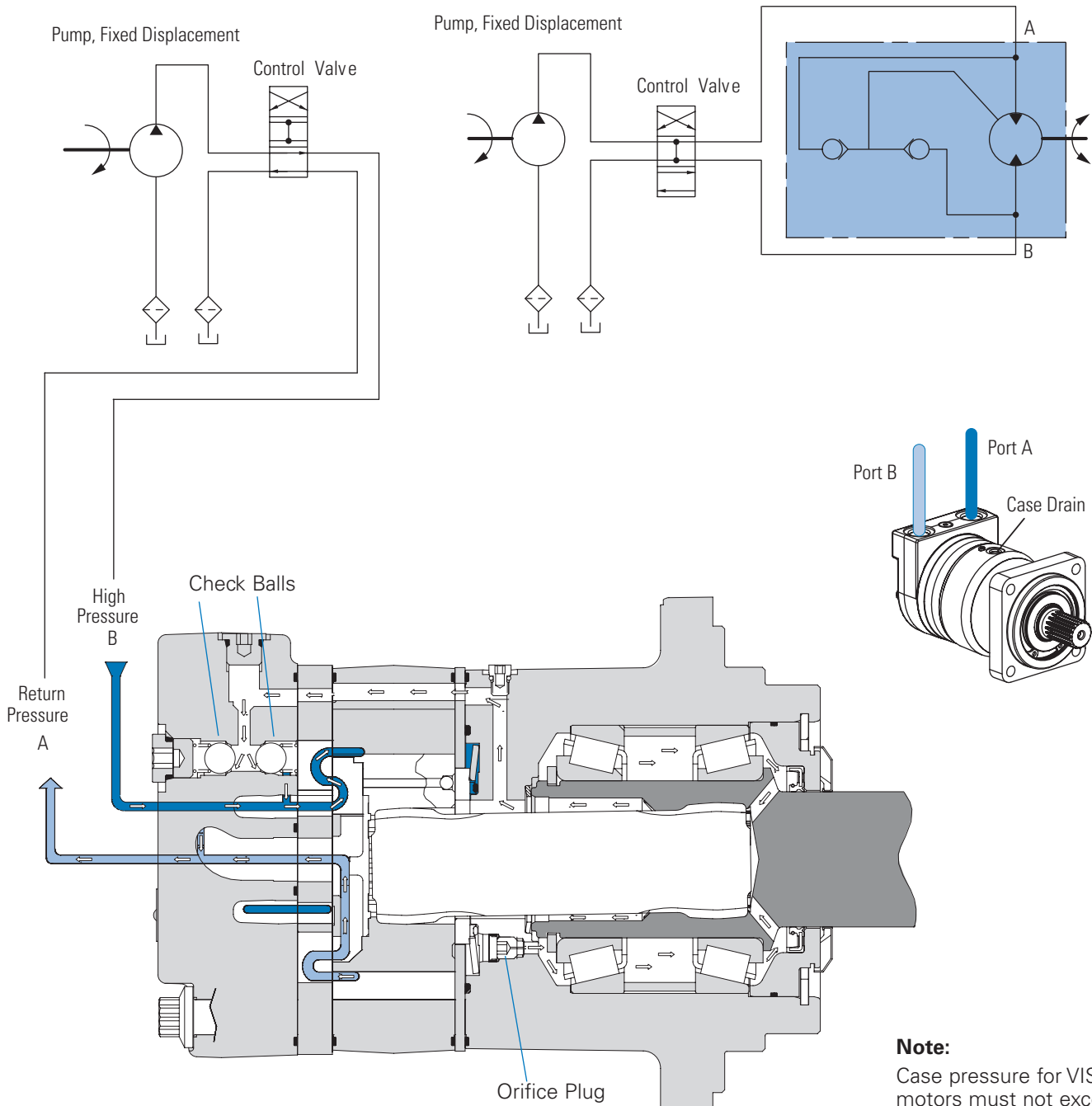

### Note:

Case pressure for VIS motors must not exceed 50 psi. With an "Open Loop Option" VIS motor, a case drain is not required, except if the return pressure is greater than 50 psi.



# Typical Hydraulic Circuit

VIS 40 and  
45 Series

## Two-speed Circuit

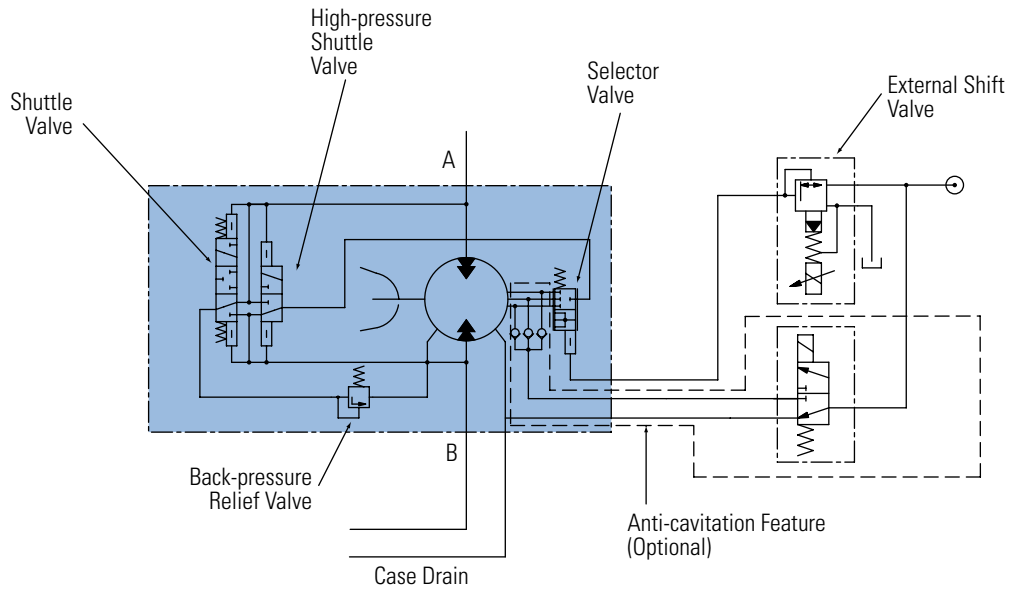

## Two-Speed Brake Motor Circuit

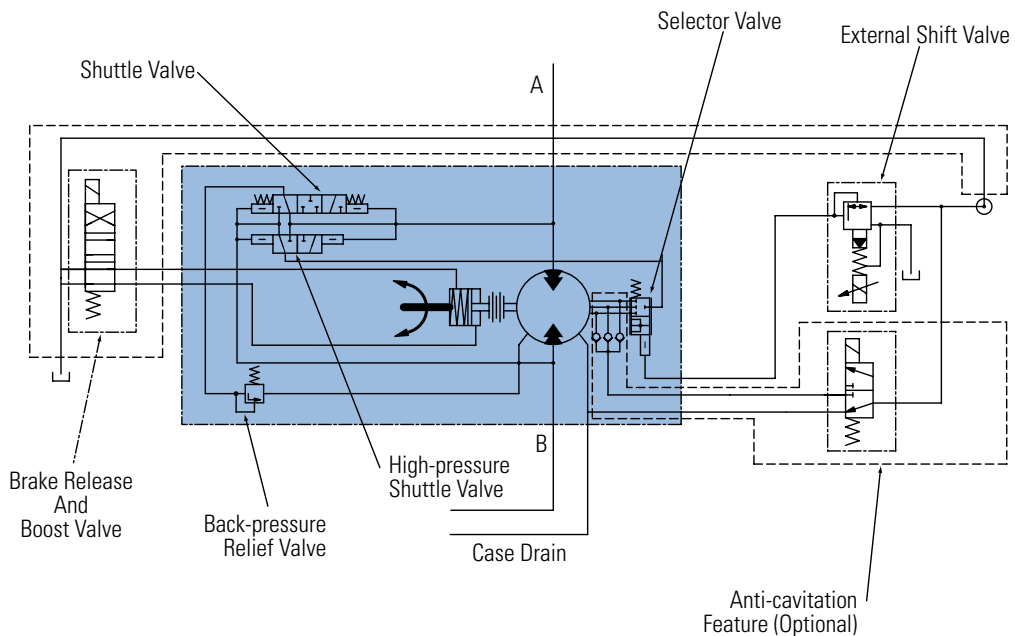

D-1

D-2

# Notes

# VIS 40 Series

## Highlights

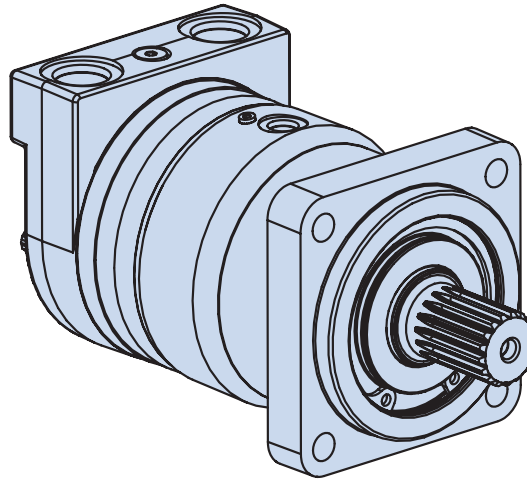

## Features

- Patented VIS Geroler technology
- Three moving components: (Geroler, star, drive, and output shaft)
- Maximized drive strength in compact package size
- Compact package size similar to VIS 30 Series.
- Two-piece pre-loaded pressure balance plate
- Variety of optional features including two-speed option, brake packages, and case flow solutions for both closed-loop and open-loop applications.

## Description

The VIS 40 Series is the newest addition to the VIS product line. The VIS 40 is very close in size to the VIS 30, but with increased drive train strength, it has even greater torque capability. Maximum continuous output torque capability is rated to 2531 Nm [22,400 lb-in] with a displacement range from 505cc to 940cc per revolution. VIS 40 motors can be run up to 151 LPM [40 GPM] with pressure capability up to 310 bar (4500 PSI). The motor utilizes patented VIS technology with improved high-strength Geroler, optimized drive geometry, and two-piece pre-loaded balance plate for increased starting efficiency, reduced leakage and higher back pressure capacity. A wide variety of options are available including two-speed option, brake options and case flow options for both closed-loop and open loop applications.

## Specifications

Geroler Element	8 Displacements
Flow l/min [GPM]	151 [40] Continuous 170 [45] Intermittent
Speed	Up to 454 RPM
Pressure bar [PSI]	310 [4500] Cont. 345 [5000] Inter. 380 [5500] Peak.
Torque Nm [lb - in]	2531 [22400] Cont. 3165 [28000] Inter.

## Benefits

- Extremely compact powerful package
- Increased torque capability
- Greatest horsepower density in the VIS motor line
- High efficiency
- Quiet, smooth operation
- Reliable, trouble-free performance
- Design Flexibility

## Applications

- Skid Steer Loaders and Attachments
- Snow Removal Equipment
- Trenchers
- Grapples
- Rough Terrain Forklifts
- Wood Processing – Saw Mills & Chippers
- Metal Forming
- Entertainment / Amusement Rides
- Industrial Processing
- Harvesters



Skid Steer



Trencher



Digger



Port Equipment

# VIS 40 Series

## Specifications

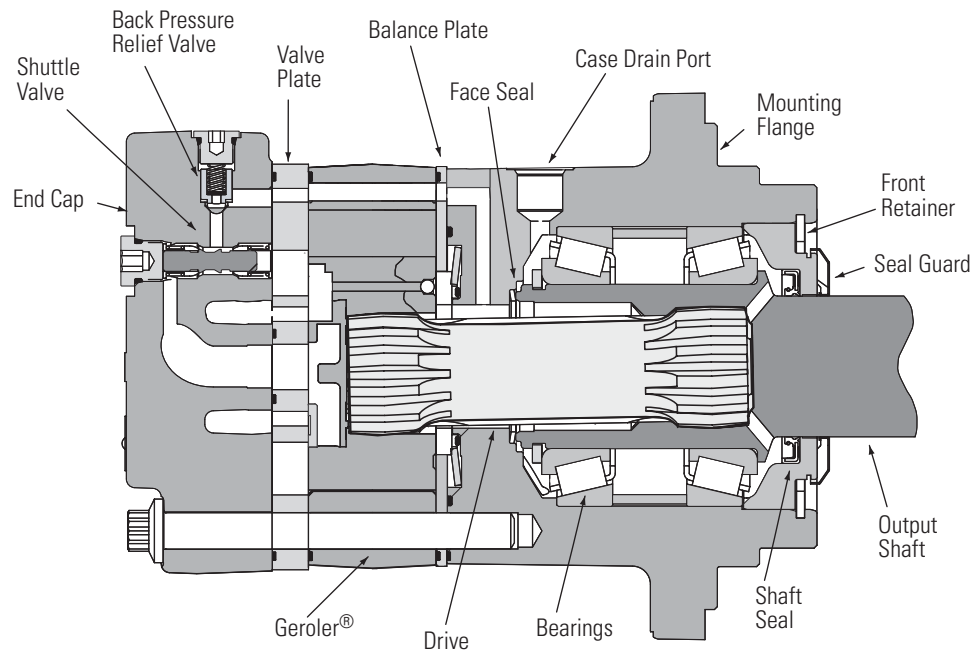

### SPECIFICATION DATA – VIS 40 MOTORS

Displ. cm <sup>3</sup> /r [in <sup>3</sup> /r]		325 [19.8]	400 [24.4]	505 [30.7]	570 [34.9]	630 [38.5]	685 [41.7]	785 [48.0]	940 [57.4]
Max. Speed (RPM) @ Flow	Continuous	440	357	279	244	221	204	177	148
	Intermittent	454	368	293	257	233	215	187	148
Flow l/min [GPM]	Continuous	151 [40]	151 [40]	151 [40]	151 [40]	151 [40]	151 [40]	151 [40]	151 [40]
	Intermittent	170 [45]	170 [45]	170 [45]	170 [45]	170 [45]	170 [45]	170 [45]	170 [45]
Torque Nm [lb - in]	Continuous	1445 [12789]	1781 [15760]	2240 [19829]	2531 [22400]	2531 [22400]	2531 [22400]	2531 [22400]	2531 [22400]
	Intermittent	1986 [17421]	1597 [14137]	2746 [21919]	2815 [24918]	3165 [28000]	3165 [28000]	3165 [28000]	3165 [28000]
Pressure $\Delta$ bar [ $\Delta$ PSI]	Continuous	310 [4500]	310 [4500]	310 [4500]	279 [4040]	254 [3686]	235 [3389]	208 [3012]	171 [2489]
	Intermittent	345 [5000]	345 [5000]	345 [5000]	309 [4486]	315 [4574]	290 [4212]	254 [3682]	214 [3100]
	Peak	380 [5500]	380 [5500]	380 [5500]	380 [5500]	380 [5500]	380 [5500]	300 [4355]	250 [3621]
Weight kg [lb]	Standard or Wheel Mount	28,5 [62.9]	29,1 [64.2]	29,9 [66.0]	30,5 [67.2]	31,4 [68.2]	31,4 [69.2]	32,2 [71.0]	33,4 [73.6]
	Bearingless	16,3 [36.0]	16,9 [37.3]	17,7 [39.1]	18,3 [40.3]	18,7 [41.3]	19,2 [42.3]	20,0 [44.1]	21,2 [46.7]
Weight kg [lb]	Two-speed Standard or Wheel Mount	32,1 [70.8]	32,7 [72.1]	33,5 [73.9]	34,1 [75.1]	34,5 [76.1]	35,0 [77.1]	35,8 [78.9]	37,0 [81.5]
	Two-speed Bearingless	19,9 [43.9]	20,5 [45.2]	21,3 [47.0]	21,9 [48.2]	22,3 [49.2]	22,8 [50.2]	23,6 [52]	24,8 [54.6]

A simultaneous maximum torque and maximum speed NOT recommended.

#### Note:

To assure best motor life, run motor for approximately one hour at 30% of rated pressure before application to full load. Be sure motor is filled with fluid prior to any load applications.

#### Maximum Inlet Pressure:

400 bar [5800 PSI]  
Do Not Exceed A Pressure Rating (for displacement size see chart above).

#### Return Pressure (Back-Pressure):

Minimum – 3,5 bar [50 PSI]  
Maximum – 21 bar [300 PSI]

#### Note:

Return (back-pressure) must be 3,5 bar [50 PSI] greater than the case pressure, except with open loop circuit.

#### $\Delta$ Pressure:

The true  $\Delta$  bar [ $\Delta$ PSI] between inlet port and outlet port

#### Case Pressure:

Minimum – No Pressure  
Maximum – 3,5 bar [50 PSI]

#### Note:

The case must be full when the motor is operating. A case drain is recommended.

#### Continuous Rating:

Motor may be run continuously at these ratings

#### Intermittent Operation:

10% of every minute

#### Peak Operation:

1% of every minute

#### Recommended Fluids:

Premium quality, anti-wear type hydraulic oil with a viscosity of not less than 70 SUS at operating temperature.

#### Recommended System Operating Temp.:

-34°C to 82°C [-30°F to 180°F]

#### Recommended Filtration:

Per ISO Cleanliness Code, 4406: 20/18/13

#### Shuttle:

Standard

#### Back-Pressure Relief Valve:



Required for closed loop circuit.

# VIS 40 Series

## Performance Data

Motors run with high efficiency in all areas designated with a number for torque and speed. For best motor life select a motor to run with a torque and speed range shown in the light shaded area.

Performance data is typical at 120 SUS. Actual data may vary slightly from unit to unit in production.

-  Continuous
-  Intermittent
-  Will Operate at Reduced Life

### 325 cm<sup>3</sup>/r [19.8 in<sup>3</sup>/r]

Δ Pressure Bar [PSI]

	250	500	1000	1500	2000	2500	3000	3500	4000	4500	5000	5500
	15	35	70	105	140	170	205	240	275	310	345	380
4	668	1399	2834	4251	5583	6924	8258	9528	10387	11637	12659	
	75	158	320	480	631	782	933	1076	1174	1315	1430	
15	46	46	46	44	43	43	42	42	39	37	36	
	680	1419	2867	4303	5711	7126	8530	9876	11269	12460	13782	14840
8	77	160	324	486	645	805	964	1116	1273	1408	1557	1677
	93	91	90	87	85	84	83	81	78	74	70	66
12	647	1412	2879	4340	5768	7195	8619	10010	11360	12672	14029	15246
	73	160	325	490	652	813	974	1131	1284	1432	1585	1723
45	139	137	133	132	129	129	129	127	126	124	113	109
	690	1420	2852	4316	5741	7191	8621	10014	11412	12736	14081	15435
16	78	160	322	488	649	812	974	1131	1289	1439	1591	1744
	61	186	184	181	179	174	170	168	166	161	154	151
20	657	1250	2774	4407	5695	7170	8741	9952	11392	12789	14137	15339
	74	141	313	498	643	810	988	1124	1287	1445	1597	1733
76	233	229	226	223	217	214	211	209	208	203	200	197
	544	1266	2814	4154	5858	7220	8518	9936	11269	12654	14037	15334
25	61	143	318	469	662	816	962	1123	1273	1430	1586	1732
	95	291	283	280	277	269	266	264	260	256	254	248
30	146	1177	2605	3968	5401	6882	8315	9678	11092	12536	13960	15321
	16	133	294	448	610	778	939	1094	1253	1416	1577	1731
114	341	345	340	336	333	325	323	320	316	312	307	303
	114	1144	2532	3960	5322	6768	8232	9589	11019	12228	13298	15023
35	13	129	286	447	601	765	930	1083	1245	1382	1503	1697
	132	396	402	396	392	387	378	372	369	363	353	354
40	92	557	2047	3574	5032	6507	7944	9282	10687	12112	13439	14938
	10	63	231	404	569	735	898	1049	1207	1368	1518	1688
151	454	452	440	433	430	429	430	428	425	420	413	408

### 400 cm<sup>3</sup>/r [24.4 in<sup>3</sup>/r]

Δ Pressure Bar [PSI]

	250	500	1000	1500	2000	2500	3000	3500	4000	4500	5000	5500
	15	35	70	105	140	170	205	240	275	310	345	380
4	823	1724	3493	5239	6880	8532	10177	11741	12800	14340	15600	
	93	195	395	592	777	964	1150	1327	1446	1620	1763	
15	37	37	37	36	35	35	34	34	32	30	29	
	838	1749	3533	5302	7038	8781	10511	12171	13887	15354	16983	18288
8	95	198	399	599	795	992	1188	1375	1569	1735	1919	2066
	75	74	73	71	69	68	67	66	63	60	57	53
12	797	1740	3548	5349	7108	8866	10622	12335	13999	15616	17289	18788
	90	197	401	604	803	1002	1200	1394	1582	1764	1953	2123
45	113	111	108	107	105	105	105	103	102	101	92	88
	850	1750	3515	5319	7074	8862	10624	12341	14063	15695	17353	19021
16	96	198	397	601	799	1001	1200	1394	1589	1773	1961	2149
	61	151	149	147	145	141	138	136	136	131	125	123
20	810	1540	3419	5431	7018	8836	10771	12264	14039	15760	17421	18902
	92	174	386	614	793	998	1217	1386	1586	1781	1968	2136
76	189	186	183	181	176	174	171	170	169	165	163	160
	670	1560	3467	5118	7219	8897	10497	12244	13887	15594	17299	18896
25	76	176	392	578	816	1005	1186	1383	1569	1762	1954	2135
	95	236	233	230	227	225	218	216	211	208	206	202
30	180	1450	3210	4890	6656	8480	10246	11927	13669	15448	17203	18881
	20	164	363	552	752	958	1158	1348	1544	1745	1944	2133
114	277	280	276	273	270	264	262	259	256	253	250	246
	140	1410	3120	4880	6559	8341	10144	11817	13579	15068	16388	18514
35	16	159	353	551	741	942	1146	1335	1534	1702	1852	2092
	132	321	326	321	318	314	307	306	299	295	287	287
40	113	687	2522	4405	6201	8019	9789	11438	13170	14926	16561	18409
	13	78	285	498	701	906	1106	1292	1488	1686	1871	2080
151	368	367	357	352	349	348	349	347	345	341	335	331

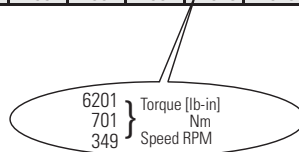



# VIS 40 Series

**505 cm<sup>3</sup>/r [30.7 in<sup>3</sup>/r]**  
 $\Delta$  Pressure Bar [PSI]

## Performance Data

Motors run with high efficiency in all areas designated with a number for torque and speed. For best motor life select a motor to run with a torque and speed range shown in the light shaded area.

Performance data is typical at 120 SUS. Actual data may vary slightly from unit to unit in production.

-  Continuous
-  Intermittent
-  Will Operate at Reduced Life

Flow LPM [GPM]	$\Delta$ Pressure Bar [PSI]											
	250 15	500 35	1000 70	1500 105	2000 140	2500 170	3000 205	3500 240	4000 275	4500 310	5000 345	5500 380
4	1035	2169	4395	6592	8656	10735	12804	14773	16105	18043	19628	
15	117	245	497	745	978	1213	1447	1669	1820	2039	2218	
8	1055	2200	4445	6671	8855	11049	13225	15313	17473	19319	21368	23010
30	119	249	502	754	1000	1248	1494	1730	1974	2183	2414	2600
12	1003	2190	4464	6730	8944	11155	13364	15520	17614	19648	21753	23640
45	113	247	504	760	1011	1260	1510	1754	1990	2220	2458	2671
16	1069	2202	4422	6692	8901	11150	13367	15527	17694	19747	21833	23932
61	121	249	500	756	1006	1260	1510	1754	1999	2231	2467	2704
20	1019	1938	4301	6833	8830	11117	13552	15431	17663	19829	21919	23783
76	115	219	486	772	998	1256	1531	1743	1996	2240	2476	2687
25	843	1963	4363	6440	9083	11194	13207	15406	17473	19620	21765	23775
95	95	222	493	728	1026	1265	1492	1741	1974	2217	2459	2686
30	226	1824	4039	6153	8375	10670	12892	15006	17199	19437	21645	23756
114	26	206	456	695	946	1206	1457	1695	1943	2196	2446	2684
35	176	1774	3926	6140	8252	10494	12763	14868	17086	18959	20619	23294
132	20	200	444	694	932	1186	1442	1680	1930	2142	2330	2632
40	142	864	3174	5542	7803	10089	12317	14391	16570	18779	20837	23162
151	16	98	359	626	882	1140	1392	1626	1872	2122	2354	2617
	293	292	284	279	277	277	277	276	274	271	267	263

**570cm<sup>3</sup>/r [34.9 in<sup>3</sup>/r]**  
 $\Delta$  Pressure Bar [PSI]

Flow LPM [GPM]	$\Delta$ Pressure Bar [PSI]											
	250 15	500 35	1000 70	1500 105	2000 140	2500 170	3000 205	3500 240	4000 275	4500 310	5000 345	5500 380
4	1177	2466	4996	7494	9841	12204	14556	16794	18308	20511	22313	
15	133	279	564	847	1112	1379	1645	1897	2069	2317	2521	
8	1199	2501	5053	7584	10067	12560	15034	17408	19864	21962	24292	26158
30	135	283	571	857	1137	1419	1699	1967	2244	2481	2745	2955
12	1140	2489	5074	7650	10167	12681	15193	17644	20024	22336	24729	26874
45	129	281	573	864	1149	1433	1717	1993	2262	2524	2794	3036
16	1216	2503	5027	7608	10119	12675	15195	17652	20115	22449	24820	27206
61	137	283	568	860	1143	1432	1717	1994	2273	2536	2804	3074
20	1159	2203	4890	7768	10038	12638	15407	17542	20080	22542	24918	27037
76	131	249	552	878	1134	1428	1741	1982	2269	2547	2815	3055
25	958	2231	4960	7321	10325	12725	15014	17513	19863	22305	24743	27027
95	108	252	560	827	1167	1438	1696	1979	2244	2520	2796	3054
30	257	2074	4591	6994	9520	12130	14656	17059	19552	22096	24606	27006
114	29	234	519	790	1076	1370	1656	1927	2209	2496	2780	3051
35	200	2017	4463	6980	9381	11930	14509	16902	19423	21553	23440	26481
132	23	228	504	789	1060	1348	1639	1910	2195	2435	2648	2992
40	162	983	3608	6300	8870	11469	14002	16360	18837	21348	23688	2633
151	18	111	408	712	1002	1296	1582	1848	2128	2412	2676	2975
	257	257	249	246	244	243	244	243	241	238	234	232

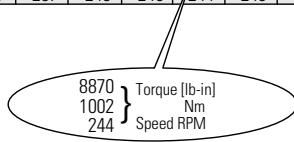

# VIS 40 Series



**630 cm<sup>3</sup>/r [38.5 in<sup>3</sup>/r]**

Δ Pressure Bar [PSI]

## Performance Data

Motors run with high efficiency in all areas designated with a number for torque and speed. For best motor life select a motor to run with a torque and speed range shown in the light shaded area.

Performance data is typical at 120 SUS. Actual data may vary slightly from unit to unit in production.

-  Continuous
-  Intermittent
-  Will Operate at Reduced Life

Flow LPM [GPM]	630 cm <sup>3</sup> /r [38.5 in <sup>3</sup> /r]											
	250 15	500 35	1000 70	1500 105	2000 140	2500 170	3000 205	3500 240	4000 275	4500 310	5000 345	5500 380
4	1298	2720	5511	8267	10856	13463	16058	18526	20197	22627	24615	
15	147	307	623	934	1227	1521	1814	2093	2282	2556	2781	
8	1323	2759	5575	8366	11105	13856	16585	19204	21913	24227	26797	28856
15	149	312	630	945	1255	1565	1874	2170	2476	2737	3028	3260
30	48	47	46	45	44	43	42	42	40	38	36	34
12	1257	2746	5598	8439	11216	13990	16760	19464	22089	24640	27279	29646
15	142	310	632	954	1267	1581	1894	2199	2496	2784	3082	3350
45	72	70	68	68	67	67	67	65	65	64	58	56
16	1341	2761	5546	8393	11163	13982	16763	19472	22190	24765	27381	30012
15	152	312	627	948	1261	1580	1894	2200	2507	2798	3094	3391
61	96	94	93	92	89	87	86	86	86	83	79	78
20	1278	2430	5394	8569	11073	13942	16996	19352	22151	24867	27488	29825
15	144	275	609	968	1251	1575	1920	2186	2503	2810	3106	3370
76	120	118	116	115	112	110	108	108	107	104	103	102
25	1057	2461	5471	8076	11390	14038	16563	19320	21912	24605	27295	29815
15	119	278	618	912	1287	1586	1871	2183	2476	2780	3084	3369
95	150	148	146	144	143	138	137	136	134	132	130	128
30	283	2288	5065	7716	10502	13381	16167	18819	21569	24375	27145	29792
15	32	258	572	872	1187	1512	1827	2126	2437	2754	3067	3366
114	175	177	175	173	171	167	166	164	163	160	158	156
35	221	2225	4923	7700	10349	13160	16006	18646	21427	23776	25858	29212
15	25	251	556	870	1169	1487	1808	2107	2421	2686	2922	3301
132	204	207	203	202	199	194	194	191	190	187	182	182
40	178	1084	3980	6950	9785	12652	15446	18048	20780	23551	26132	29047
15	20	122	450	785	1106	1430	1745	2039	2348	2661	2952	3282
151	233	233	226	223	221	221	220	220	219	216	213	210

**685 cm<sup>3</sup>/r [41.7 in<sup>3</sup>/r]**

Δ Pressure Bar [PSI]

Flow LPM [GPM]	685 cm <sup>3</sup> /r [41.7 in <sup>3</sup> /r]											
	250 15	500 35	1000 70	1500 105	2000 140	2500 170	3000 205	3500 240	4000 275	4500 310	5000 345	5500 380
4	1406	2947	5969	8954	11758	14582	17392	20066	21875	24507	26661	
15	159	333	674	1012	1328	1647	1965	2267	2472	2769	3012	
8	1433	2989	6038	9062	12028	15007	17964	20800	23734	26241	29025	31254
15	162	338	682	1024	1359	1696	2030	2350	2682	2965	3279	3531
30	44	43	43	42	40	40	39	39	37	35	33	31
12	1362	2974	6063	9141	12148	15152	18153	21082	23925	26688	29547	32110
15	154	336	685	1033	1373	1712	2051	2382	2703	3015	3338	3628
45	66	65	63	63	61	61	61	60	60	59	54	52
16	1453	2991	6007	9090	12090	15145	18156	21091	24034	26823	29656	32506
15	164	338	679	1027	1366	1711	2051	2383	2715	3031	3351	3673
61	88	87	86	85	83	81	80	80	79	77	73	72
20	1384	2632	5842	9281	11994	15100	18408	20960	23992	26934	29773	32304
15	156	297	660	1049	1355	1706	2080	2368	2711	3043	3364	3650
76	111	109	107	106	103	102	100	99	99	96	95	94
25	1145	2666	5926	8748	12337	15205	17939	20926	23733	26650	29563	32293
15	129	301	670	988	1394	1718	2027	2364	2681	3011	3340	3649
95	138	136	135	133	132	128	126	126	124	122	120	118
30	307	2478	5486	8357	11375	14493	17511	20383	23361	26401	29401	32268
15	35	280	620	944	1285	1637	1978	2303	2639	2983	3322	3646
114	162	164	161	160	158	154	153	152	150	148	146	144
35	239	2410	5332	8340	11209	14254	17337	20196	23207	25752	28007	31640
15	27	272	602	942	1266	1610	1959	2282	2622	2910	3164	3575
132	188	191	188	186	184	179	179	177	175	172	168	168
40	193	1174	4311	7527	10598	13704	16730	19548	22507	25508	28304	31461
15	22	133	487	850	1197	1548	1890	2209	2543	2882	3198	3555
151	215	215	209	206	204	204	204	203	202	199	196	194

10598 } Torque [lb-in]  
1197 } Nm  
204 } Speed RPM



# VIS 40 Series

**785 cm<sup>3</sup>/r [48.0 in<sup>3</sup>/r]**  
 $\Delta$  Pressure Bar [PSI]

## Performance Data

Motors run with high efficiency in all areas designated with a number for torque and speed. For best motor life select a motor to run with a torque and speed range shown in the light shaded area.

Performance data is typical at 120 SUS. Actual data may vary slightly from unit to unit in production.

-  Continuous
-  Intermittent
-  Will Operate at Reduced Life

Flow LPM [GPM]	785 cm <sup>3</sup> /r [48.0 in <sup>3</sup> /r]											
	250 15	500 35	1000 70	1500 105	2000 140	2500 170	3000 205	3500 240	4000 275	4500 310	5000 345	
4	1618	3392	6871	10306	13535	16784	20020	23097	25180	28210	30689	
	183	383	776	1164	1529	1896	2262	2610	2845	3187	3467	
	15	19	19	19	18	18	18	17	17	16	15	15
8	1649	3440	6950	10431	13845	17275	20678	23942	27320	30205	33410	
	186	389	785	1178	1564	1952	2336	2705	3087	3413	3775	
	30	38	38	37	36	35	35	34	34	32	31	29
12	1568	3423	6979	10522	13984	17441	20895	24267	27540	30720	34011	
	177	387	789	1189	1580	1971	2361	2742	3112	3471	3843	
	45	57	56	55	54	53	53	53	52	52	51	47
16	1672	3443	6914	10464	13917	17433	20899	24277	27665	30876	34137	
	189	389	781	1182	1572	1970	2361	2743	3126	3488	3857	
	61	77	76	75	74	72	70	69	69	69	67	64
20	1593	3030	6725	10683	13805	17382	21190	24127	27617	31003	34271	
	180	342	760	1207	1560	1964	2394	2726	3120	3503	3872	
	76	96	95	93	92	89	88	87	86	84	83	
25	1318	3069	6821	10069	14201	17502	20649	24087	27319	30677	34030	
	149	347	771	1138	1604	1977	2333	2721	3087	3466	3845	
	95	120	118	117	115	114	111	110	109	107	106	105
30	353	2852	6315	9620	13094	16683	20157	23463	26891	30390	33843	
	40	322	713	1087	1479	1885	2277	2651	3038	3434	3824	
	114	141	142	140	139	137	134	133	132	130	129	127
35	275	2774	6138	9600	12903	16408	19956	23247	26714	29643	32238	
	31	313	693	1085	1458	1854	2255	2627	3018	3349	3642	
	132	163	166	163	162	160	156	155	154	152	150	146
40	222	1351	4962	8665	12200	15774	19257	22501	25908	29362	32580	
	25	153	561	979	1378	1782	2176	2542	2927	3317	3681	
	151	187	187	181	179	177	177	177	175	173	170	

**940 cm<sup>3</sup>/r [57.4 in<sup>3</sup>/r]**  
 $\Delta$  Pressure Bar [PSI]

Flow LPM [GPM]	940 cm <sup>3</sup> /r [57.4 in <sup>3</sup> /r]									
	250 15	500 35	1000 70	1500 105	2000 140	2500 170	3000 205	3500 240	4000 275	
4	1935	4056	8216	12325	16185	20071	23940	27620	30111	
	219	458	928	1393	1829	2268	2705	3121	3402	
	15	16	16	16	15	15	14	14	14	14
8	1972	4114	8311	12473	16557	20658	24727	28631	32670	
	223	465	939	1409	1871	2334	2794	3235	3691	
	30	32	31	31	30	29	29	28	28	27
12	1875	4094	8346	12582	16722	20857	24987	29019	32933	
	212	463	943	1422	1889	2357	2823	3279	3721	
	45	48	47	46	45	45	45	44	44	43
16	2000	4117	8268	12513	16642	20846	24992	29032	33083	
	226	465	934	1414	1880	2355	2824	3280	3738	
	61	64	63	62	62	60	59	58	58	57
20	1905	3623	8042	12776	16509	20786	25339	28851	33025	
	215	409	909	1443	1865	2348	2863	3260	3731	
	76	80	79	78	77	75	74	73	72	72
25	1576	3670	8157	12041	16982	20929	24693	28804	32669	
	178	415	922	1360	1919	2365	2790	3254	3691	
	95	100	99	98	96	96	93	92	91	90
30	423	3411	7551	11504	15658	19950	24104	28057	32157	
	48	385	853	1300	1769	2254	2723	3170	3633	
	114	118	119	117	116	115	112	111	110	109
35	329	3317	7340	11480	15429	19621	23864	27799	31945	
	37	375	829	1297	1743	2217	2696	3141	3609	
	132	137	139	136	135	133	130	130	128	127
40	266	1616	5934	10361	14589	18863	23029	26907	30982	
	30	183	670	1171	1648	2131	2602	3040	3500	
	151	156	156	152	149	148	148	148	148	147

5934 } Torque [lb-in]  
 670 } Nm  
 152 } Speed RPM



# VIS 40 Series

## Dimensions

Standard and Wheel Mount  
– SAE

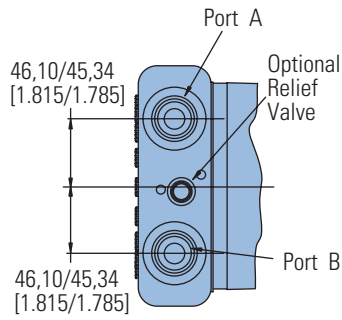

## Ports

- 1–1/16-12 UN-2B SAE O-ring Ports (2)
- 9/16-18 UNF-2B SAE O-ring Case Drain Port (1)

## Standard Rotation Viewed from Shaft End

- Port A Pressurized — CW
- Port B Pressurized — CCW

## Standard Motors (SAE)

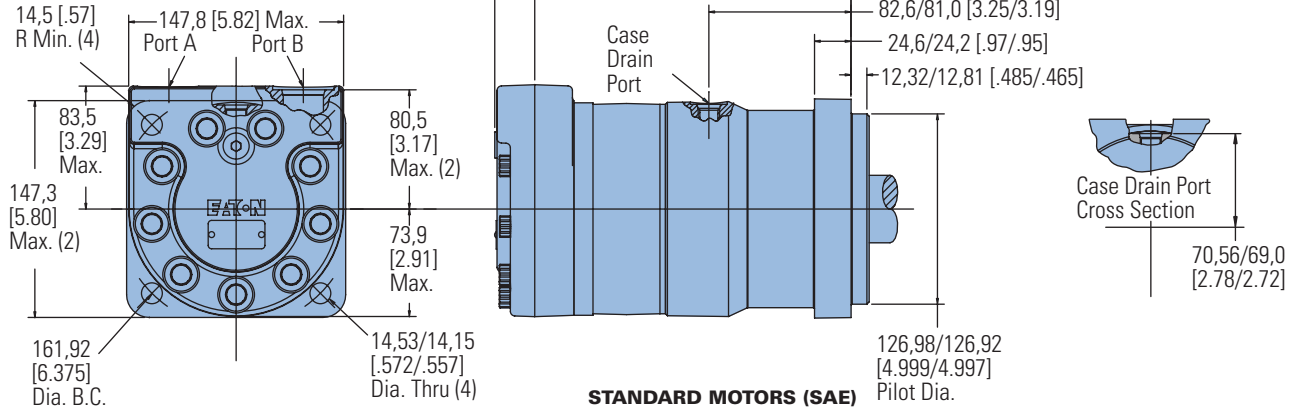

### STANDARD MOTORS (SAE)

Displacement cm <sup>3</sup> /r [in <sup>3</sup> /r]	X mm [inch]	Y mm [inch]
325 [19.8]	223,5 [8.80]	195,3 [7.69]
400 [24.4]	230,4 [9.07]	201,9 [7.95]
505 [30.7]	239,3 [9.42]	211,1 [8.31]
570 [34.9]	245,4 [9.66]	217,2 [8.55]
630 [38.5]	250,7 [9.87]	222,5 [8.76]
685 [41.7]	255,3 [10.05]	227,1 [8.94]
785 [48.0]	264,7 [10.42]	236,2 [9.30]
940 [57.4]	278,4 [10.96]	249,9 [9.84]

## Wheel Motors (SAE)

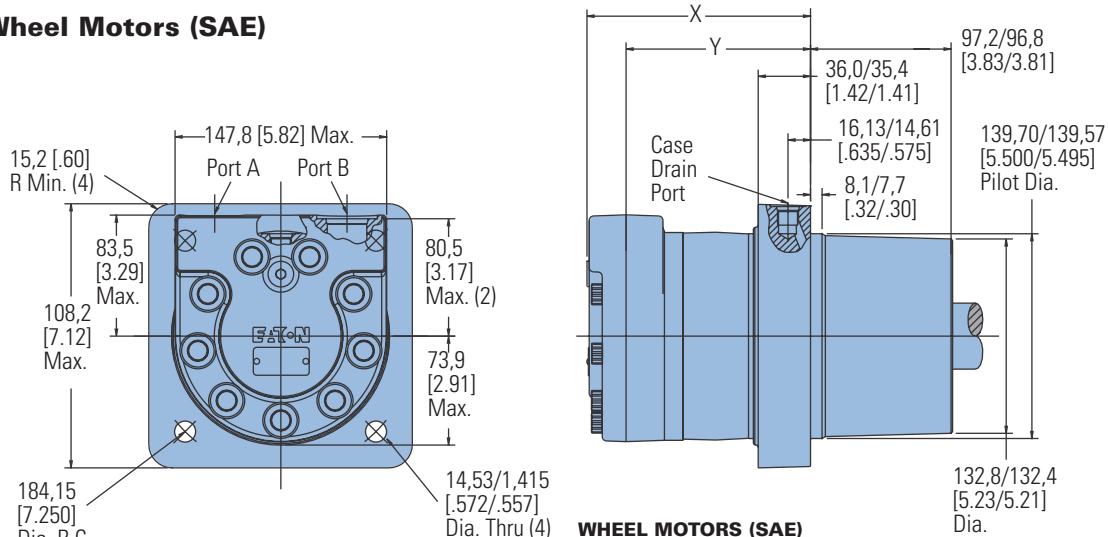

### WHEEL MOTORS (SAE)

Displacement cm <sup>3</sup> /r [in <sup>3</sup> /r]	X mm [inch]	Y mm [inch]
325 [19.8]	138,7 [5.46]	110,5 [4.35]
400 [24.4]	145,5 [5.73]	117,1 [4.61]
505 [30.7]	154,4 [6.08]	126,2 [4.97]
570 [34.9]	160,5 [6.32]	132,3 [5.21]
630 [38.5]	165,9 [6.53]	137,7 [5.42]
685 [41.7]	170,4 [6.71]	142,2 [5.60]
785 [48.0]	179,8 [7.08]	151,4 [5.96]
940 [57.4]	193,5 [7.62]	165,1 [6.50]

# VIS 40 Series

## Dimensions

Oversize Flange  
224,0 [8.82] B.C.

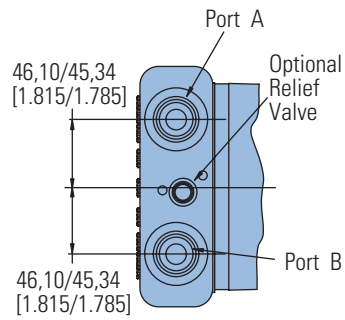

## Ports

1-1/16-12 UN-2B SAE O-ring Ports (2)

9/16-18 UNF-2B SAE O-ring Case Drain Port (1)

## Standard Rotation Viewed from Shaft End

Port A Pressurized — CW

Port B Pressurized — CCW

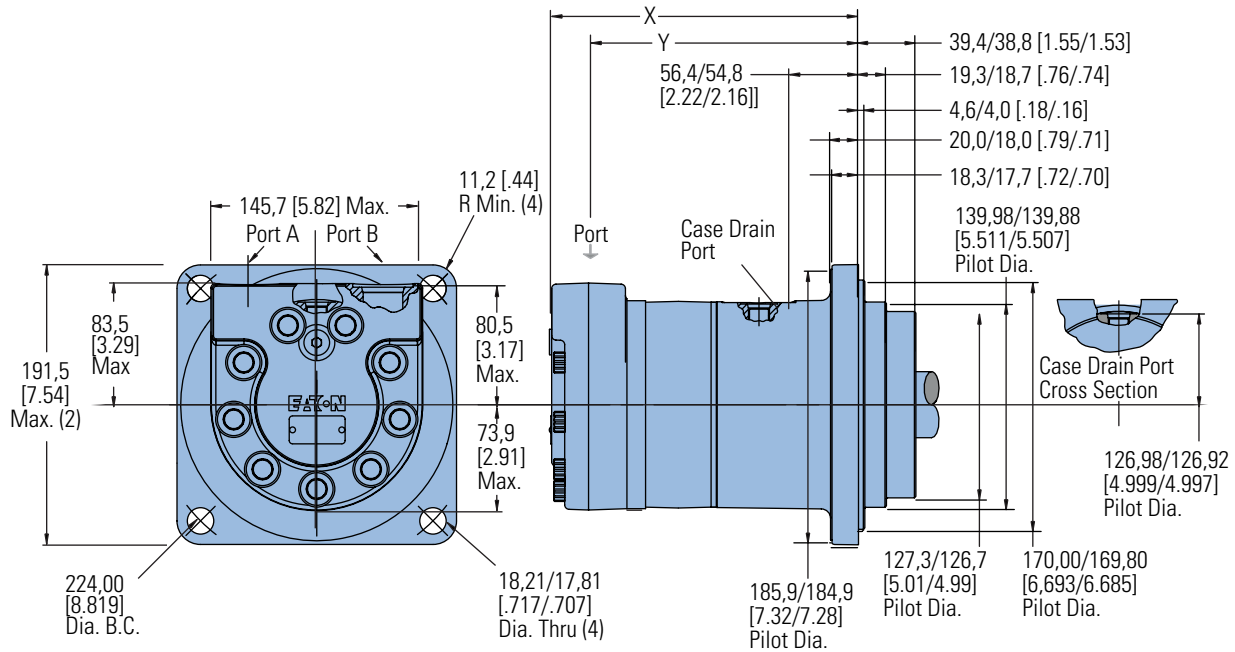

## STANDARD MOTORS (OVERSIZE)

Displacement cm <sup>3</sup> /r [in <sup>3</sup> /r]	X mm [inch]	Y mm [inch]
325 [19.8]	196,6 [7.74]	168,1 [6.62]
400 [24.4]	203,2 [8.00]	175,0 [6.89]
505 [30.7]	181,4 [8.36]	183,9 [7.24]
570 [34.9]	187,4 [8.60]	190,2 [7.49]
630 [38.5]	192,5 [8.81]	195,3 [7.69]
685 [41.7]	197,6 [8.99]	199,9 [7.87]
785 [48.0]	206,8 [9.35]	209,3 [8.24]
940 [57.4]	220,5 [9.89]	223,0 [8.78]

# VIS 40 Series

## Dimensions

Standard and Wheel Mount  
– ISO

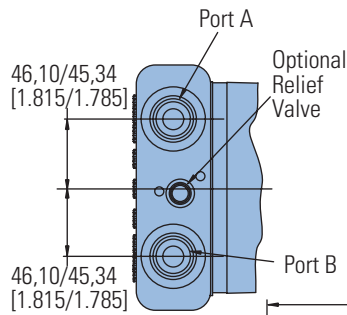

## Ports

- G 3/4 (BSP) O-ring Ports (2)
- G 1/4 (BSP) O-ring Case Drain Port (1)

## Standard Rotation Viewed from Shaft End

- Port A Pressurized — CW
- Port B Pressurized — CCW

## Standard Motors (ISO)

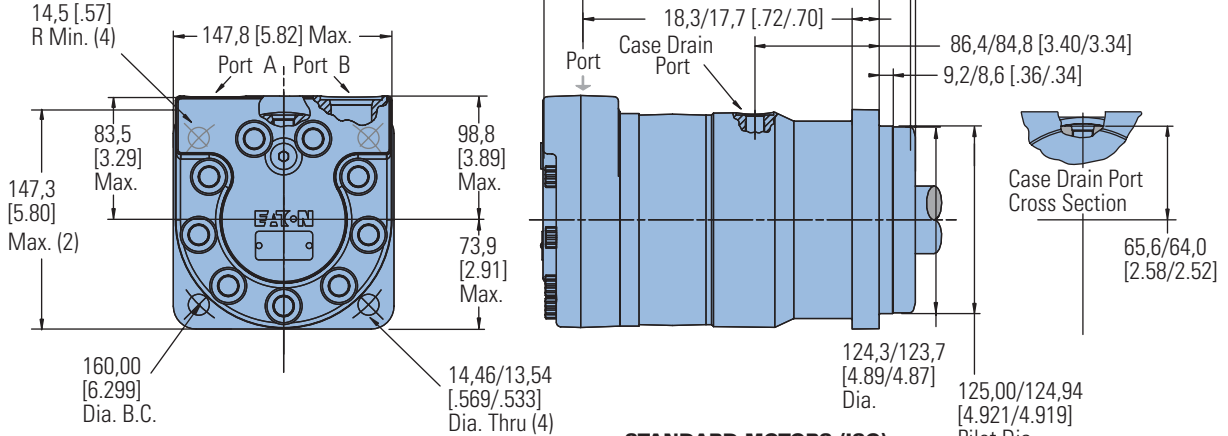

### STANDARD MOTORS (ISO)

Displacement cm <sup>3</sup> /r [in <sup>3</sup> /r]	X mm [inch]	Y mm [inch]
325 [19.8]	211,6 [8.33]	183,1 [7.21]
400 [24.4]	218,2 [8.59]	190,0 [7.48]
505 [30.7]	227,3 [8.95]	198,9 [7.83]
570 [34.9]	233,4 [9.19]	205,2 [8.08]
630 [38.5]	238,8 [9.40]	210,3 [8.28]
685 [41.7]	243,3 [9.58]	214,9 [8.46]
785 [48.0]	252,5 [9.94]	224,3 [8.83]
940 [57.4]	266,2 [10.48]	238,0 [9.37]

## Wheel Motors (ISO)

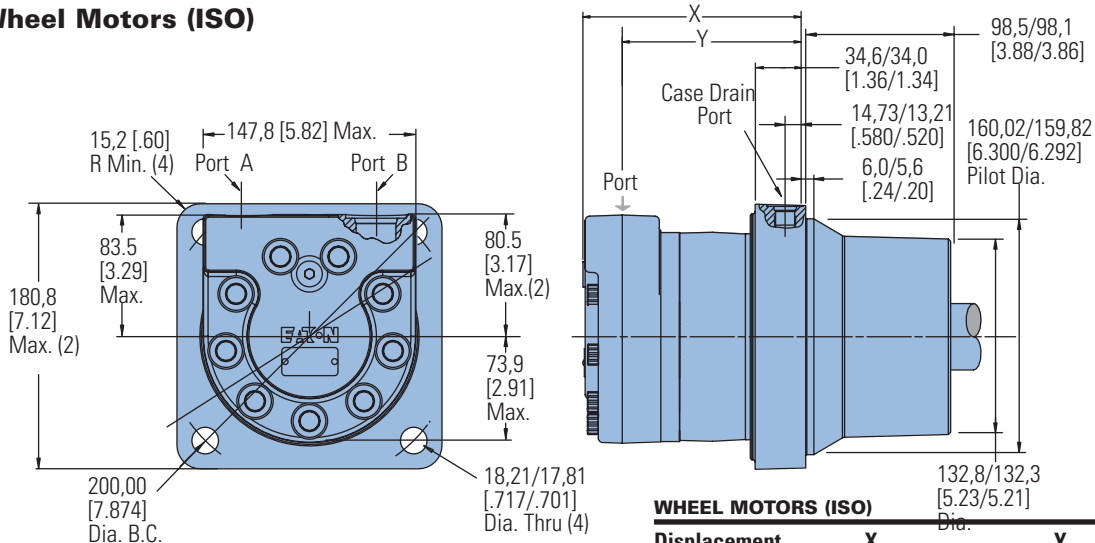

### WHEEL MOTORS (ISO)

Displacement cm <sup>3</sup> /r [in <sup>3</sup> /r]	X mm [inch]	Y mm [inch]
325 [19.8]	137,4 [5.41]	109,0 [4.29]
400 [24.4]	144,0 [5.67]	115,8 [4.56]
505 [30.7]	153,2 [6.03]	124,7 [4.91]
570 [34.9]	159,3 [6.27]	131,1 [5.16]
630 [38.5]	164,6 [6.48]	136,1 [5.36]
685 [41.7]	169,2 [6.66]	140,7 [5.54]
785 [48.0]	178,3 [7.02]	150,1 [5.91]
940 [57.4]	192,0 [7.56]	163,8 [6.45]

# VIS 40 Series

## Dimensions

Bearingless

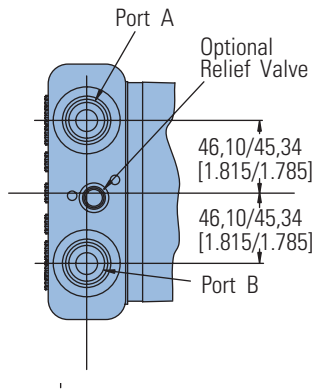

## Ports

- 1-1/16-12 UN-2B SAE O-ring Ports (2)
- 9/16-18 UNF-2B SAE O-ring Case Drain Port (1)
- Or
- G 3/4 (BSP) O-ring Ports (2)
- G 1/4 (BSP) O-ring Case Drain Port (1)

## Standard Rotation Viewed from Drive End

- Port A Pressurized — CW
- Port B Pressurized — CCW

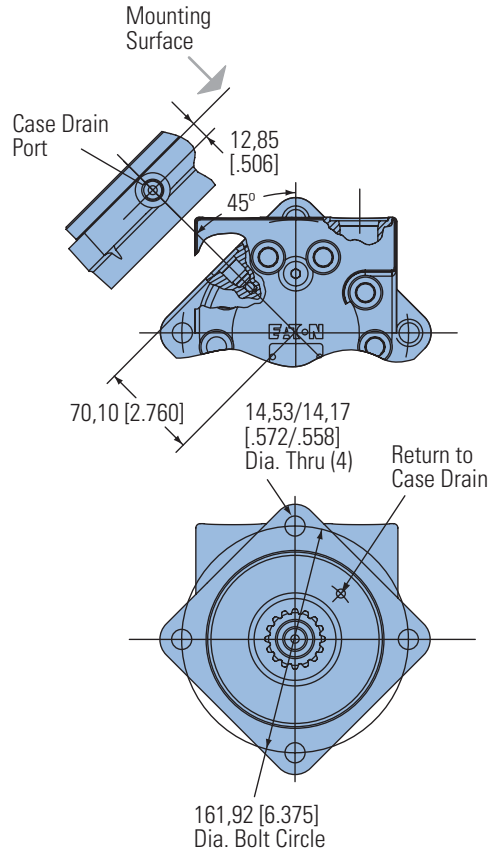
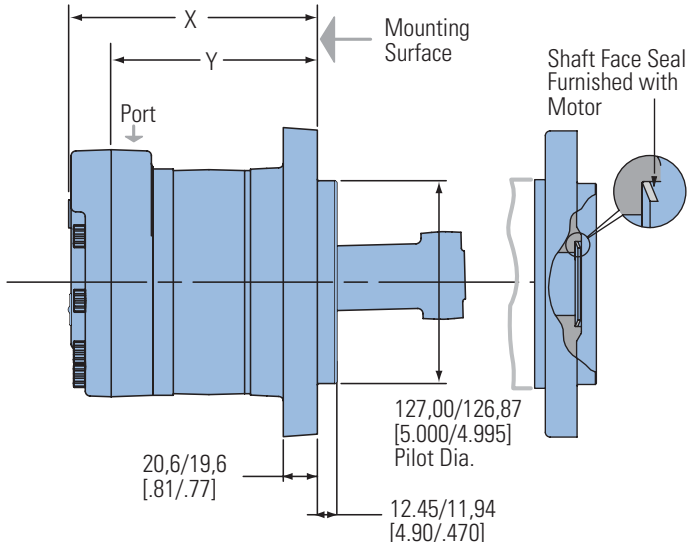

For VIS 40 bearingless motor application information, contact your Eaton representative (mating coupling blanks available from Eaton Hydraulics).

<b>C</b>	59,94	[2.36]	Dia.
<b>D</b>	49,00	[1.93]	Dia.
<b>E</b>	155,86	[6.14]	Max.
<b>F</b>	150,88	[5.94]	Min.
			Full Form Dia.
<b>G</b>	26,92	[1.06]	
<b>H</b>	33,30	[1.21]	
<b>J</b>	106,43	[4.19]	
			Full Form Dia.
<b>K</b>	72,64	[2.86]	
<b>L</b>	15		

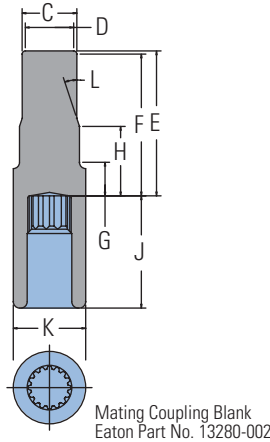

## Note:

After machining blank, part must be hardened per Eaton specification.

## BEARINGLESS MOTORS

Displacement cm <sup>3</sup> /r [in <sup>3</sup> /r]	X mm [inch]	Y mm [inch]
325 [19.8]	141,2 [5.56]	113,3 [4.46]
400 [24.4]	148,1 [5.83]	120,1 [4.73]
505 [30.7]	157,2 [6.19]	129,0 [5.08]
570 [34.9]	163,3 [6.43]	135,1 [5.32]
630 [38.5]	168,4 [6.63]	140,5 [5.53]
685 [41.7]	173,2 [6.82]	145,3 [5.72]
785 [48.0]	182,2 [7.18]	154,4 [6.08]
940 [57.4]	196,1 [7.72]	168,1 [6.62]

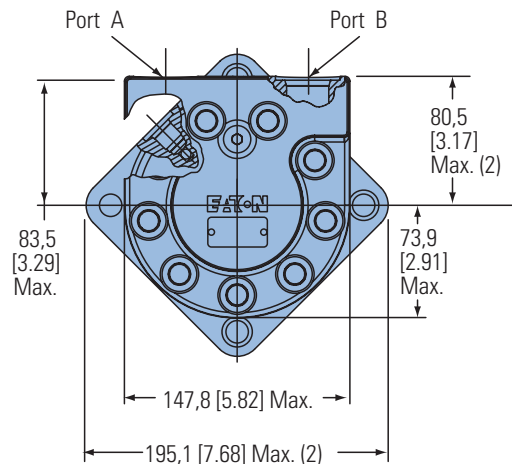

# VIS 40 Series

## Installation Information

### Bearingless

- 1 Internal spline in mating part to be per spline data. Specification material to be ASTM A304, 8620H carburize to a hardness of 60-64 HRC with case depth (to 50HRC) of 0,076 -1,27 [.030 -.050]. Dimensions apply after heat treat.
- ② Mating part to have critical dimensions as shown. Oil holes must be provided and open for proper oil circulation.
- ③ Seal to be furnished with motor for proper oil circulation thru splines.
- ④ Similar to SAE "C" Four Bolt Flange.

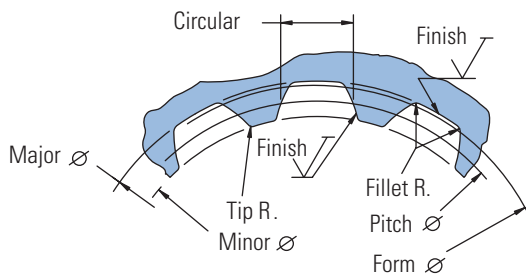
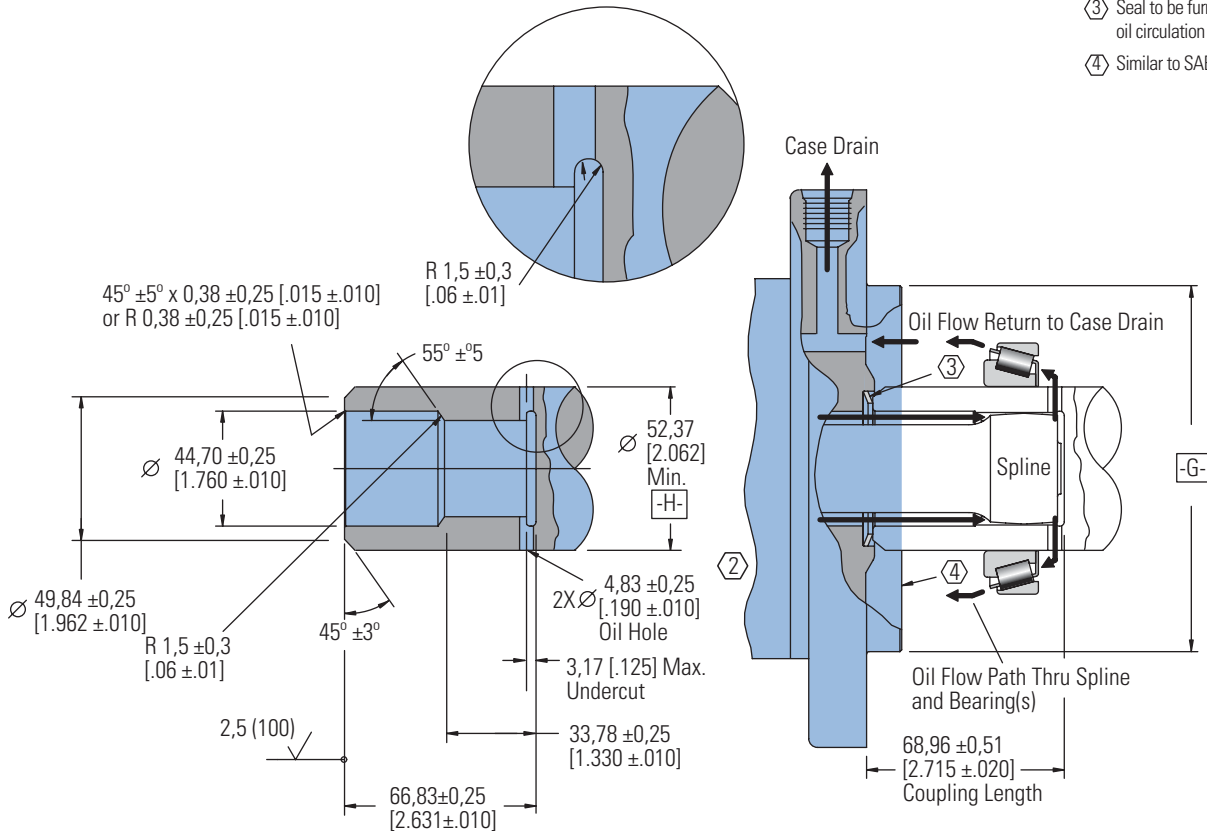

Spline Pitch.....	10/20
Pressure Angle.....	30°
Number of teeth.....	16
Class of Fit.....	Ref. 5
Type of Fit.....	Side
Pitch Diameter.....	Ref. 40,640000 [1.6000000] $\text{Ⓢ} \text{0,20} \text{ [0.008]   H}$
Base Diameter.....	Ref. 35,195272 [1.3856406]
Major Diameter.....	43,56 [1.715] Max. 43,18 [1.700]
Min. Minor Diameter.....	36,83 -37,08 [1.450 -1.460]
Form Diameter, Min.....	42,47 [1.672]
Fillet Radius.....	0,64 -0,76 [.025 -0.030]
Tip Radius.....	0,25 -0,51 [.010 -0.020]
Finish.....	1,6 (63)
Involute Profile Variation.....	+0,000 -0,025 [+0.0000 -0.0010]
Total Index Variation.....	0,040 [0.016]
Lead Variation.....	0,013 [0.0005]
Circular Space Width:	
Maximum Actual.....	4,105 [1.6116]
Minimum Effective.....	3,995 [1.573]
Maximum Effective.....	Ref. 4,056 [1.597]
Minimum Actual.....	Ref. 4,081 [1.582]
Dimension Between Two Pins.....	Ref. 34,272 -34,450 [1.3493 -1.3563]
Pin Diameter.....	4,389 [1.728]

# VIS 40 Series

Dimensions Shafts

SAE

## 40 mm Straight

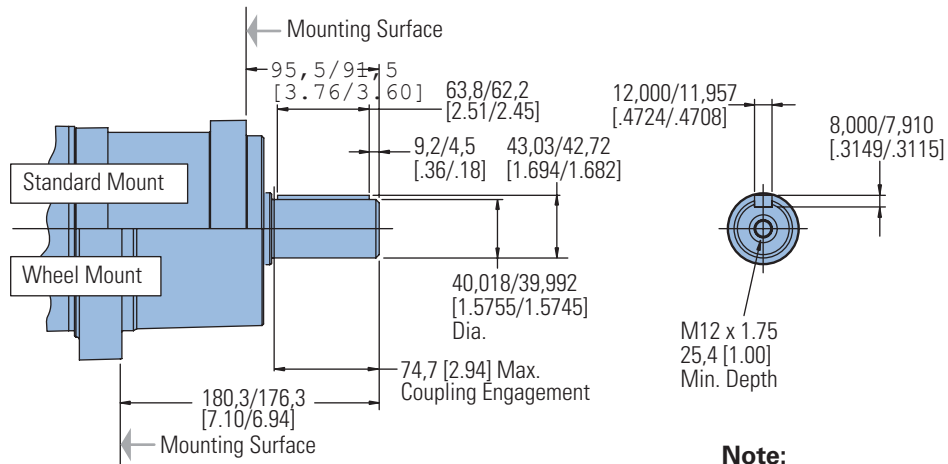

**Note:**

For motor torque ratings above 875 Nm [7750 lb - in] use split coupler.

## 1-1/2 Inch 17 Tooth Splined

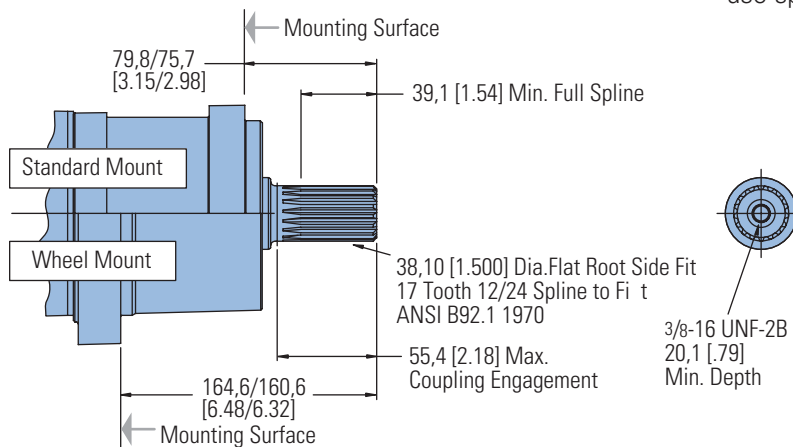

## 1-3/4 Inch Tapered

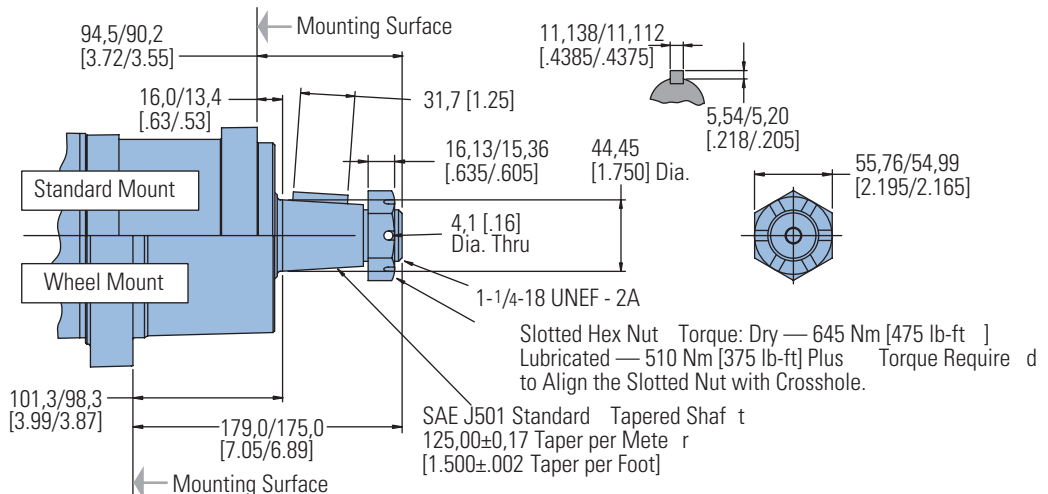

# VIS 40 Series

## Side Load Capacity

SAE

These curves indicate the radial load capacity on the motor shaft(s) at various locations.

**The curve is based on B 10 bearing life (2000 hours of 12,000,000 shaft revolutions at 100 RPM) at rated output torque.**

To determine radial load at speeds other than 100 RPM, multiply the load values given on the bearing curve by the factors in the chart below.

RPM	Multiplication Factor
50	1.23
100	1.00
200	0.81
300	0.72
400	0.66
500	0.62
600	0.58
700	0.56
800	0.54

For 3,000,000 shaft revolutions or 500 hours — Increase these shaft loads 52%.

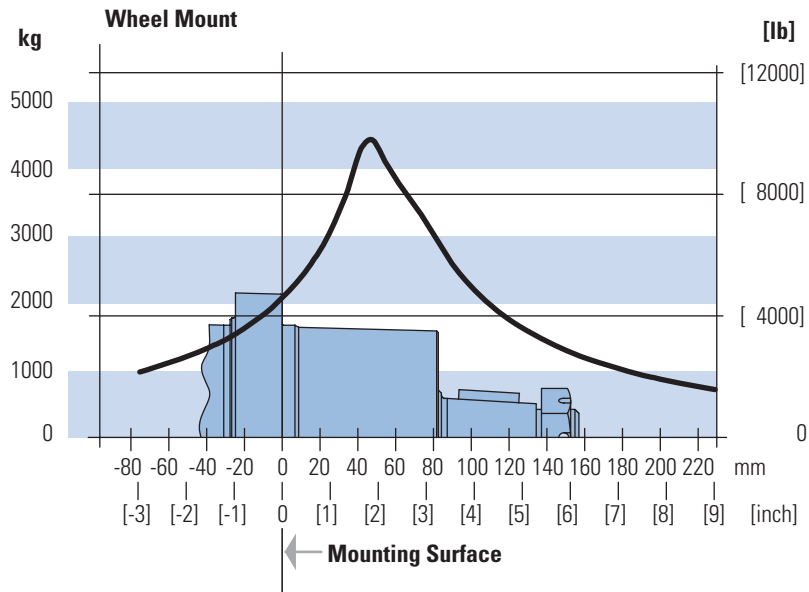
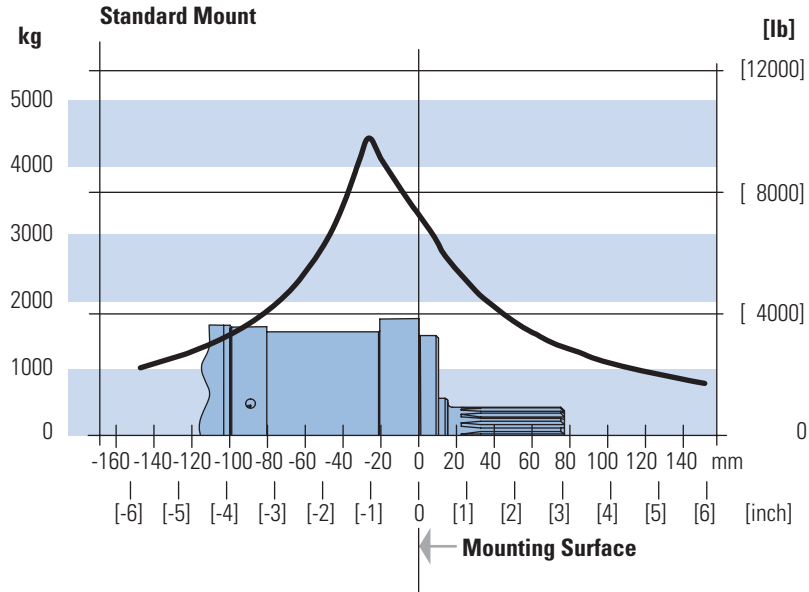

# VIS 40 Series

## Dimensions Shafts

Oversize Flange  
224,0 [8.82] B.C.

### 40 mm Straight

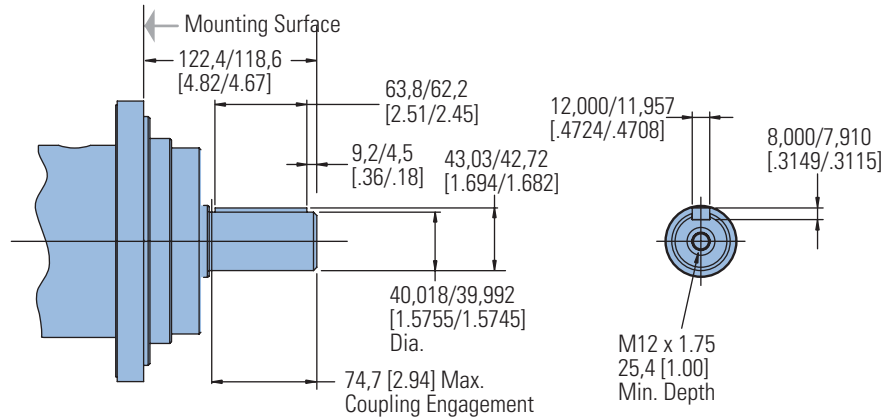

#### Note:

For motor torque ratings above 875 Nm [7750 lb - in] use split coupler.

### 46 mm 28 Tooth Splined

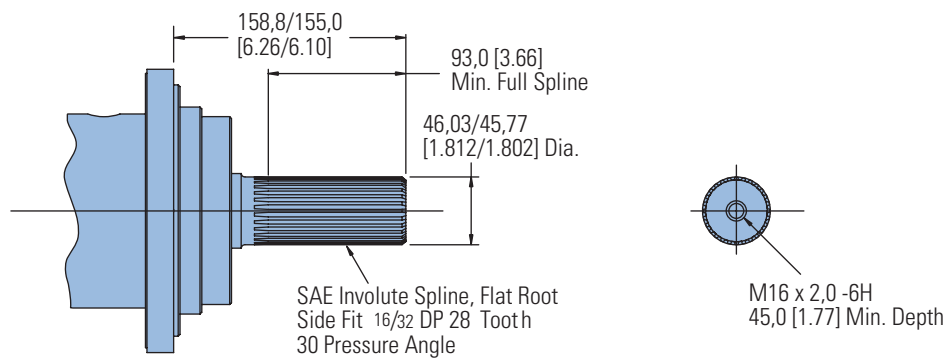

### 1-3/4 Inch Tapered

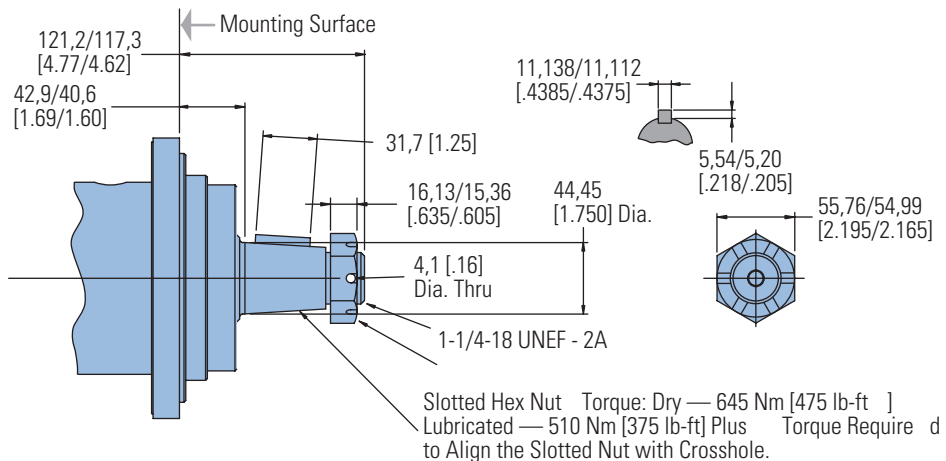

SAE J501 Standard Tapered Shaft  
125,00±0,17 Taper per Meter  
[1.500±.002 Taper per Foot]



# VIS 40 Series

## Side Load Capacity

Oversize Flange  
224,0 [8.82] B.C.

These curves indicate the radial load capacity on the motor shaft(s) at various locations.

**The curve is based on B 10 bearing life (2000 hours of 12,000,000 shaft revolutions at 100 RPM) at rated output torque.**

To determine radial load at speeds other than 100 RPM, multiply the load values given on the bearing curve by the factors in the chart below.

RPM	Multiplication Factor
50	1.23
100	1.00
200	0.81
300	0.72
400	0.66
500	0.62
600	0.58
700	0.56
800	0.54

For 3,000,000 shaft revolutions or 500 hours — Increase these shaft loads 52%.

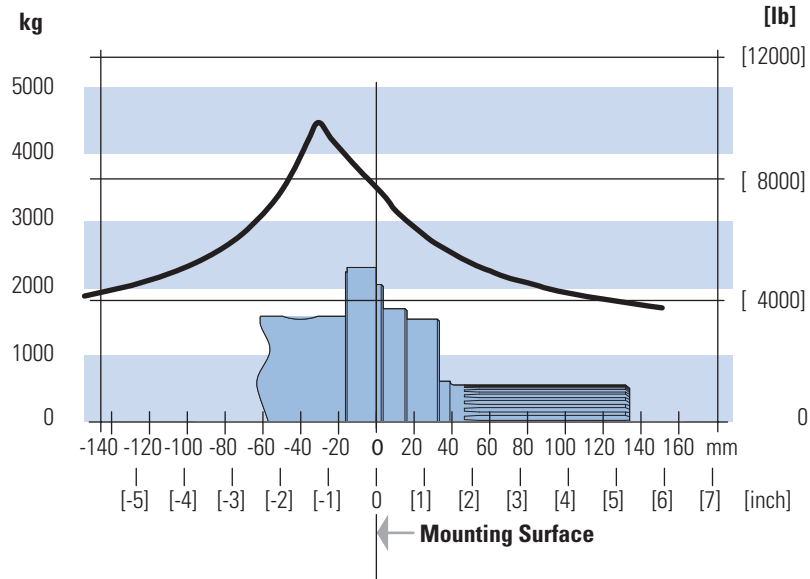

# VIS 40 Series

Dimensions

Shafts

ISO

## 40 mm Straight

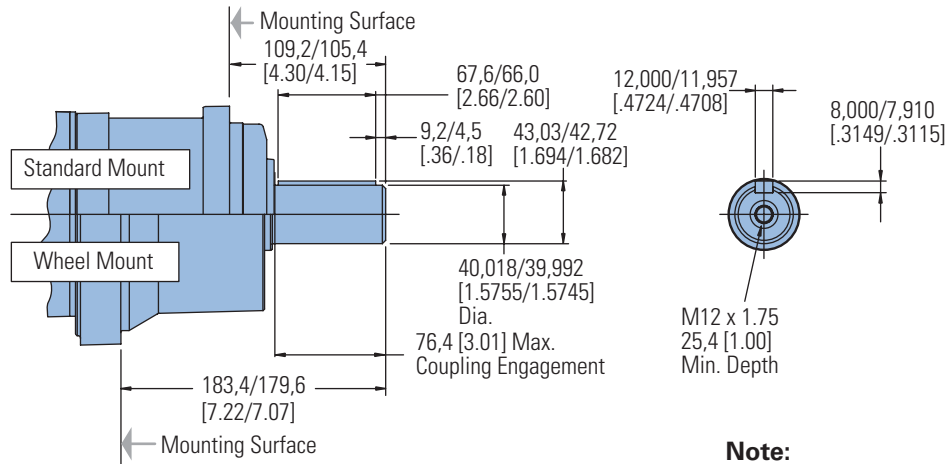

### Note:

For motor torque ratings above 875 Nm [7750 lb - in] use split coupler.

## 38,1 mm [1-1/2 inch] 17 Tooth Splined

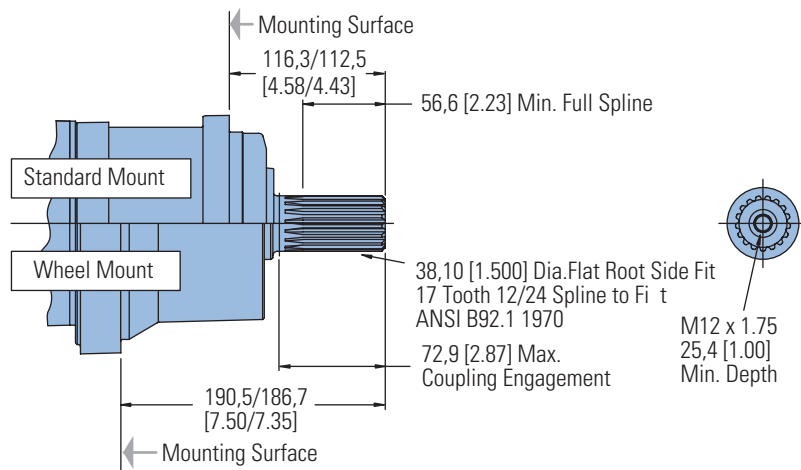

## 45 mm Tapered

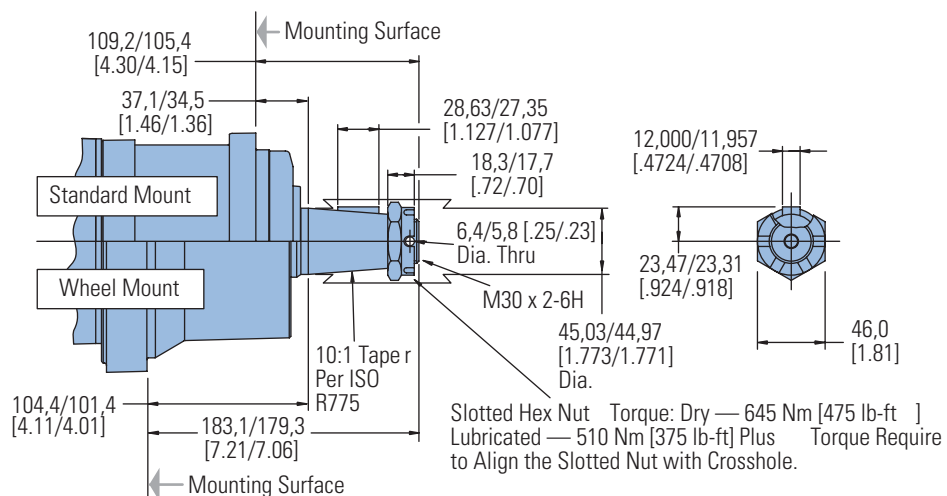

# VIS 40 Series

## Side Load Capacity

ISO

These curves indicate the radial load capacity on the motor shaft(s) at various locations.

**The curve is based on B 10 bearing life (2000 hours of 12,000,000 shaft revolutions at 100 RPM) at rated output torque.**

To determine radial load at speeds other than 100 RPM, multiply the load values given on the bearing curve by the factors in the chart below.

RPM	Multiplication Factor
50	1.23
100	1.00
200	0.81
300	0.72
400	0.66
500	0.62
600	0.58
700	0.56
800	0.54

For 3,000,000 shaft revolutions or 500 hours — Increase these shaft loads 52%.

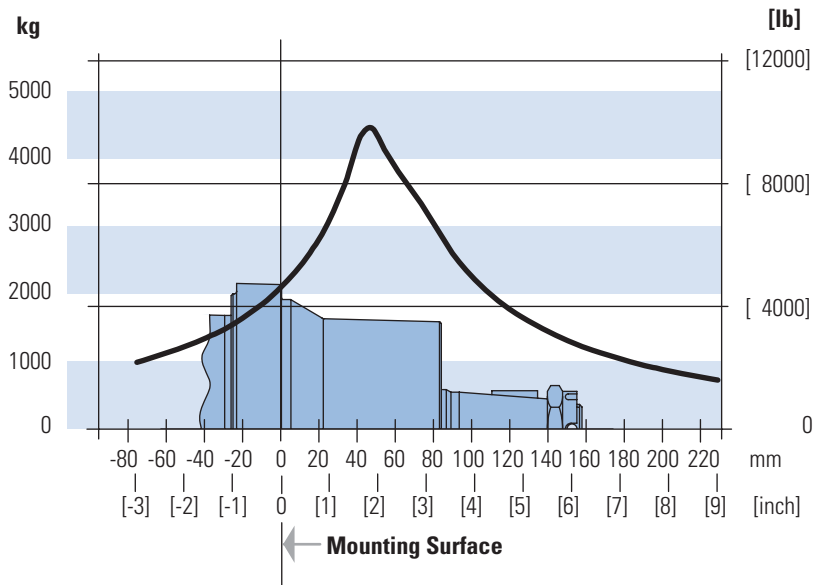
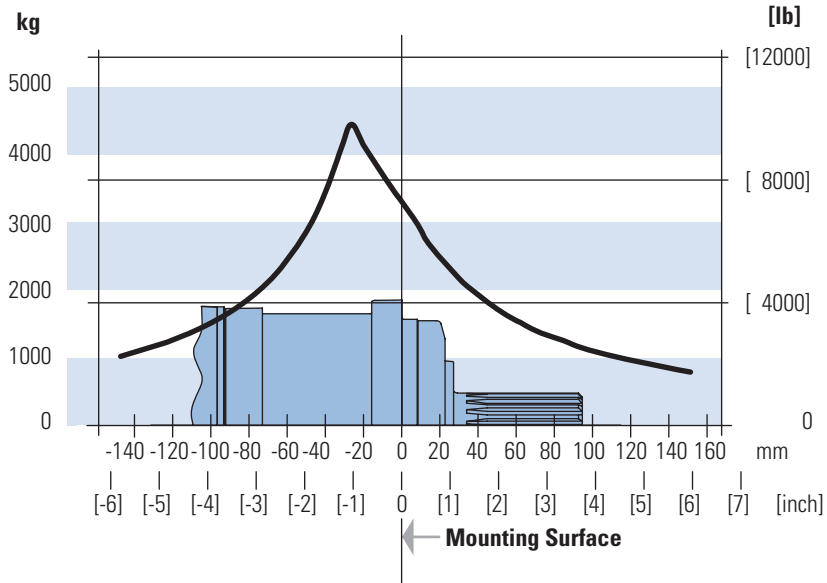

# VIS 40 Series

Product Numbers

Closed Loop

Use digit prefix — 168-, 177-, or 180- plus four digit number from charts for complete product number— Example: 168-0018.

**Orders will not be accepted without three digit prefix.**

## SAE

MOUNTING	SHAFT	PORT SIZE	DISPL. cm <sup>3</sup> /r [in <sup>3</sup> /r] / PRODUCT NUMBER								
			325 [19.8]	400 [24.4]	505 [30.7]	570 [34.9]	630 [38.5]	685 [41.7]	785 [48.0]	940 [57.4]	
Standard	40 mm Straight	1 1/16 -12 UNF O-ring (2) 9/16 -18 UNC Drain Port (1)	177-0220	-0218	-0032	-0022	-0033	-0034	-0035	-0036	
	1 1/2 inch 17 Tooth Splined	1 1/16 -12 UNF O-ring (2) 9/16 -18 UNC Drain Port (1)	177-0221	—	-0024	-0026	-0037	-0038	-0039	-0040	
	1 3/4 inch Tapered	1 1/16 -12 UNF O-ring (2) 9/16 -18 UNC Drain Port (1)	—	—	-0041	-0042	-0043	-0044	-0045	-0046	
Wheel	40 mm Straight	1 1/16 -12 UNF O-ring (2) 9/16 -18 UNC Drain Port (1)	—	—	-0007	-0008	-0009	-0010	-0011	-0012	
	1 1/2 inch 17 Tooth Splined	1 1/16 -12 UNF O-ring (2) 9/16 -18 UNC Drain Port (1)	—	—	-0013	-0014	-0015	-0016	-0017	-0018	
	1 3/4 inch Tapered	1 1/16 -12 UNF O-ring (2) 9/16 -18 UNC Drain Port (1)	—	180-0088	-0019	-0020	-0021	-0022	-0023	-0024	
Bearingless		1 1/16 -12 UNF O-ring (2) 9/16 -18 UNC Drain Port (1)	—	—	-0015	-0016	-0017	-0018	-0019	-0020	

168-0018

## Overize

MOUNTING	SHAFT	PORT SIZE	DISPL. cm <sup>3</sup> /r [in <sup>3</sup> /r] / PRODUCT NUMBER								
			325 [19.8]	400 [24.4]	505 [30.7]	570 [34.9]	630 [38.5]	685 [41.7]	785 [48.0]	940 [57.4]	
Standard	40 mm Straight	1 1/16 -12 UNF O-ring (2) 9/16 -18 UNC Drain Port (1)	—	—	177-0047	-0048	—	—	—	—	
	46 mm 28 Tooth Splined	1 1/16 -12 UNF O-ring (2) 9/16 -18 UNC Drain Port (1)	—	—	177-0053	-0054	—	—	—	—	
	1 3/4 inch Tapered	1 1/16 -12 UNF O-ring (2) 9/16 -18 UNC Drain Port (1)	—	—	177-0059	-0060	—	—	—	—	

## ISO

MOUNTING	SHAFT	PORT SIZE	DISPL. cm <sup>3</sup> /r [in <sup>3</sup> /r] / PRODUCT NUMBER								
			325 [19.8]	400 [24.4]	505 [30.7]	570 [34.9]	630 [38.5]	685 [41.7]	785 [48.0]	940 [57.4]	
Standard	40 mm Straight	G 3/4 (BSP) (2) G 1/4 (BSP) Drain Port (1)	—	—	-0065	-0066	-0067	-0068	-0069	-0070	
	45 mm Tapered	G 3/4 (BSP) (2) G 1/4 (BSP) Drain Port (1)	177-0223	-0224	-0071	-0072	-0073	-0074	-0075	-0076	
	1 1/2 inch 17 Tooth Splined	G 3/4 (BSP) (2) G 1/4 (BSP) Drain Port (1)	—	—	-0077	-0078	-0079	-0080	-0081	-0082	
Wheel	40 mm Straight	G 3/4 (BSP) (2) G 1/4 (BSP) Drain Port (1)	—	—	-0025	-0026	-0027	-0028	-0029	-0030	
	45 mm Tapered	G 3/4 (BSP) (2) G 1/4 (BSP) Drain Port (1)	—	—	-0031	-0032	-0033	-0034	-0035	-0036	
	1 1/2 inch 17 Tooth Splined	G 3/4 (BSP) (2) G 1/4 (BSP) Drain Port (1)	—	—	-0037	-0038	-0039	-0040	-0041	-0042	
Bearingless		G 3/4 (BSP) (2) G 1/4 (BSP) Drain Port (1)	—	—	-0021	-0022	-0023	-0024	-0025	-0026	

168-0024

### Note:

The product numbers on this page are for motors used in closed loop circuits. They include a back-pressure relief valve that is set at 4,5 bar [65 PSI].

- A case drain is required for all closed loop VIS motor applications.
- The maximum case pressure for the VIS motor is 3,5 bar [50 PSI].

# VIS 40 Series

## Model Code

The following 16 - digit coding system has been developed to identify all of the configuration options for the VIS 40 motor. Use this model code to specify a motor with the desired features. All 16 digits of the code must be present when ordering. You may want to photocopy the matrix below to ensure that each number is entered in the correct box.

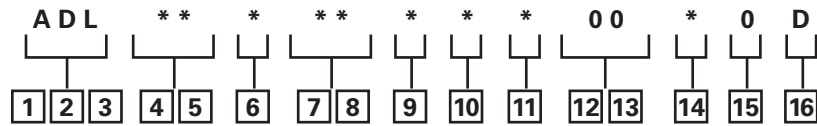

**1, 2, 3 Product Series**  
ADL – VIS 40 Motor

**4, 5 Displacement**  
cm<sup>3</sup>/r [in<sup>3</sup>/r]

- 20 – 325 [19.8]
- 24 – 400 [24.4]
- 31 – 505 [30.7]
- 35 – 570 [34.9]
- 38 – 630 [38.5]
- 42 – 685 [41.7]
- 48 – 785 [48.0]
- 57 – 940 [57.4]

**6 Mounting Type**

**A** – 4 Bolt Bearingless  
127,00 [5.000] Pilot Dia. with  
12,19 [.480] Pilot Length  
and 14,35 [.565] Dia holes  
on 161,92 [6.375] Dia. Bolt  
Circle

**B** – 4 Bolt Wheel Mount  
160,00 [6.3] Pilot Dia. With  
5,8 [.23] Pilot Length and  
18,00 [.709] Dia. Holes on  
200,00 [7.874] Dia. Bolt  
Circle (ISO Compatible)

**C** – 4 Bolt Oversize Flange  
185,4 [7.30] Rear Pilot Dia.,  
169,90 [6.689], 139,93  
[5.509], 127,0 [5.00] Dia  
(Front Pilots) and 18,01  
[.709] Dia. Holes on 224,00  
[8.819] Dia. Bolt Circle

**F** – 4 Bolt Standard Mount  
(SAE CC) 127,00 [5.000] Pilot  
Dia. With 12,2 [.48] Pilot  
Length and 14,32 [.564] Dia.  
Holes on 161,92 [6.375] Dia.  
Bolt Circle

**G** – 4 Bolt Wheel Mount  
139,7 [5.50] Pilot Dia. with  
7,9 [.31] Pilot Length and  
14,32 [.564] Dia. Holes on  
184,15 [7.250] Dia. Bolt  
Circle (SAE Compatible)

**H** – 4 Bolt Standard Mount  
125,00 [4.92] Pilot Dia. with  
8,9 [.35] Pilot Length and  
14,00 [.551] Dia. Holes on

160,00 [6.299] Dia. Bolt  
Circle (ISO Compatible)

**M** – Standard, 4 Bolt: 169,75  
[6.683] Pilot Dia. with 4,3  
[.17] Pilot Length and M16  
X 2 -6H Threaded Holes  
on 224,00 [8.819] Dia. Bolt  
Circle (To be selected for  
Brake Option)

**7, 8 Output Shaft**

**00** – None (Bearingless)

**01** – 45 mm Dia. 10:1  
Tapered Shaft Per ISO R775  
with M30 x 2- 6H Threaded  
Shaft End, 12W x 8H x 28L  
[.472W x .313H x 1.102L]  
Key

**02** – 1-3/4 inch Dia. .125:1  
Tapered Shaft Per SAE J 501  
with 1 1/4 - 18 UNEF - 2A  
Threaded Shaft End, 11,11  
[.4375] Square x 31,8 [1.25]  
Straight Key

**04** – 46 mm Dia. Flat Root  
Side Fit, 28 Tooth, 16/32 DP  
30 Degree Involute Spline,  
93,0 [3.66] Minimum Full  
Spline with M16 X 2,0-6H  
Thread in End

**07** – 40 mm Dia. Straight  
Shaft with M12 x 1,75 -  
6H Thread in End, 12W  
x 8H x 63L [.472W x  
.313H x 2.480L] Key (SAE  
Compatible)

**08** – 1-1/2 inch Dia. Flat  
Root Side Fit, 17 Tooth,  
12/24 DP 30 Degree Involute  
Spline, 39,1 [1.54] Minimum  
Full Spline with 3/8-16 UNC  
- 2B Thread in End (SAE  
Compatible)

**09** – 1-1/2 inch Dia. Flat  
Root Side Fit, 17 Tooth,  
12/24 DP 30 Degree Involute  
Spline, 56,6 [2.23] Minimum  
Full Spline with M12 x 1.75  
- 6H Thread in End (ISO  
Compatible)

**10** – 40 mm Dia. Straight  
Shaft with M12 x 1,75 -  
6H Thread in End, 12W  
x 8H x 67L [.472W x  
.313H x 2.630L] Key (ISO  
Compatible)

**9 Ports**

**A** – 1-1/16-12 UN-2B Size 12  
O-ring Port, Accepts Fittings  
for SAE J1926

**B** – G 3/4 (BSP) Straight  
Thread Port

**10 Case Flow Options**

**A** – Shuttle Valve with  
9/16-18 UNF-2B, Size 6 O-ring  
Port Case Drain, Accepts  
Fittings for SAE J1926

**B** – Shuttle Valve with G 1/4  
(BSP) Straight Thread Port  
Case Drain

**C** – Check valve with  
leakage orifice, no case  
drain (for Open Loop only)

**11 Back-Pressure Relief**

**0** – None (for Open Loop  
Only)

**1** – Set at 4,5 bar [65 PSI]  
(for Manual Pumps)

**2** – Set at 15,2 bar [220 PSI]  
(for Servo Pumps)

**4** – Set at 15,2 bar [300 PSI]  
(for high charge Servo  
Pumps)

**12, 13 Special Features**

**00** – None

**08** – Spring Applied  
Hydraulic Release Wet Brake  
with Brake Capacity of  
20,000 lbf-in Static and 150  
lbf/in<sup>2</sup> release pressure

**14 Paint/ Special  
Packaging**

**0** – Primer, Individual Box

**A** – Low Gloss Black Primer,  
Individual Box

**B** – No Paint, Bulk Box  
Option

**C** – Low Gloss Black Primer,  
Bulk Box Option

**15 Eaton Assigned  
Code when Applicable**

**0** – Assigned Code

**16 Eaton Assigned  
Design Code**

**D** – Assigned Design Code

# VIS 40 Series Two-speed

## Specifications

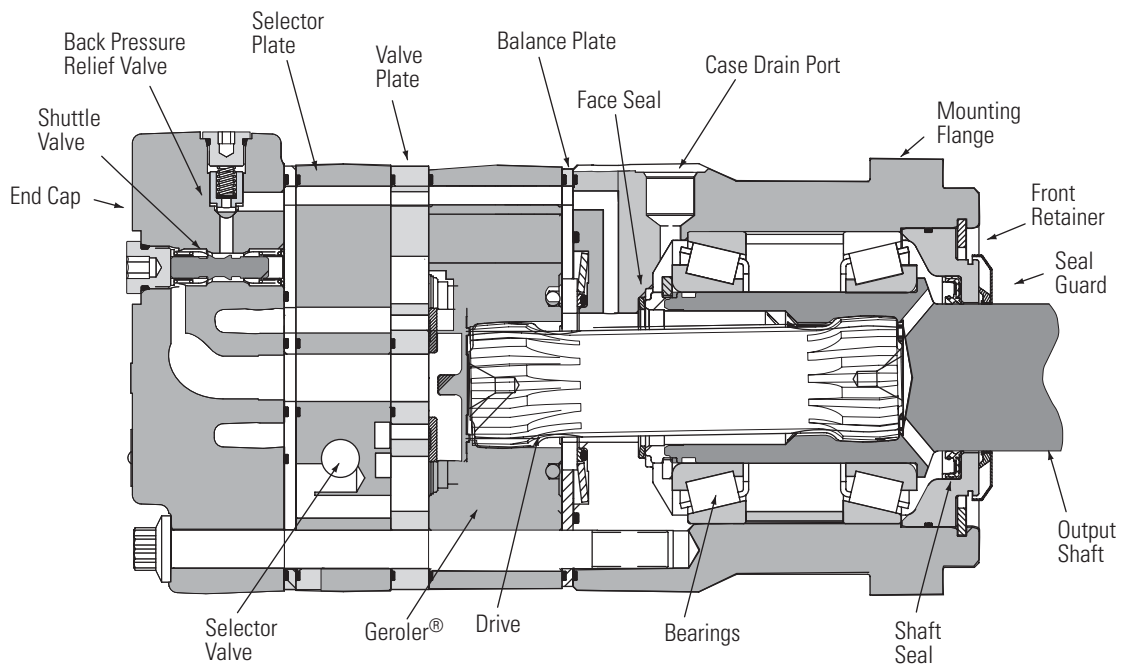

VIS 40 Series motors are available with an integral two-speed feature that allows the operator to shift the motor between low speed high torque (LSHT) mode and high speed low torque (HSLT) mode.

In the LSHT mode, output torque and rotation speed values are equal to those of the conventional VIS 40 motor. In the HSLT mode motor displacement is reduced by one third, resulting in a fifty percent increase in rotation speed and a torque output reduction of one third.

The VIS 40 two-speed motor is bidirectional. It will function with equal shaft output in either rotation

direction (CW or CCW) in both LSHT and HSLT modes. Shift on the fly technology allows full-power operation throughout the full duration of the shift.

Changing between modes is accomplished by changing the displacement in a ratio of 1 to 1.5. An external two-position three-way control valve is required for shifting pressure to the pilot port between low pressure (LSHT mode) and pilot signal pressure (HSLT mode).

An integral selector valve shifts the motor from LSHT mode to HSLT mode. Initially, low pressure is supplied to the pilot port. The selector valve is biased to LSHT mode by a return spring. When pilot signal pressure is supplied to the

pilot port and 3,5  $\Delta$ bar [50 PSI] is reached, the selector valve overcomes return spring force and the shifts the spool to select HSLT mode.

Oil on the opposite side of the spool is drained to tank via the drain port. The pressure difference between the pilot port and drain port must be maintained to keep the motor in the high speed mode. When pilot pressure is removed from the pilot port, the pressure in the pilot end of the spool valve is relieved and drained back through the control valve and the return spring forces the spool valve to LSHT position.

Pilot pressure may come from any source that will provide uninterrupted pressure during the high-speed mode operation. Allowable pilot pressure must be at least 3,5  $\Delta$ bar [50 PSI] and may be as high as full operating pressure of the motor.

All VIS 40 Series two-speed motors are equipped with a return line shuttle for closed circuit applications as standard equipment. All options available on the conventional VIS 40 are also available on VIS 40 two-speed motors.

## Performance Data

In the LSHT mode, torque and speed values are equal to those of the conventional VIS 40 motor. In the HSLT mode, rotation speed is increased by fifty percent and torque output is reduced by one third. The VIS 40 two-speed motor will function with equal shaft output in either rotation direction (CW or CCW) in both LSHT and HSLT modes.

# VIS 40 Series

## Two-speed

### Dimensions

Standard and Wheel Mount  
– SAE

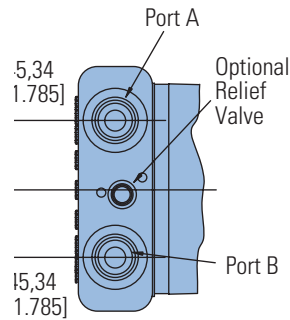

### Ports

- 1–1/16-12 UN-2B SAE O-ring Ports (2)
- 9/16-18 UNF-2B SAE O-ring Case Drain Port (1)
- 7/16 -20 UNF -2B SAE O-ring Shift Ports (2)

### Standard Rotation Viewed from Shaft End

- Port A Pressurized — CW
- Port B Pressurized — CCW

### Standard Motors (SAE)

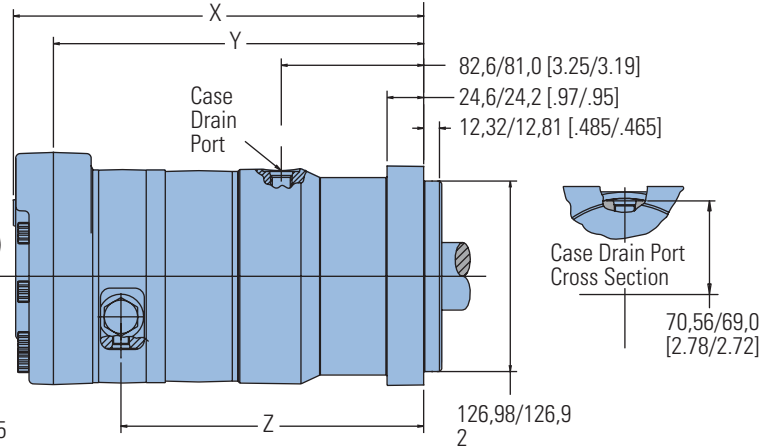
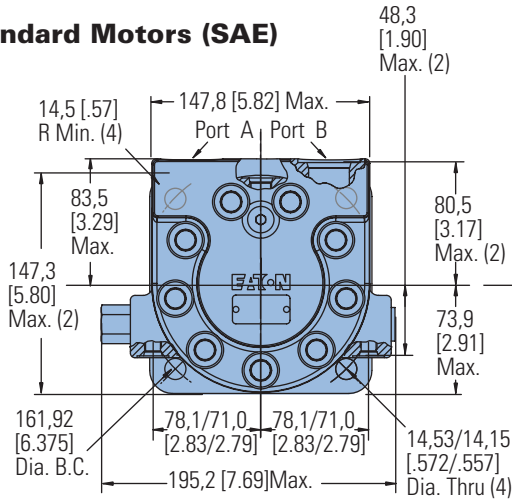

### STANDARD MOTORS (SAE)

Displacement cm <sup>3</sup> /r [in <sup>3</sup> /r]	X mm [inch]	Y mm [inch]	Z mm [inch]
325 [19.8]	259,3 [10.21]	231,4 [9.11]	186,2 [7.33]
400 [24.4]	265,9 [10.47]	238,0 [9.37]	193,0 [7.60]
505 [30.7]	275,1 [10.83]	246,9 [9.72]	201,7 [7.94]
570 [34.9]	281,2 [11.07]	253,0 [9.96]	208,0 [8.19]
630 [38.5]	286,3 [11.27]	258,3 [10.17]	213,4 [8.40]
685 [41.7]	290,8 [11.45]	262,9 [10.35]	217,7 [8.57]
785 [48.0]	300,2 [11.82]	272,3 [10.72]	227,3 [8.95]
940 [57.4]	313,9 [12.36]	286,0 [11.26]	241,0 [9.49]

### Wheel Motors (SAE)

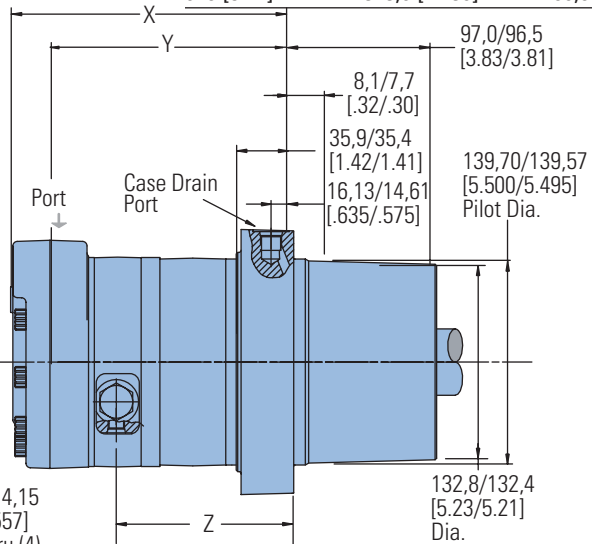
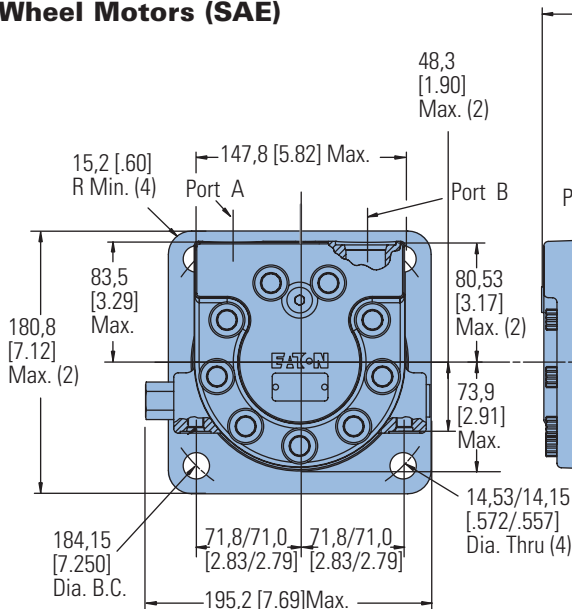

### WHEEL MOTORS (SAE)

Displacement cm <sup>3</sup> /r [in <sup>3</sup> /r]	X mm [inch]	Y mm [inch]	Z mm [inch]
325 [19.8]	174,5 [6.87]	146,6 [5.77]	101,3 [3.99]
400 [24.4]	181,1 [7.13]	153,2 [6.03]	108,2 [4.26]
505 [30.7]	190,2 [7.49]	162,1 [6.38]	116,8 [4.60]
570 [34.9]	196,3 [7.73]	168,1 [6.62]	123,2 [4.85]
630 [38.5]	201,4 [7.93]	173,5 [6.83]	128,5 [5.06]
685 [41.7]	206,0 [8.11]	178,1 [7.01]	132,8 [5.23]
785 [48.0]	215,4 [8.48]	187,5 [7.38]	142,5 [5.61]
940 [57.4]	229,1 [9.02]	201,2 [7.92]	156,2 [6.15]

# VIS 40 Series

## Two-speed

### Dimensions

Oversize Flange  
224,0 [8.82] B.C.

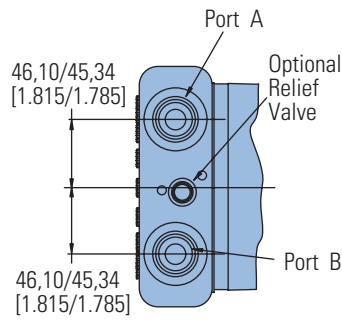

### Ports

- 1-1/16-12 UN-2B SAE O-ring Ports (2)
- 9/16-18 UNF-2B SAE O-ring Case Drain Port (1)
- 7/16 -20 UNF -2B SAE O-ring Shift Ports (2)

### Standard Rotation Viewed from Shaft End

- Port A Pressurized — CW
- Port B Pressurized — CCW

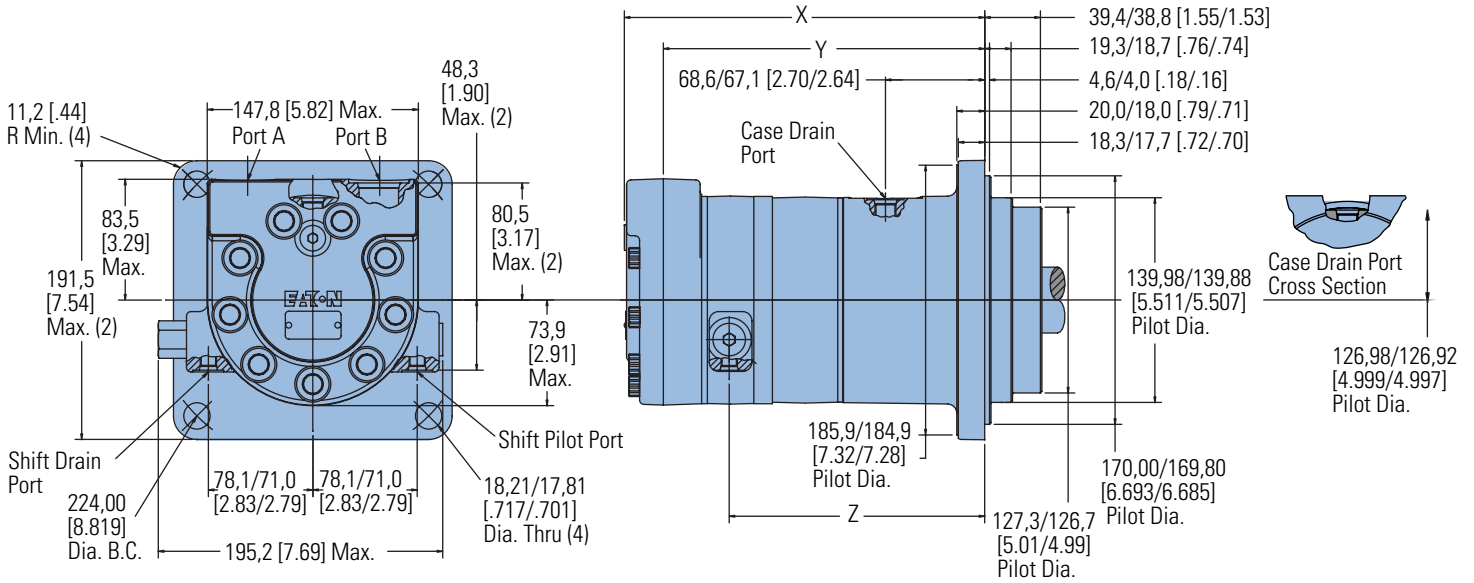

### OVERSIZE MOTORS

Displacement cm <sup>3</sup> /r [in <sup>3</sup> /r]	X mm [inch]	Y mm [inch]	Z mm [inch]
325 [19.8]	232,4 [9.15]	204,0 [8.03]	159,0 [6.26]
400 [24.4]	239,3 [9.42]	210,6 [8.29]	165,6 [6.52]
505 [30.7]	248,2 [9.77]	220,0 [8.66]	174,8 [6.88]
570 [34.9]	254,3 [10.01]	226,1 [8.90]	181,1 [7.13]
630 [38.5]	259,3 [10.21]	231,4 [9.11]	186,4 [7.34]
685 [41.7]	263,9 [10.39]	236,0 [9.29]	190,8 [7.51]
785 [48.0]	273,1 [10.75]	245,1 [9.65]	200,2 [7.88]
940 [57.4]	286,8 [11.29]	258,8 [10.19]	213,9 [8.42]



# VIS 40 Series

## Two-speed

### Dimensions

Standard and Wheel Mount  
– ISO

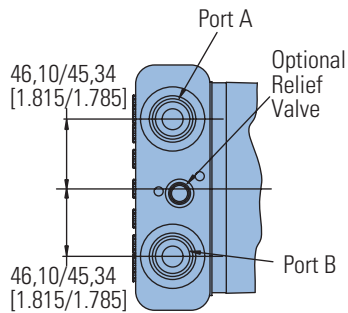

### Ports

- G 3/4 (BSP) O-ring Ports (2)
- G 1/4 (BSP) O-ring Case Drain Port (1)
- 7/16 -20 UNF -2B SAE O-ring Shift Ports (2)

### Standard Rotation Viewed from Shaft End

- Port A Pressurized — CW
- Port B Pressurized — CCW

### Standard Motors (ISO)

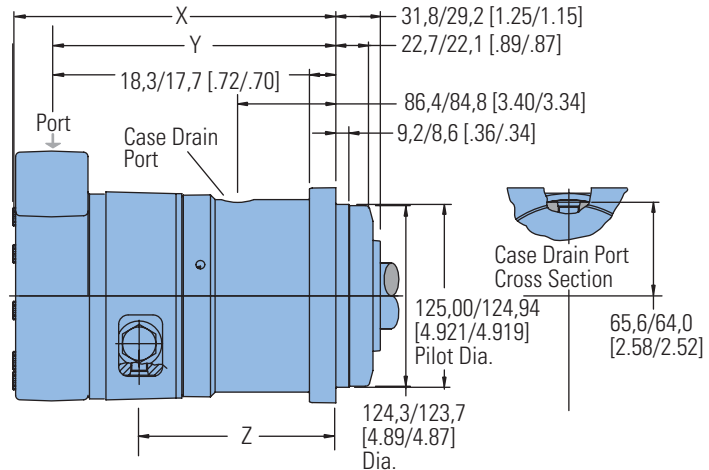
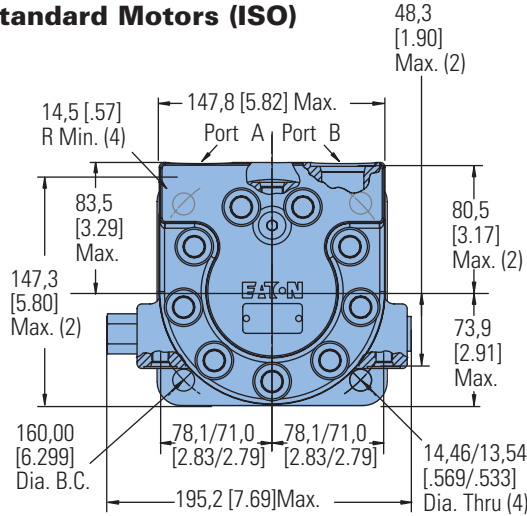

### STANDARD MOTORS (ISO)

Displacement cm <sup>3</sup> /r [in <sup>3</sup> /r]	X mm [inch]	Y mm [inch]	Z mm [inch]
325 [19.8]	247,4 [9.74]	219,5 [8.64]	174,2 [6.86]
400 [24.4]	253,7 [9.99]	225,8 [8.89]	180,8 [7.12]
505 [30.7]	263,1 [10.36]	235,0 [9.25]	189,7 [7.47]
570 [34.9]	269,2 [10.60]	241,0 [9.49]	196,1 [7.72]
630 [38.5]	274,3 [10.80]	246,4 [9.70]	201,4 [7.93]
685 [41.7]	278,9 [10.98]	251,0 [9.88]	205,7 [8.10]
785 [48.0]	288,0 [11.34]	260,1 [10.24]	215,1 [8.47]
940 [57.4]	301,8 [11.88]	273,8 [10.78]	228,9 [9.01]

### Wheel Motors (ISO)

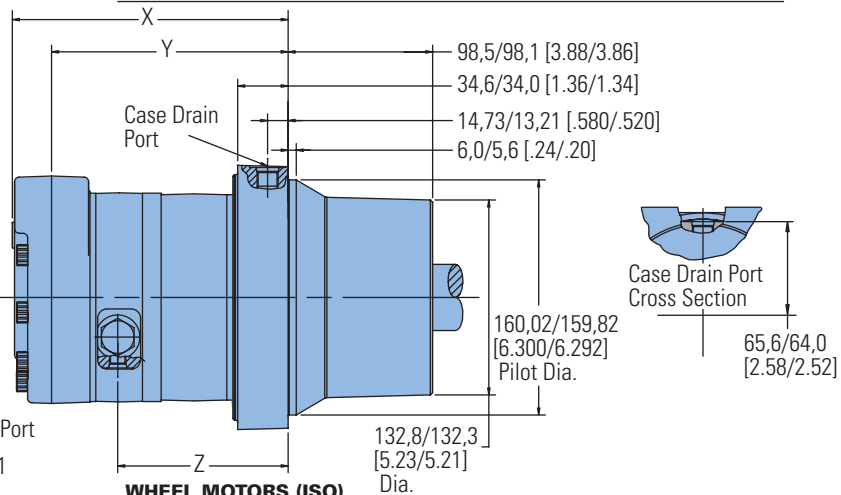
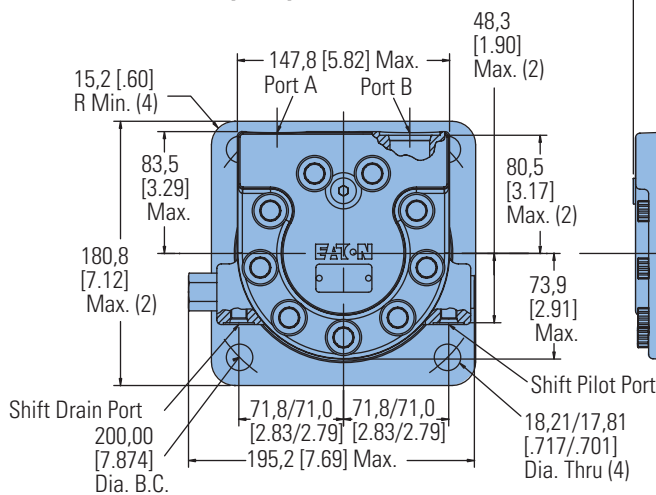

### WHEEL MOTORS (ISO)

Displacement cm <sup>3</sup> /r [in <sup>3</sup> /r]	X mm [inch]	Y mm [inch]	Z mm [inch]
325 [19.8]	173,2 [6.82]	145,3 [5.72]	100,1 [3.94]
400 [24.4]	179,6 [7.07]	151,6 [5.97]	106,7 [4.20]
505 [30.7]	189,0 [7.44]	160,8 [6.33]	115,6 [4.55]
570 [34.9]	195,1 [7.68]	166,9 [6.57]	121,9 [4.80]
630 [38.5]	200,2 [7.88]	172,2 [6.78]	127,3 [5.01]
685 [41.7]	204,7 [8.06]	176,8 [6.96]	131,6 [5.18]
785 [48.0]	213,9 [8.42]	185,9 [7.32]	141,0 [5.55]
940 [57.4]	227,6 [8.96]	199,6 [7.86]	154,7 [6.09]

# VIS 40 Series

## Two-speed

Dimensions

Bearingless

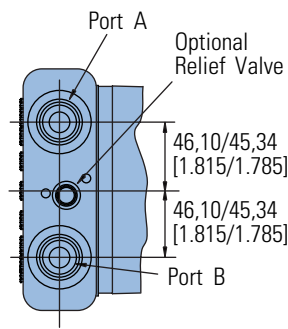

### Ports

- 1-1/16-12 UN-2B SAE O-ring Ports (2)
- 9/16-18 UNF-2B SAE O-ring Case Drain Port (1)
- 7/16 -20 UNF -2B SAE O-ring Shift Ports (2)
- or G 3/4 (BSP) O-ring Ports (2)
- G 1/4 (BSP) O-ring Case Drain Port (1)
- 7/16 -20 UNF -2B SAE O-ring Shift Ports (2)

### Standard Rotation Viewed from Drive End

Port A Pressurized — CW

Port B Pressurized — CCW

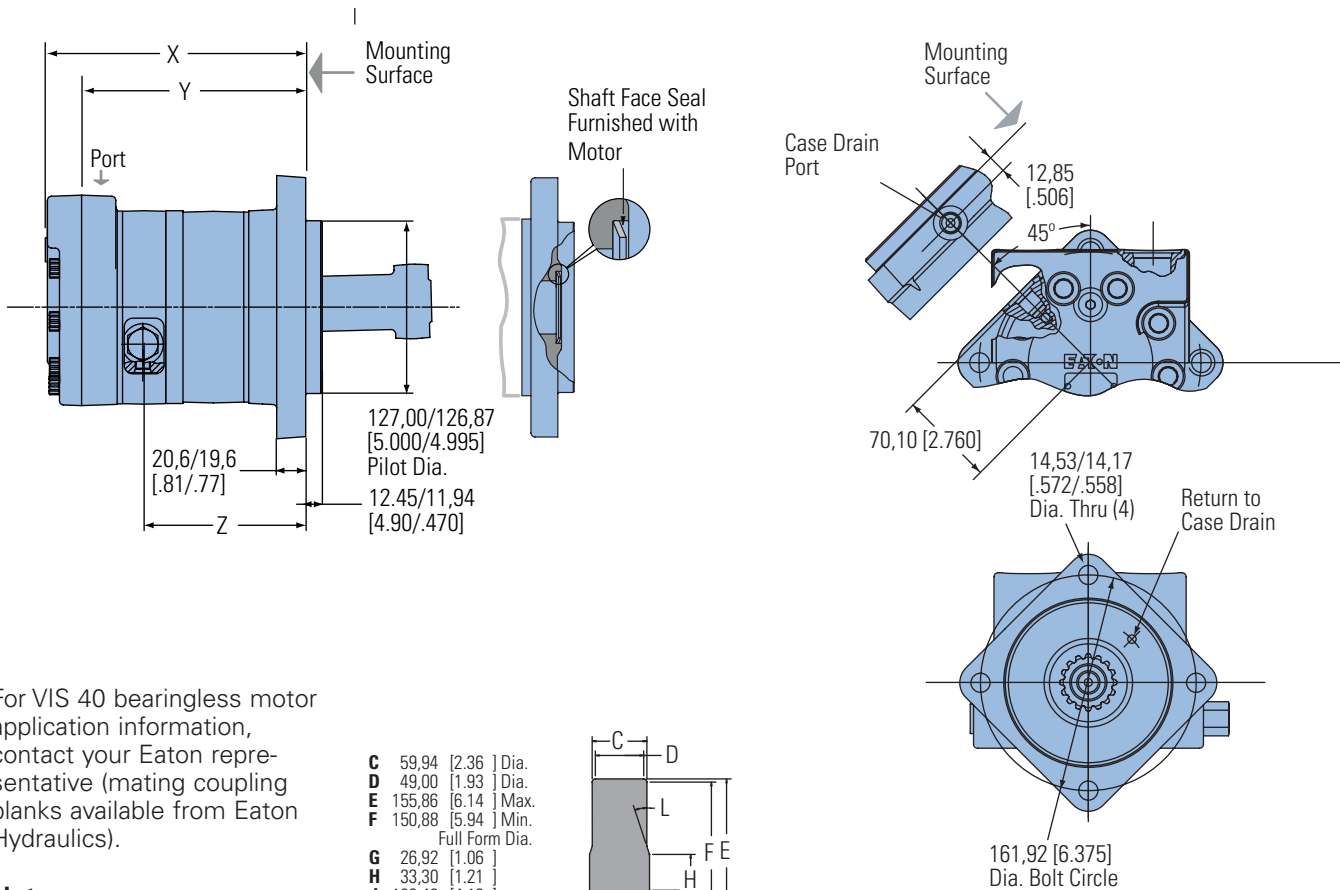

For VIS 40 bearingless motor application information, contact your Eaton representative (mating coupling blanks available from Eaton Hydraulics).

### Note:

After machining blank, part must be hardened per Eaton specification.

- C** 59,94 [2.36] Dia.
- D** 49,00 [1.93] Dia.
- E** 155,86 [6.14] Max.
- F** 150,88 [5.94] Min.
- G** 26,92 [1.06] Full Form Dia.
- H** 33,30 [1.21]
- J** 106,43 [4.19] Full Form Dia.
- K** 72,64 [2.86]
- L** 15

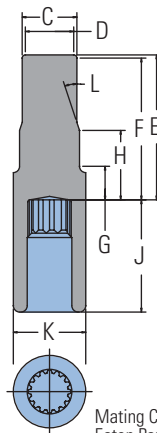

Mating Coupling Blank  
Eaton Part No. 13280-002

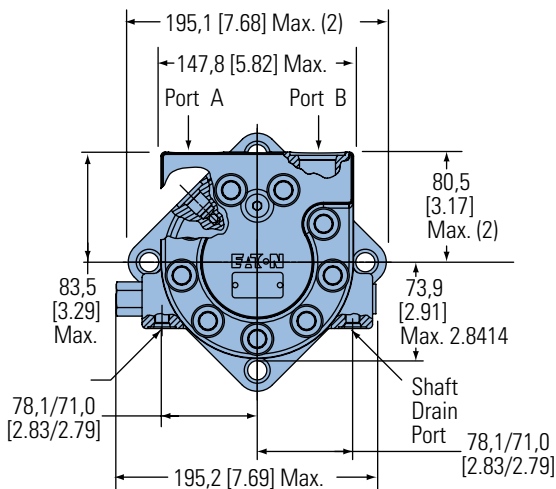

### BEARINGLESS MOTORS

Displacement cm <sup>3</sup> /r [in <sup>3</sup> /r]	X mm [inch]	Y mm [inch]	Z mm [inch]
325 [19.8]	177,0 [6.97]	149,1 [5.87]	103,9 [4.09]
400 [24.4]	183,6 [7.23]	155,7 [6.13]	110,7 [4.36]
505 [30.7]	193,0 [7.60]	164,8 [6.49]	119,6 [4.71]
570 [34.9]	199,1 [7.84]	170,9 [6.73]	126,0 [4.96]
630 [38.5]	204,0 [8.03]	176,0 [6.93]	131,1 [5.16]
685 [41.7]	208,8 [8.22]	180,8 [7.12]	135,6 [5.34]
785 [48.0]	217,9 [8.58]	190,0 [7.48]	145,0 [5.71]
940 [57.4]	231,6 [9.12]	203,7 [8.02]	158,8 [6.25]

# VIS 40 Series Two-speed

## Installation Information

### Bearingless

- 1 Internal spline in mating part to be per spline data. Specification material to be ASTM A304, 8620H carburize to a hardness of 60-64 HRC with case depth (to 50HRC) of 0,076 -1,27 [.030 -.050]. Dimensions apply after heat treat.
- ② Mating part to have critical dimensions as shown. Oil holes must be provided and open for proper oil circulation.
- ③ Seal to be furnished with motor for proper oil circulation thru splines.
- ④ Similar to SAE "C" Four Bolt Flange.

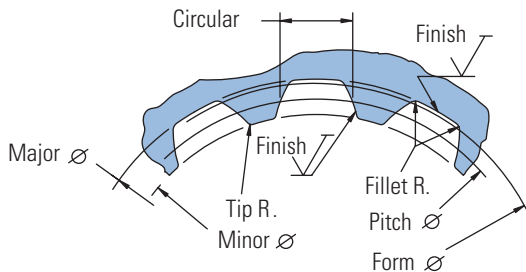
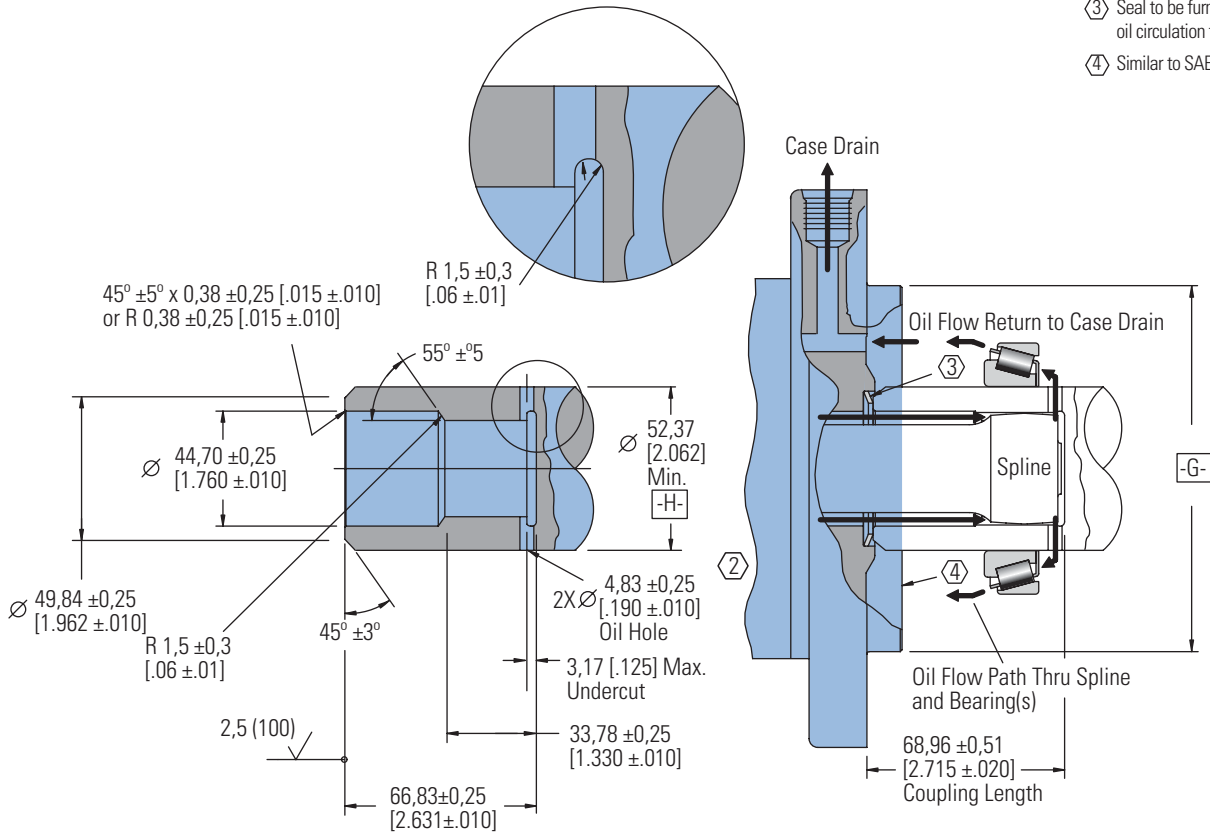

Spline Pitch.....	10/20
Pressure Angle.....	30°
Number of teeth.....	16
Class of Fit.....	Ref. 5
Type of Fit.....	Side
Pitch Diameter.....	Ref. 40,640000 [1.6000000] $\text{Ⓞ} 0,20$ [.008]   H
Base Diameter.....	Ref. 35,195272 [1.3856406]
Major Diameter.....	43,56 [1.715] Max. 43,18 [1.700]
Min. Minor Diameter.....	36,83 -37,08 [1.450 -1.460]
Form Diameter, Min.....	42.47 [1.672]
Fillet Radius.....	0,64 -0,76 [.025 -.030]
Tip Radius.....	0,25 -0,51 [.010 -.020]
Finish.....	1,6 (63)
Involute Profile Variation.....	+0,000 -0,025 [+ .0000 -.0010]
Total Index Variation.....	0,040 [.0016]
Lead Variation.....	0,013 [.0005]
Circular Space Width:	
Maximum Actual.....	4.105 [.1616]
Minimum Effective.....	3,995 [.1573]
Maximum Effective.....	Ref. 4,056 [.1597]
Minimum Actual.....	Ref. 4,081 [.1582]
Dimension Between Two Pins.....	Ref. 34,272 -34,450 [1.3493 -1.3563]
Pin Diameter.....	4,389 [.1728]

# VIS 40 Series Two-speed

Product Numbers

Closed Loop

Use digit prefix —  
176-, 178-, or 182- plus four  
digit number from charts for  
complete product number—  
Example 176-0022.

**Orders will not be accepted  
without three digit prefix.**

## SAE

MOUNTING	SHAFT	PORT SIZE	DISPL. cm <sup>3</sup> /r[in <sup>3</sup> /r] / PRODUCT NUMBER							
			325 [19.8]	400 [24.4]	505 [30.7]	570 [34.9]	630 [38.5]	685 [41.7]	785 [48.0]	940 [57.4]
Standard	40 mm Straight	1 1/16 -12 UNF O-ring (2) 9/16 -18 UNC Drain Port (1)	—	-0106	-0021	-0022	-0023	-0024	-0025	-0026
	1 1/2 inch 17 Tooth Splined	1 1/16 -12 UNF O-ring (2) 9/16 -18 UNC Drain Port (1)	178-0108	-0109	-0027	-0028	-0029	-0030	-0031	-0032
	1 3/4 inch Tapered	1 1/16 -12 UNF O-ring (2) 9/16 -18 UNC Drain Port (1)	—	-0128	-0033	-0034	-0035	-0036	-0037	-0038
Wheel	40 mm Straight	1 1/16 -12 UNF O-ring (2) 9/16 -18 UNC Drain Port (1)	—	—	-0002	-0003	-0004	-0005	-0006	-0007
	1 1/2 inch 17 Tooth Splined	1 1/16 -12 UNF O-ring (2) 9/16 -18 UNC Drain Port (1)	—	—	-0008	-0009	-0010	-0011	-0012	-0013
	1 3/4 inch Tapered	1 1/16 -12 UNF O-ring (2) 9/16 -18 UNC Drain Port (1)	—	182-0041	-0014	-0015	-0016	-0017	-0018	-0019
Bearingless		1 1/16 -12 UNF O-ring (2) 9/16 -18 UNC Drain Port (1)	176-0037	—	-0019	-0020	-0021	-0022	-0023	-0024

176-0022

## Oversize

MOUNTING	SHAFT	PORT SIZE	DISPL. cm <sup>3</sup> /r[in <sup>3</sup> /r] / PRODUCT NUMBER							
			325 [19.8]	400 [24.4]	505 [30.7]	570 [34.9]	630 [38.5]	685 [41.7]	785 [48.0]	940 [57.4]
Standard	40 mm Straight	1 1/16 -12 UNF O-ring (2) 9/16 -18 UNC Drain Port (1)	—	—	178-0039	-0040	—	—	—	—
	46 mm 28 Tooth Splined	1 1/16 -12 UNF O-ring (2) 9/16 -18 UNC Drain Port (1)	—	—	178-0045	-0046	—	—	—	—
	1 3/4 inch Tapered	1 1/16 -12 UNF O-ring (2) 9/16 -18 UNC Drain Port (1)	—	—	178-0051	-0052	—	—	—	—

## ISO

MOUNTING	SHAFT	PORT SIZE	DISPL. cm <sup>3</sup> /r[in <sup>3</sup> /r] / PRODUCT NUMBER							
			325 [19.8]	400 [24.4]	505 [30.7]	570 [34.9]	630 [38.5]	685 [41.7]	785 [48.0]	940 [57.4]
Standard	40 mm Straight	G 3/4 (BSP) (2) G 1/4 (BSP) Drain Port (1)	178-0110	-0111	-0057	-0058	-0059	-0060	-0061	-0062
	45 mm Tapered	G 3/4 (BSP) (2) G 1/4 (BSP) Drain Port (1)	178-0095	—	-0069	-0070	-0071	-0072	-0073	-0074
	1 1/2 inch 17 Tooth Splined	G 3/4 (BSP) (2) G 1/4 (BSP) Drain Port (1)	—	—	-0063	-0064	-0065	-0066	-0067	-0068
Wheel	40 mm Straight	G 3/4 (BSP) (2) G 1/4 (BSP) Drain Port (1)	182-0042	—	-0020	-0021	-0022	-0023	-0024	-0025
	45 mm Tapered	G 3/4 (BSP) (2) G 1/4 (BSP) Drain Port (1)	—	—	-0026	-0027	-0028	-0029	-0030	-0031
	1 1/2 inch 17 Tooth Splined	G 3/4 (BSP) (2) G 1/4 (BSP) Drain Port (1)	—	—	-0032	-0033	-0034	-0035	-0036	-0037
Bearingless		G 3/4 (BSP) (2) G 1/4 (BSP) Drain Port (1)	—	—	-0025	-0026	-0027	-0028	-0029	-0030

176-0028

### Note:

The product numbers on this page are for motors used in closed loop circuits. They include a back-pressure relief valve that is set at 4,5 bar [65 PSI].

- A case drain is required for all closed loop VIS motor applications.
- The maximum case pressure for the VIS motor is 3,5 bar [50 PSI].

# VIS 40 Series Two-speed

## Model Code

The following 16 - digit coding system has been developed to identify all of the configuration options for the VIS 40 two-speed motor. Use this model code to specify a motor with the desired features. All 16 digits of the code must be present when ordering. You may want to photocopy the matrix below to ensure that each number is entered in the correct box.

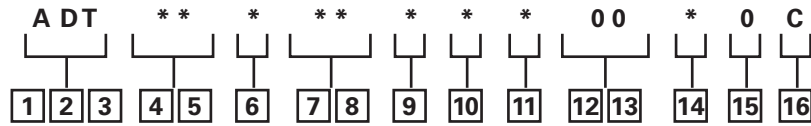

### 1, 2, 3 Product Series

**ADT** – VIS 40- Two-speed Motor

### 4, 5 Displacement – cm<sup>3</sup>/r [in<sup>3</sup>/r]

- 20** – 325 [19.8]
- 24** – 400 [24.4]
- 31** – 505 [30.7]
- 35** – 570 [34.9]
- 38** – 630 [38.5]
- 42** – 685 [41.7]
- 48** – 785 [48.0]
- 57** – 940 [57.4]

### 6 Mounting Type

**A** – 4 Bolt Bearingless 127,00 [5.000] Pilot Dia. with 12,19 [.480] Pilot Length and 14,35 [.565] Dia holes on 161,92 [6.375] Dia. Bolt Circle

**B** – 4 Bolt Wheel Mount 160,00 [6.3] Pilot Dia. With 5,8 [.23] Pilot Length and 18,00 [.709] Dia. Holes on 200,00 [7.874] Dia. Bolt Circle (ISO Compatible)

**C** – 4 Bolt Oversize Flange 185,4 [7.30] Rear Pilot Dia., 169,90 [6.689], 139,93 [5.509], 127,0 [5.00] Dia (Front Pilots) and 18,01 [.709] Dia. Holes on 224,00 [8.819] Dia. Bolt Circle

**F** – 4 Bolt Standard Mount (SAE CC) 127,00 [5.000] Pilot Dia. With 12,2 [.48] Pilot Length and 14,32 [.564] Dia. Holes on 161,92 [6.375] Dia.

Bolt Circle

**G** – 4 Bolt Wheel Mount 139,7 [5.50] Pilot Dia. with 7,9 [.31] Pilot Length and 14,32 [.564] Dia. Holes on 184,15 [7.250] Dia. Bolt Circle (SAE Compatible)

**H** – 4 Bolt Standard Mount 125,00 [4.92] Pilot Dia. With 8,9 [.35] Pilot Length and 14,00 [.551] Dia. Holes on 160,00 [6.299] Dia. Holes on 160,00 [6.299] Dia. Bolt Circle (ISO Compatible)

**M** – Standard, 4 Bolt: 169,75 [6.683] Pilot Dia. With 4.3 [.17] Pilot Length and M16 X 2 -6H Threaded Holes on 224,00 [8.819] Dia. Bolt Circle (To be selected for Brake Option)

### 7, 8 Output Shaft

**00** – None (Bearingless)

**01** – 45 mm Dia. 10:1 Tapered Shaft Per ISO R775 with M30X2-6H Threaded Shaft End, 12W X 8H X 28L [.472W X .313H X 1.102L] Key

**02** – 1-3/4 inch Dia. .125:1 Tapered Shaft Per SAE J501 with 1-1/4 - 18 UNEF-2A Threaded Shaft End, 11,11 [.4375] Square X 31,8 [1.25] Straight Key

**04** – 46 mm Dia. Flat Root Side Fit, 28 Tooth, 16/32 DP 30 Degree Involute Spline, 93,0 [3.66] Minimum Full Spline with M16 X 2,0-6H Thread in End

**07** – 40 mm Dia. Straight Shaft with M12 X 1,75-6H Thread in End, 12W X 8H X 63L [.472W X .313H X 2.480L] Key (SAE Compatible)

**08** – 1-1/2 inch Dia. Flat Root Side Fit, 17 Tooth, 12/24 DP 30 Degree Involute Spline, 39,1 [1.54] Minimum Full Spline with 3/8-16 UNC-2B Thread in End (SAE Compatible)

**09** – 1-1/2 inch Dia. Flat Root Side Fit, 17 Tooth, 12/24 DP 30 Degree Involute Spline, 56,6 [2.23] Minimum Full Spline with M12 X 1.75-6H Thread in End (ISO Compatible)

**10** – 40 mm Dia. Straight Shaft with M12 X 1,75-6H Thread in End, 12W X 8H X 67L [.472W X .313H X 2.630L] Key (ISO Compatible)

### 9 Ports

**A** – 1–1/16-12 UN-2B Size 12 O-ring Port, Accepts Fittings for SAE J1926

**B** – G 3/4 (BSP) Straight Thread Port

### 10 Case Flow Options

**A** – Shuttle Valve with 9/16-18 UNF-2B, Size 6 O-ring Port Case Drain, Accepts Fittings for SAE J1926

**B** – Shuttle Valve with G 1/4 (BSP) Straight Thread Port Case Drain

### 11 Back-Pressure Relief

**1** – Set at 4,5 bar [65 PSI] (for Manual Pumps)

**2** – Set at 15,2 bar [220 PSI] (for Servo Pumps)

**4** – Set at 15,2 bar [300 PSI] (for high charge Servo Pumps)

### 12, 13 Special Features

**00** – None

**08** – Spring Applied Hydraulic Release Wet Brake With Brake Capacity of 20,000 lbf-in Static and 150 lbf/in<sup>2</sup> release pressure

### 14 \_ Paint/ Special Packaging

**0** – Primer, Individual Box

**A** – Low Gloss Black Primer, Individual Box

**B** – No Paint, Bulk Box Option

**C** – Low Gloss Black Primer, Bulk Box Option

### 15 \_ Eaton Assigned Code when Applicable

**0** – Assigned Code

### 16 \_ Eaton Assigned Design Code

**C** – Assigned Design Code

# VIS 40 Series

## Brake Description

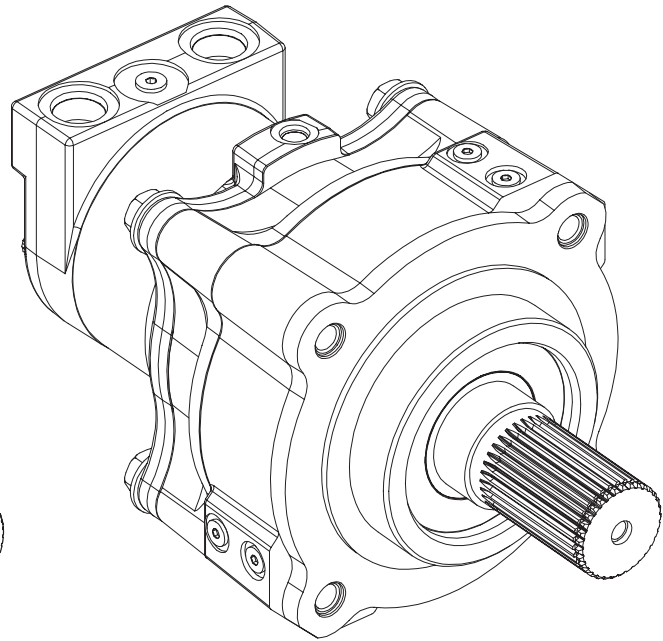
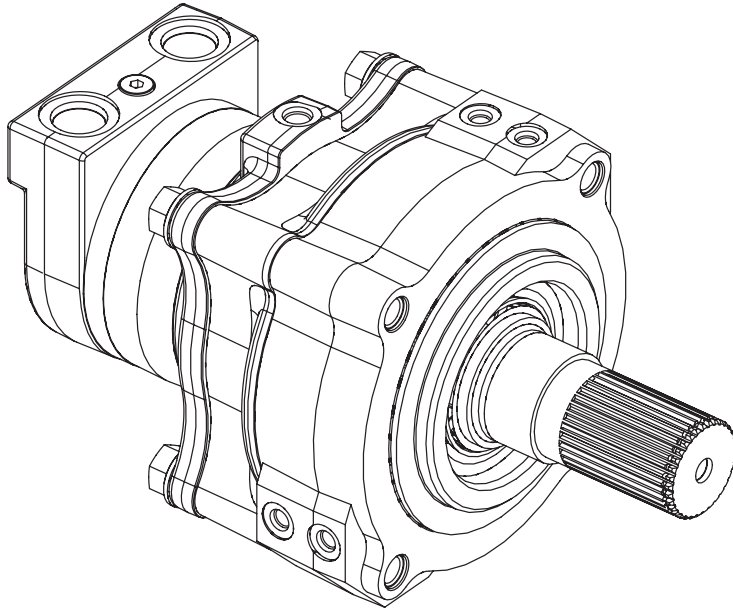

Brake Motor WITH Outer Grease Seal

### Features

- Spring-Applied/ Hydraulically Released Multi-Disc Brake
- Spring automatically applies brake when hydrostatic pressure is absent
- Environmentally Protected
- Integral Design – Motor and brake as a single package to minimize length and cost.
- Infinite Braking – Eliminates machine creep associated with park pawl mechanisms
- Boost Feature – Increases holding capacity to match full motor output torque
- No adjustments needed
- Two Sets of Release and Boost Ports – Allows for multiple plumbing options and facilitates bleeding
- Outer Grease Seal - optional feature that encloses the front bearing protecting it from external contamination

### Applications

- Skid Steer Loaders
- Mini Excavators
- Trenchers
- Road Rollers
- Anywhere load-holding is needed on a Low-Speed High-Torque drive system

### Specifications

- Static Holding Torque – 780 N-m [6900 lb-in] minimum (spring only - no boost)  
2621 N-m [23200 lb-in] minimum (@ 10,3 bar [150 PSI] boost)  
3570 N-m [31600 lb-in] minimum (@ 15,2 bar [220 PSI] boost)
- Release Pressure – 10,3 bar [150 PSI] minimum for full release  
68,9 bar [1000 PSI] maximum allowed at release port
- Case Pressure – 1,4 bar [20 PSI] continuous  
3,5 bar [50 PSI] maximum
- Boost Pressure – 15,2 bar [220 PSI] continuous  
34,5 bar [500 PSI] maximum
- Speed – 360 RPM maximum
- Emergency – After 3 consecutive stops, brake to still meet parking requirement

### Model Code Selection:

To add a brake to the motor, select Mounting Option 'M' from Mounting Options and select Brake Option from Special Features.

# VIS 40 Series

## Brake Dimensions

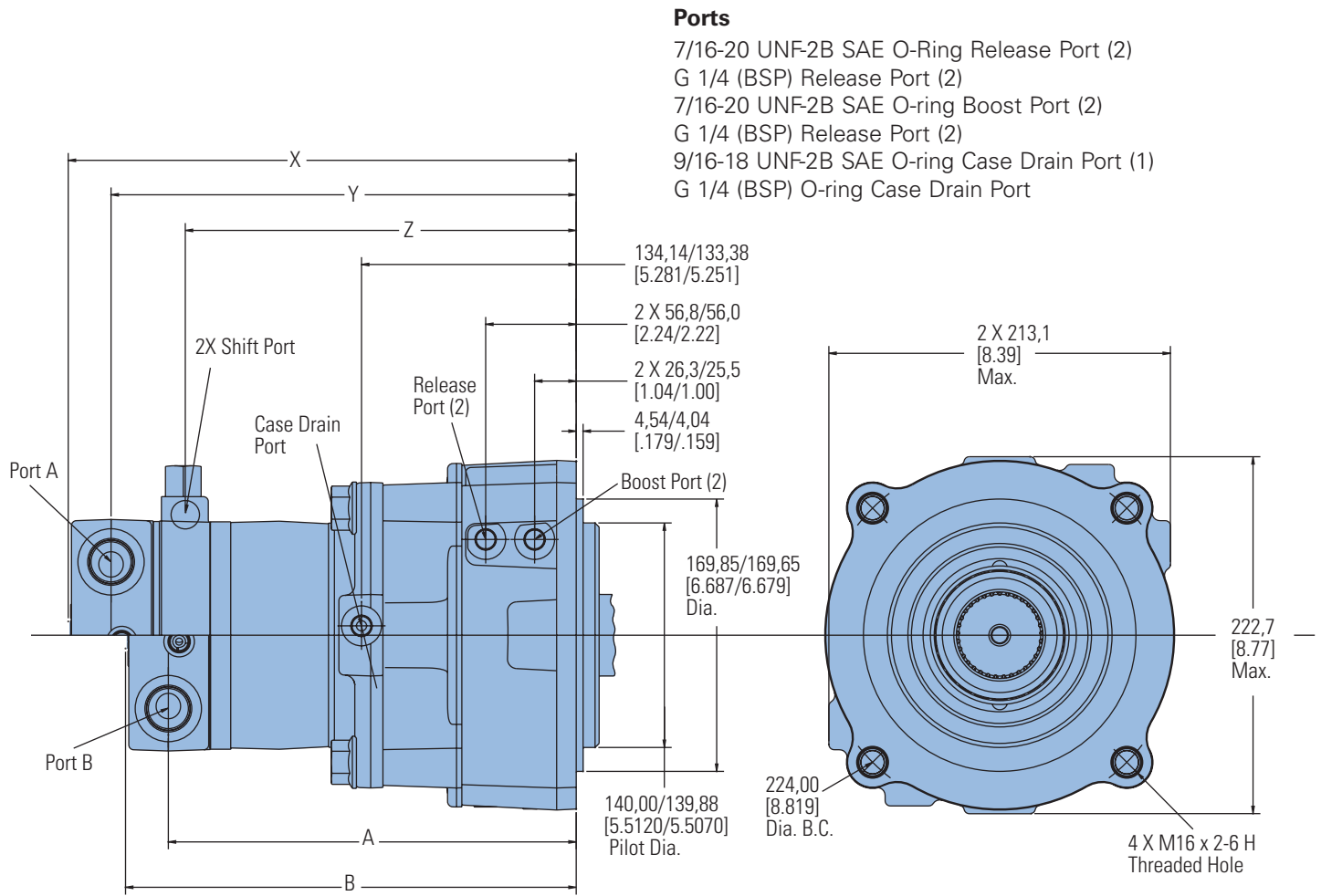

### BRAKE MOTORS (SINGLE-SPEED)

Displacement cm <sup>3</sup> /r [in <sup>3</sup> /r]	A mm [inch]	B mm [inch]
325 [19.8]	220,9 [8.78]	250,2 [9.85]
400 [24.4]	229,7 [9.05]	256,9 [10.11]
505 [30.7]	238,7 [9.40]	265,9 [10.47]
570 [34.9]	244,9 [9.64]	272,1 [10.71]
630 [38.5]	250,1 [9.85]	277,3 [10.92]
685 [41.7]	254,7 [10.04]	281,9 [11.10]
785 [48.0]	264,0 [10.40]	291,2 [11.46]
940 [57.4]	277,7 [10.94]	304,9 [12.00]

### BRAKE MOTORS (TWO-SPEED)

Displacement cm <sup>3</sup> /r [in <sup>3</sup> /r]	X mm [inch]	Y mm [inch]	Z mm [inch]
325 [19.8]	286,1 [11.26]	258,9 [10.20]	213,5 [8.41]
400 [24.4]	292,7 [11.52]	265,7 [10.46]	220,3 [8.67]
505 [30.7]	301,9 [11.88]	274,7 [10.82]	229,3 [9.03]
570 [34.9]	308,0 [12.12]	280,9 [11.06]	235,5 [9.27]
630 [38.5]	313,1 [12.32]	285,9 [11.27]	238,5 [9.27]
685 [41.7]	317,9 [12.52]	290,7 [11.45]	245,3 [9.66]
785 [48.0]	327,0 [12.88]	300,0 [11.80]	254,6 [10.02]
940 [57.4]	340,7 [13.42]	313,7 [12.35]	268,3 [10.56]

# VIS 40 Series

## Brake Shaft Dimensions/ Sideload Curves

### Standard Brake

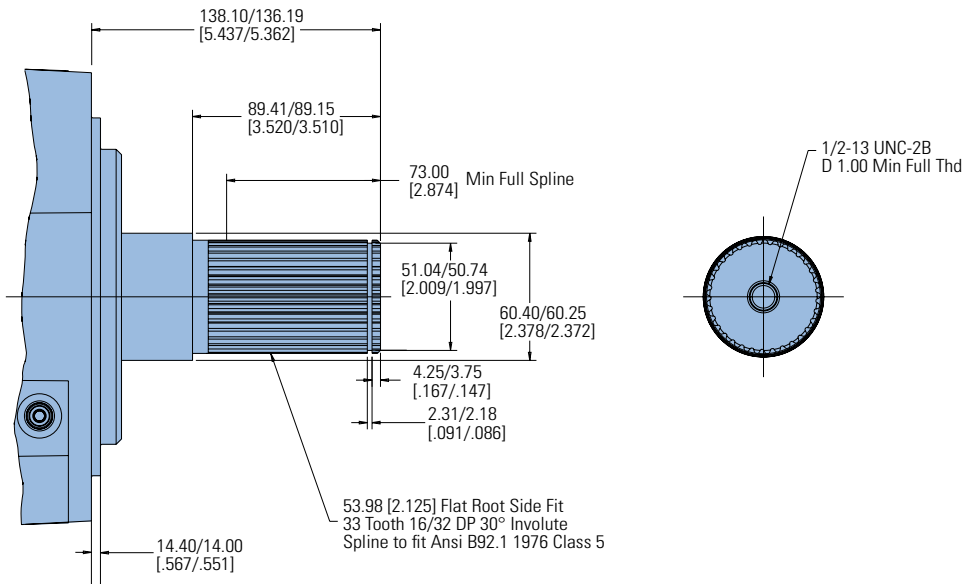

### Brake with Outer Grease Seal

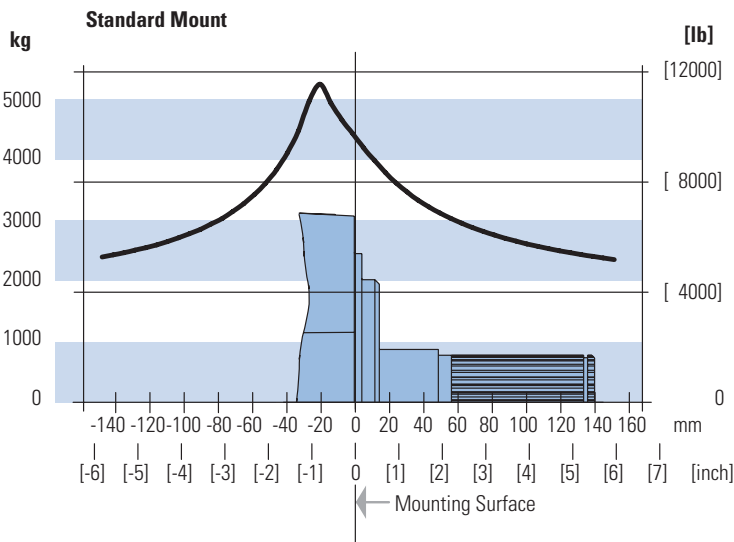
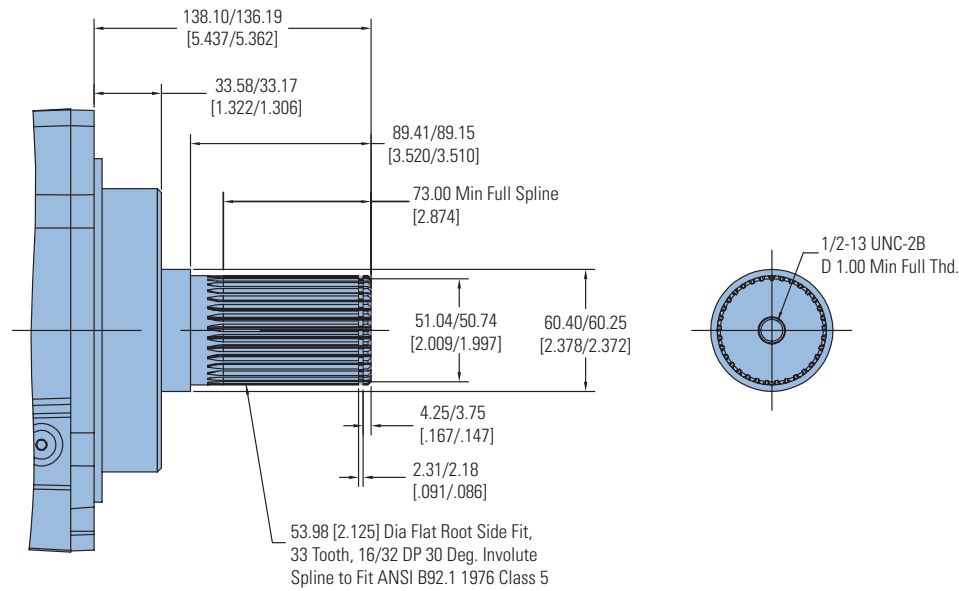



# VIS 45 Series

## Highlights

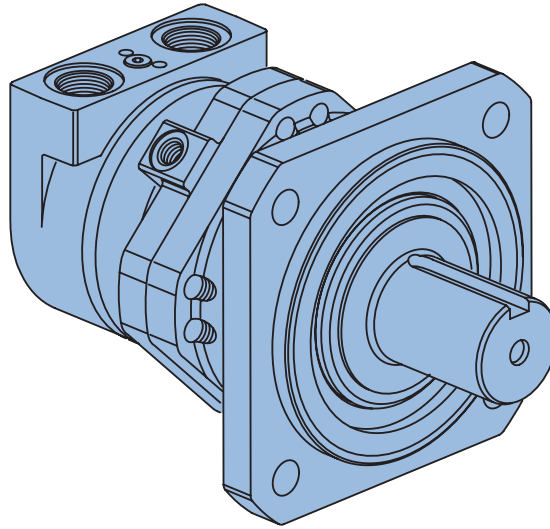

### Description

The VIS 45 is the most powerful motor in the VIS Series product line. Maximum continuous output torque capability is rated to 4520 Nm [40,000 lb-in.] with a displacement range from 630cc to 1560cc per revolution. VIS 45 motors can be run up to 170 LPM [45 GPM] with pressure capability up to 310 bar [4500 PSI]. The motor utilizes patented VIS technology with improved high-strength Geroler, optimized drive geometry, and two-piece pre-loaded balance plate for increased starting efficiency, reduced leakage and higher back pressure capacity.

### VIS 45 Motors

Geroler Element	5 Displacements
Flow l/min [GPM]	170 [45] Continuous 189 [50] Intermittent
Speed	Up to 284 RPM
Pressure bar [PSI]	310 [4500] Cont. 345 [5000] Inter. 380 [5500] Peak
Torque Nm [lb - in]	4520 [40000] Cont. 5650 [50000] Inter.

### Features

- Patented VIS Geroler technology
- Three moving components: (Geroler, star, drive, and output shaft)
- Two-piece pre-loaded pressure balance plate
- Variety of optional features including two-speed option, and case flow solutions for both closed-loop and open-loop applications.

### Benefits

- Extremely compact powerful package
- Increased torque capability
- Greatest horsepower density in the VIS motor line
- High efficiency
- Quiet, smooth operation
- Reliable performance
- Design Flexibility

### Applications

- Traction Drives
- Skid Steer loaders
- Grapples
- Excavator Swing Drives
- Marine & Military Winches
- Utility Reels
- Harvesters
- Snow Grooming Equipment
- Trenchers
- Piggy-back Forklifts
- Industrial Machine Tools
- Truck Grapples
- Wood Processing – Saw Mills
- Augers



Auger



Skid Steer



Injector



Port Equipment

# VIS 45 Series

## Specifications

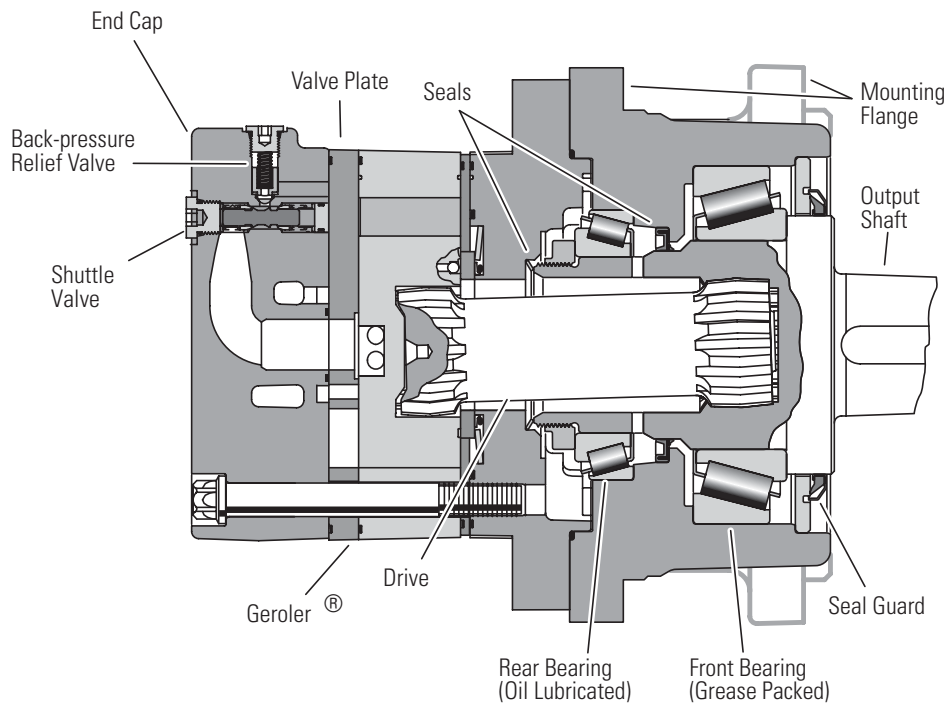

### SPECIFICATION DATA – VIS 45 SERIES MOTORS

Displ. cm <sup>3</sup> /r [in <sup>3</sup> /r]		630 [38.6]	805 [48.6]	990 [60.5]	1245 [76.0]	1560 [95.0]
Max. Speed (RPM)	Continuous	256	198	164	129	104
	Intermittent	284	220	183	143	115
@ Flow						
Flow l/min [GPM]	Continuous	170 [45]	170 [45]	170 [45]	170 [45]	170 [45]
	Intermittent	189 [50]	189 [50]	189 [50]	189 [50]	189 [50]
Torque Nm [lb-in]	Continuous	2963 [26080]	3555 [31460]	4052 [35860]	4520 [40000]	4520 [40000]
	Intermittent	3111 [27530]	3722 [32940]	4549 [40269]	5376 [47592]	5650 [50000]
Pressure $\Delta$ bar [ $\Delta$ PSI]	Continuous	310 [4500]	310 [4500]	258 [3740]	205 [2975]	164 [2380]
	Intermittent	345 [5000]	345 [5000]	322 [4675]	256 [3720]	205 [2975]
	Peak	379 [5500]	379 [5500]	379 [5500]	308 [4465]	246 [3570]
Weight kg [lb]	Standard or Wheel Mount Bearingless	53,8 [118.7]	55,2 [121.6]	56,7 [125.0]	58,7 [129.4]	61,2 [134.9]
	Two-speed Standard or Wheel Mount Two-speed Bearingless	28,3 [62.3]	29,6 [65.2]	31,1 [68.6]	33,1 [73.0]	35,6 [78.5]
Weight kg [lb]	Two-speed Standard or Wheel Mount	58,5 [128.9]	59,8 [131.8]	61,3 [135.2]	63,3 [139.6]	65,8 [145.1]
	Two-speed Bearingless	32,9 [72.5]	34,2 [75.4]	35,7 [78.8]	37,7 [83.2]	40,2 [88.7]

A simultaneous maximum torque and maximum speed NOT recommended.

#### Note:

To assure best motor life, run motor for approximately one hour at 30% of rated pressure before application to full load. Be sure motor is filled with fluid prior to any load applications.

#### Maximum Inlet Pressure:

400 bar [5800 PSI]  
Do Not Exceed A Pressure Rating (for displacement size see chart above).

#### Return Pressure (Back-Pressure):

Minimum – 3,5 bar [50 PSI]  
Maximum – 21 bar [300 PSI]

#### Note:

Return (back-pressure) must be 3,5 bar [50 PSI] greater than the case pressure, except with open loop circuit.

#### $\Delta$ Pressure:

The true  $\Delta$  bar [ $\Delta$  PSI] between inlet port and outlet port

#### Case Pressure:

Minimum – No Pressure  
Maximum – 3,5 bar [50 PSI]

#### Note:

The case must be full when the motor is operating. A case drain is recommended.

#### Continuous Rating:

Motor may be run continuously at these ratings

#### Intermittent Operation:

10% of every minute

#### Peak Operation:

1% of every minute

#### Recommended Fluids:

Premium quality, anti-wear type hydraulic oil with a viscosity of not less than 70 SUS at operating temperature.

#### Recommended System Operating Temp.:

-34°C to 82°C [-30°F to 180°F]

#### Recommended Filtration:

Per ISO Cleanliness Code, 4406: 20/18/13

#### Shuttle:

Standard

#### Back-Pressure Relief Valve:

Required for closed loop circuit.

# VIS 45 Series

## Performance Data

Motors run with high efficiency in all areas designated with a number for torque and speed. For best motor life select a motor to run with a torque and speed range shown in the light shaded area.

Performance data is typical at 120 SUS. Actual data may vary slightly from unit to unit in production.

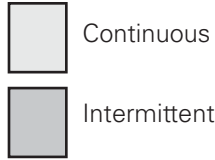

### 805 cm³/r [48.6 in³/r]

□ Pressure Bar [PSI]

	250 15	500 35	1000 70	1500 105	2000 140	2500 170	3000 205	3500 240	4000 275	4500 310	5000 345
4	1600	3350	7180	10670	13480	16640	19680	21740	25860	28500	31720
15	181	379	811	1206	1523	1880	2224	2457	2922	3221	3584
8	1620	3380	7240	10730	13740	16920	19950	22160	25920	28970	32200
15	183	382	818	1212	1553	1912	2254	2504	2929	3274	3639
30	38	36	35	34	34	34	34	34	32	31	29
12	1640	3310	7180	10770	14170	17290	20730	23270	26340	29420	32470
15	185	374	811	1217	1601	1954	2342	2630	2976	3324	3669
45	56	55	52	52	51	51	50	50	49	47	45
16	1660	3220	7010	10680	14290	17710	21240	24170	26830	30340	32940
15	188	364	792	1207	1615	2001	2400	2731	3032	3428	3722
61	76	74	71	70	69	69	68	68	67	64	60
20	1600	3110	6840	10380	14000	17290	20990	24490	27270	31390	
15	181	351	773	1173	1582	1954	2372	2767	3082	3547	
76	95	92	88	87	86	86	85	85	84	80	
24	1560	3030	6750	10250	13830	17340	21110	24450	27620	31460	
15	176	342	763	1158	1563	1959	2385	2763	3121	3555	
91	114	110	105	104	103	103	102	102	101	96	
28		2720	6560	10190	13780	17390	21090	24360	27420	31238	
106		307	741	1151	1557	1965	2383	2753	3098	3529	
121		128	123	121	120	120	119	119	117	111	
32		2620	6330	10000	13480	17070	20730	24180	27270	31064	
121		296	715	1130	1523	1929	2342	2732	3082	3509	
36		147	140	139	137	137	135	135	134	127	
136		2620	5910	9480	13140	16640	20200	23570	26910	30646	
136		296	668	1071	1485	1880	2283	2663	3041	3462	
40		165	158	156	154	154	152	152	150	143	
151			5390	9220	12790	16120	19700	23080	26343	30019	
151			609	1042	1445	1822	2226	2608	2976	3391	
45			175	173	171	171	169	169	167	159	
170			5150	8970	12450	15780	19420	22650	25848	29462	
170			582	1014	1407	1783	2194	2559	2920	3328	
50			198	196	193	193	191	191	189	179	
189			4770	8610	12140	15380	19180	22440			
189			539	973	1372	1738	2167	2536			
			220	217	215	215	212	212			

### 630 cm³/r [38.6 in³/r]

□ Pressure Bar [PSI]

	250 15	500 35	1000 70	1500 105	2000 140	2500 170	3000 205	3500 240	4000 275	4500 310	5000 345
4	1270	2710	5530	8250	10300	12900	15540	17720	20820	23640	25740
15	144	306	625	932	1164	1458	1756	2002	2353	2671	2909
8	1290	2720	5580	8290	10490	13110	15760	18070	21000	24100	26070
15	146	307	631	937	1185	1481	1781	2042	2373	2723	2946
30	47	45	45	45	45	44	43	41	38	36	34
12	1310	2670	5440	8320	10820	13400	16370	18970	21230	24540	26840
15	148	302	615	940	1223	1514	1850	2144	2399	2773	3033
45	71	68	68	67	67	66	64	62	61	58	54
16	1320	2600	5400	8250	10910	13730	16780	19710	21970	24870	27530
15	149	294	610	932	1233	1551	1896	2227	2483	2810	3111
61	95	91	91	89	89	88	85	83	81	77	72
20	1290	2500	5270	8020	10690	13400	16730	20020	22320	25420	
76	146	283	596	906	1208	1514	1890	2262	2522	2872	
91	119	114	114	113	113	111	108	104	103	97	
24	1240	2440	5200	7920	10560	13430	16700	19970	22610	25730	
140	276	588	895	1193	1518	1887	2257	2555	2907		
91	143	137	137	135	135	133	129	125	123	117	
28		2190	5050	7870	10520	13480	16660	19860	22450	26080	
106		247	571	889	1189	1523	1883	2244	2537	2963	
121		160	160	157	157	155	150	146	143	136	
32		2110	4870	7720	10300	13230	16370	19720	22320	25986	
121		238	550	872	1164	1495	1850	2228	2522	2936	
36		182	182	180	180	177	172	166	164	156	
136		2090	4550	7330	10030	12890	15960	19220	22040	25655	
136		236	514	828	1133	1457	1803	2172	2491	2898	
40		205	205	202	202	199	193	187	184	175	
151			4150	7120	9760	12490	15560	18820	21600	25185	
45			469	805	1103	1411	1758	2127	2441	2845	
170			228	224	224	221	214	208	204	194	
50			3970	6930	9500	12230	15340	18470	21207	24742	
189			449	783	1074	1382	1733	2087	2396	2795	
189			256	252	252	249	241	234	229	218	
			3680	6660	9270	11920	15150	18300			
			416	753	1048	1347	1712	2068			
			284	280	280	276	268	259			



# VIS 45 Series

## Performance Data

Motors run with high efficiency in all areas designated with a number for torque and speed. For best motor life select a motor to run with a torque and speed range shown in the light shaded area.

Performance data is typical at 120 SUS. Actual data may vary slightly from unit to unit in production.

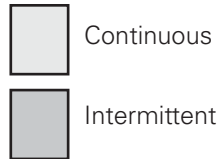

**1245 cm<sup>3</sup>/r [76.0 in<sup>3</sup>/r]**  
□ Pressure Bar [PSI]

	250	500	1000	1500	2000	2500	3000	3500	4000	4250
	15	35	70	105	140	170	205	240	275	295
4	2160	4800	9960	15150	20200	26450	30670	39180	42800	43220
15	244	542	1125	1712	2283	2989	3466	4427	4836	4884
8	2250	4830	10370	15760	22010	27180	33330	39840	43660	44400
30	254	546	1172	1781	2487	3071	3766	4502	4934	5017
12	2400	5390	10910	17290	22780	28470	34170	40140	44160	47220
45	271	609	1233	1954	2574	3217	3861	4536	4990	5336
16	2410	5150	10930	16970	22880	28600	33900	39500	44510	47592
61	272	582	1235	1918	2585	3232	3831	4464	5030	5376
20	2350	4890	10650	16470	21960	27450	33130	37710	43890	46933
76	266	553	1203	1861	2481	3102	3744	4261	4960	5302
24	2190	4760	10460	15920	21230	26530	32320	37680	42670	45673
91	247	538	1182	1799	2399	2998	3652	4258	4822	5156
28	1990	4260	10070	15860	21200	26420	32480	37500	42464	45418
106	225	481	1138	1792	2396	2985	3670	4238	4797	5131
32		4100	9770	15410	20770	26300	31920	37240	42167	45103
121		463	1104	1741	2347	2972	3607	4208	4764	5095
36		4090	9060	14650	20060	25670	31110	36295	41087	43955
136		462	1024	1655	2267	2901	3515	4100	4642	4966
40			8300	14150	19570	24900	30320	35373	40034	42836
151			938	1599	2211	2814	3426	3996	4523	4839
45			8100	13970	19310	24610	29972	34967	39570	42343
170			915	1579	2182	2781	3386	3950	4470	4783
50			7900	13790	19050	24310				
189			893	1558	2153	2747				

**990 cm<sup>3</sup>/r [60.5 in<sup>3</sup>/r]**  
□ Pressure Bar [PSI]

	250	500	1000	1500	2000	2500	3000	3500	4000	4500	4750
	15	35	70	105	140	170	205	240	275	310	330
4	2000	4100	8630	12620	16050	20080	24150	28320	32590	35150	37040
15	226	463	975	1426	1814	2269	2729	3200	3683	3972	4186
8	2020	4130	8700	12740	16350	20420	24480	28400	32850	35670	37250
30	228	467	983	1440	1848	2307	2766	3209	3712	4031	4209
12	2050	4050	8630	12780	16870	20860	25440	28550	32920	35860	37630
45	232	458	975	1444	1906	2357	2875	3226	3720	4052	4252
16	2070	3940	8420	12680	17010	21380	26070	29660	33020	36620	38439
61	234	445	951	1433	1922	2416	2946	3352	3731	4138	4342
20	2000	3800	8220	12330	16660	20860	25760	30060	33550	37880	39766
76	226	429	929	1393	1883	2357	2911	3397	3791	4280	4492
24	1950	3700	8120	12180	16460	20890	25820	30090	33990	38366	40269
91	220	418	918	1376	1860	2361	2918	3400	3841	4334	4549
28		3320	7880	12100	16400	20990	25890	29900	33750	39106	39995
106		375	890	1367	1853	2372	2926	3379	3814	4280	4518
32		105	102	102	101	99	97	97	95	92	90
121		3210	7610	11870	16050	20600	25440	29680	33550	37890	39766
36		363	860	1341	1814	2328	2875	3354	3791	4280	4492
136		120	117	117	115	114	110	110	109	106	103
40		3200	7100	11260	15640	20080	24800	28930	32716	36936	38759
151		362	802	1272	1767	2269	2802	3269	3696	4173	4379
45		135	131	131	130	128	124	124	123	119	116
170			6480	10950	15220	19460	24170	28330	32023	36155	37935
50			732	1237	1720	2199	2731	3201	3618	4084	4286
189			146	146	144	142	138	138	137	133	130
			6190	10650	14810	19040	23830	27952	31599	35679	37432
			699	1203	1674	2152	2693	3158	3570	4031	4229
			164	164	162	160	155	155	154	149	145
			5740	10230	14450	18570	23540				
			649	1156	1633	2098	2660				
			183	183	180	178	173				

[18570] Torque [lb-in]  
2098 } Nm  
178 Speed RPM

# VIS 45 Series

1560 cm<sup>3</sup>/r [95.0 in<sup>3</sup>/r]

## Performance Data

Motors run with high efficiency in all areas designated with a number for torque and speed. For best motor life select a motor to run with a torque and speed range shown in the light shaded area.

Performance data is typical at 120 SUS. Actual data may vary slightly from unit to unit in production.

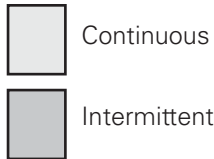

□ Pressure Bar [PSI]

Flow LPM [GPM]	250	500	1000	1500	2000	2500	3000	3500	4000
	15	35	70	105	140	170	205	240	275
4	2700	5670	11910	18520	24910	30860	37610	42320	48366
15	305	641	1346	2093	2815	3487	4250	4782	5464
8	2810	5910	12400	19260	25590	31740	39310	44150	50457
30	318	668	1401	2176	2892	3587	4442	4989	5700
12	3010	6300	13040	20490	26600	33070	39880	46670	53337
45	340	712	1474	2315	3006	3737	4506	5274	6025
16	3020	6300	13360	20740	27270	33950	40450	48630	55577
61	341	712	1510	2344	3082	3836	4571	5495	6279
20	2930	6150	13200	20490	27110	34830	39820	47662	54470
76	331	695	1492	2315	3063	3936	4500	5384	6154
24	2780	5910	12880	19750	26930	34390	39310	47300	54057
91	314	668	1455	2232	3043	3886	4442	5343	6107
28	58	56	55	54	53	50	47	44	44
106		5310	12500	19630	26600	33950	38740	46635	53297
		600	1413	2218	3006	3836	4378	5268	6021
		66	64	63	62	59	55	52	52
32		5120	12070	19260	26260	33510	38180	45982	52550
121		579	1364	2176	2967	3787	4314	5195	5937
		75	74	72	70	67	62	58	58
36		5100	11270	18270	25590	33070	37652	45366	
136		576	1274	2065	2892	3737	4254	5125	
		85	83	81	79	76	70	66	
40			10280	17760	24910	32630	37124	44750	
151			1162	2007	2815	3687	4194	5055	
			92	90	88	84	78	73	
45			9820	17280	24240	31793	36119	43577	
170			1110	1953	2739	3592	4080	4923	
			104	101	99	95	87	82	
50			9100	16600	23650				
189			1028	1876	2672				
			115	113	110				

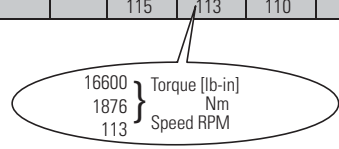

# VIS 45 Series

## Dimensions

### Standard Mount

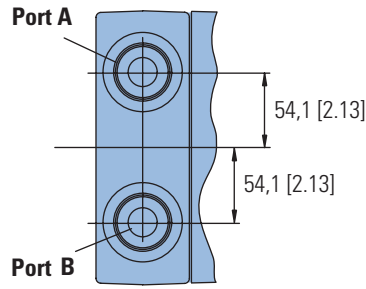

## Ports

- 1-5/16-12 UN-2B SAE O-ring Ports (2)
- 9/16-18 UNF-2B SAE O-ring Case Drain Port (1)
- Or G 1 (BSP) O-ring Ports (2)
- G 1/4 (BSP) O-ring Case Drain Port (1)

## Standard Rotation Viewed from Shaft End

- Port A Pressurized — CW
- Port B Pressurized — CCW

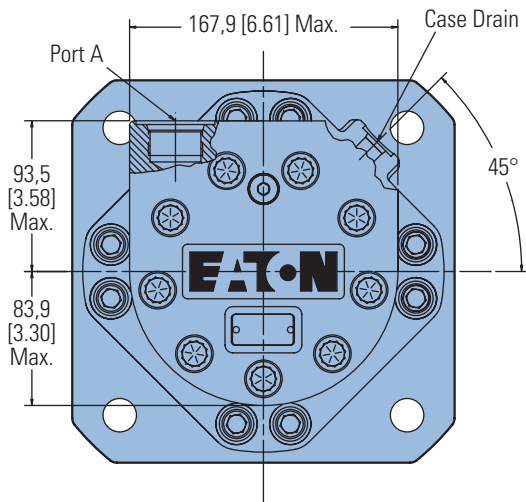
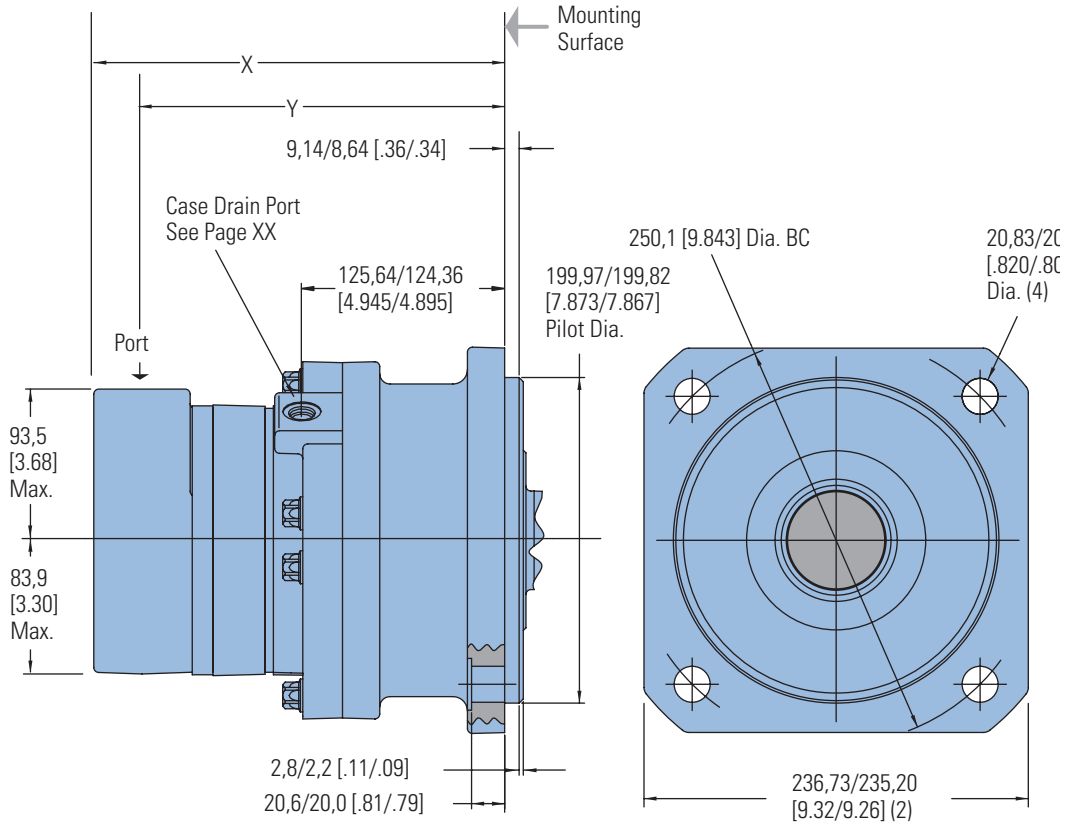

## STANDARD MOTORS

Displacement cm <sup>3</sup> /r [in <sup>3</sup> /r]	X Max. mm [inch]	Y mm [inch]
630 [38.6]	260,9 [10.27]	228,6 [ 9.00]
805 [48.6]	271,3 [10.68]	239,0 [ 9.41]
990 [60.5]	283,7 [11.17]	251,5 [ 9.90]
1245 [76.0]	299,7 [11.80]	267,7 [10.54]
1560 [95.0]	319,5 [12.58]	287,5 [11.32]

# VIS 45 Series

Dimensions

Wheel Mount

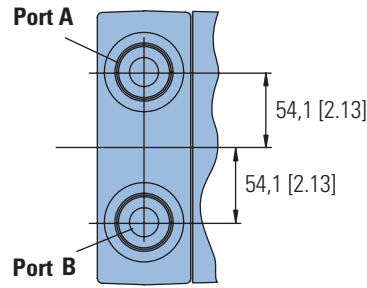

## Ports

- 1-5/16-12 UN-2B SAE O-ring Ports (2)
- 9/16-18 UNF-2B SAE O-ring Case Drain Port (1)
- Or G 1 (BSP) O-ring Ports (2)
- G 1/4 (BSP) O-ring Case Drain Port (1)

## Standard Rotation Viewed from Shaft End

- Port A Pressurized — CW
- Port B Pressurized — CCW

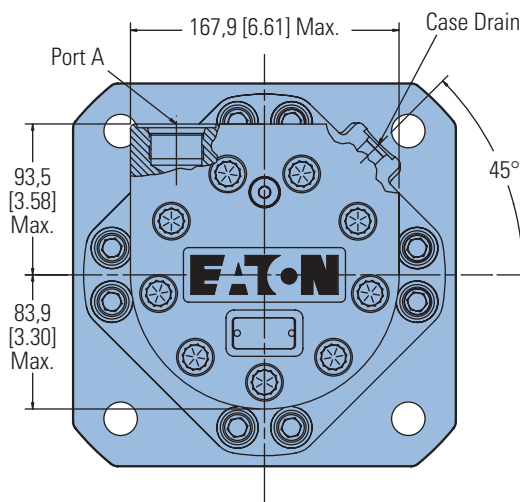
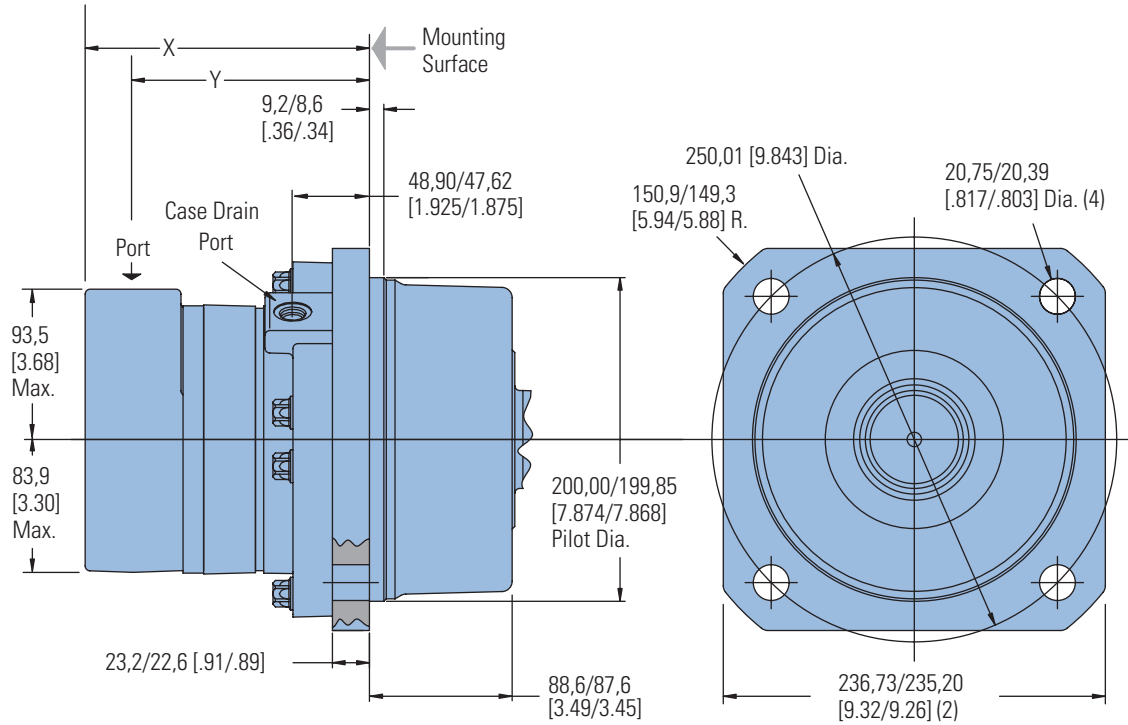

## WHEEL MOTORS

Displacement cm <sup>3</sup> /r [in <sup>3</sup> /r]	X Max. mm [inch]	Y mm [inch]
630 [38.6]	184,2 [7.25]	151,9 [5.98]
805 [48.6]	194,6 [7.66]	162,3 [6.39]
990 [60.5]	207,0 [8.15]	174,8 [6.88]
1245 [76.0]	223,0 [8.78]	191,0 [7.52]
1560 [95.0]	242,8 [9.56]	210,8 [8.30]

# VIS 45 Series

Dimensions  
Bearingless

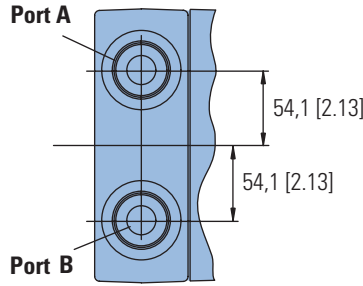

## Ports

- 1-5/16-12 UN-2B SAE O-ring Ports (2)
- 9/16-18 UNF-2B SAE O-ring Case Drain Port (1)
- Or G 1 (BSP) O-ring Ports (2)
- G 1/4 (BSP) O-ring Case Drain Port (1)

## Standard Rotation Viewed from Drive End

- Port A Pressurized — CW
- Port B Pressurized — CCW

For VIS 45 bearingless motor application information, contact your Eaton representative (mating coupling blanks available from Eaton Hydraulics).

### Note:

After machining blank, part must be hardened per Eaton specification.

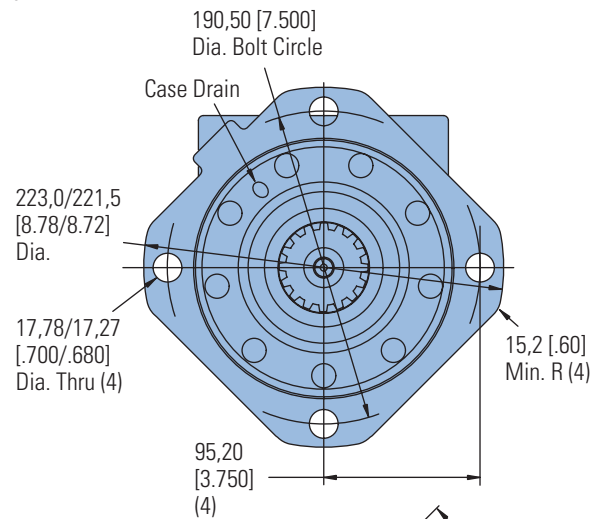
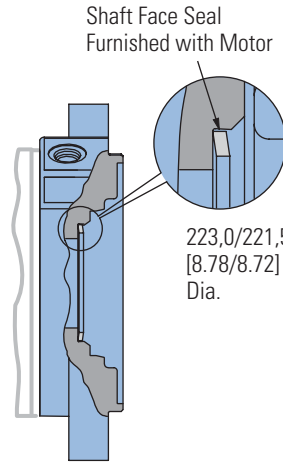
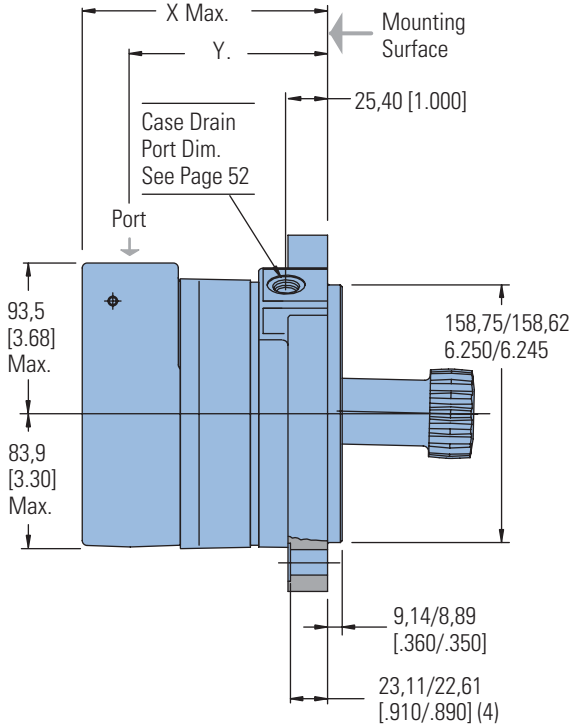

## Mating Coupling Blank Eaton Part No. 13521-003

- C** 116,3 [ 4.58 ] Dia. Max.
- D** 111,8 [ 4.40 ] Dia. Min.
- E** 37,64 [ 1.482 ] Dia.
- F** 136,7 [ 5.38 ] Max.
- G** 131,6 [ 5.18 ] Min. Full Form Dia.
- H** 64,8 [ 2.55 ]
- J** 26,4 [ 1.04 ]
- K** 109,7 [ 4.32 ] Max.
- L** 104,6 [ 4.12 ] Min. Full Form Dia.
- M** 92,58 [ 3.645 ] Dia.
- N** 73,28 [ 2.885 ] Dia.

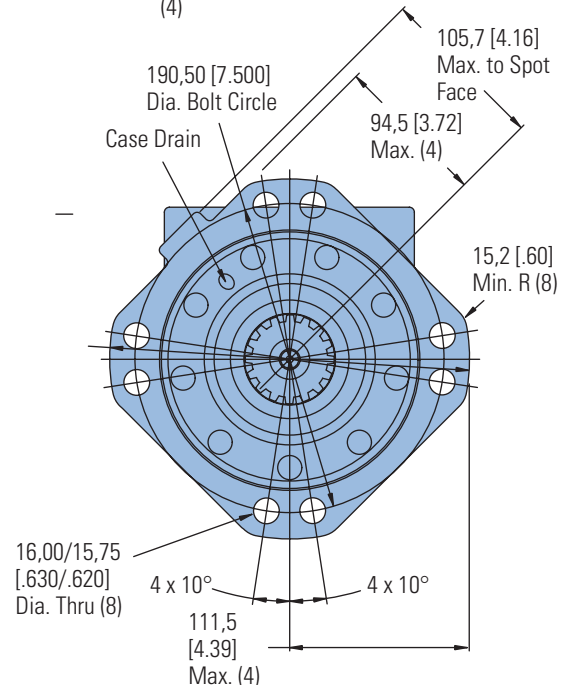
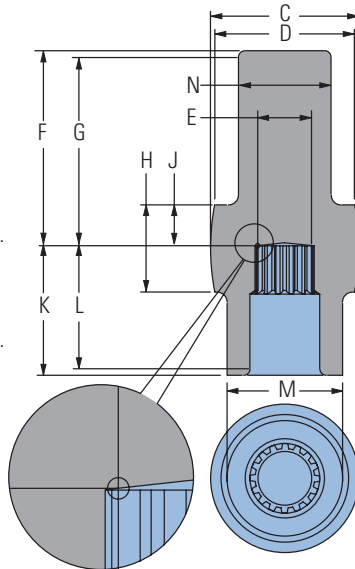

## BEARINGLESS MOTORS

Displacement cm <sup>3</sup> /r [in <sup>3</sup> /r]	X mm [inch]	Y mm [inch]
630 [38.6]	161,5 [6.36]	130,3 [5.13]
805 [48.6]	172,5 [6.79]	141,2 [5.56]
990 [60.5]	184,4 [7.26]	153,4 [6.04]
1245 [76.0]	200,7 [7.90]	169,7 [6.68]
1560 [95.0]	220,5 [8.68]	189,5 [7.46]



# VIS 45 Series

## Installation Information

### Bearingless

- 1 Internal spline in mating part to be per spline data. Specification material to be ASTM A304, 8620H carburize to a hardness of 59-62 HRC with case depth (to 50HRC) of 0,76 -1,27 [.030 -.050]. Dimensions apply after heat treat.
- 2 Mating part to have critical dimensions as shown. Oil holes must be provided and open for proper oil circulation.
- 3 Seal to be furnished with motor for proper oil circulation thru splines.
- 4 Dimension indicated applies within area shown.

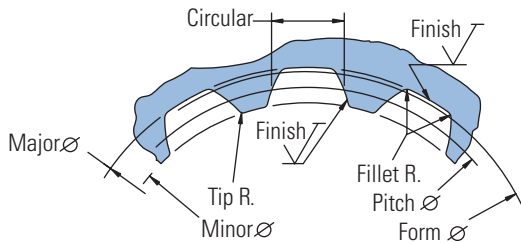
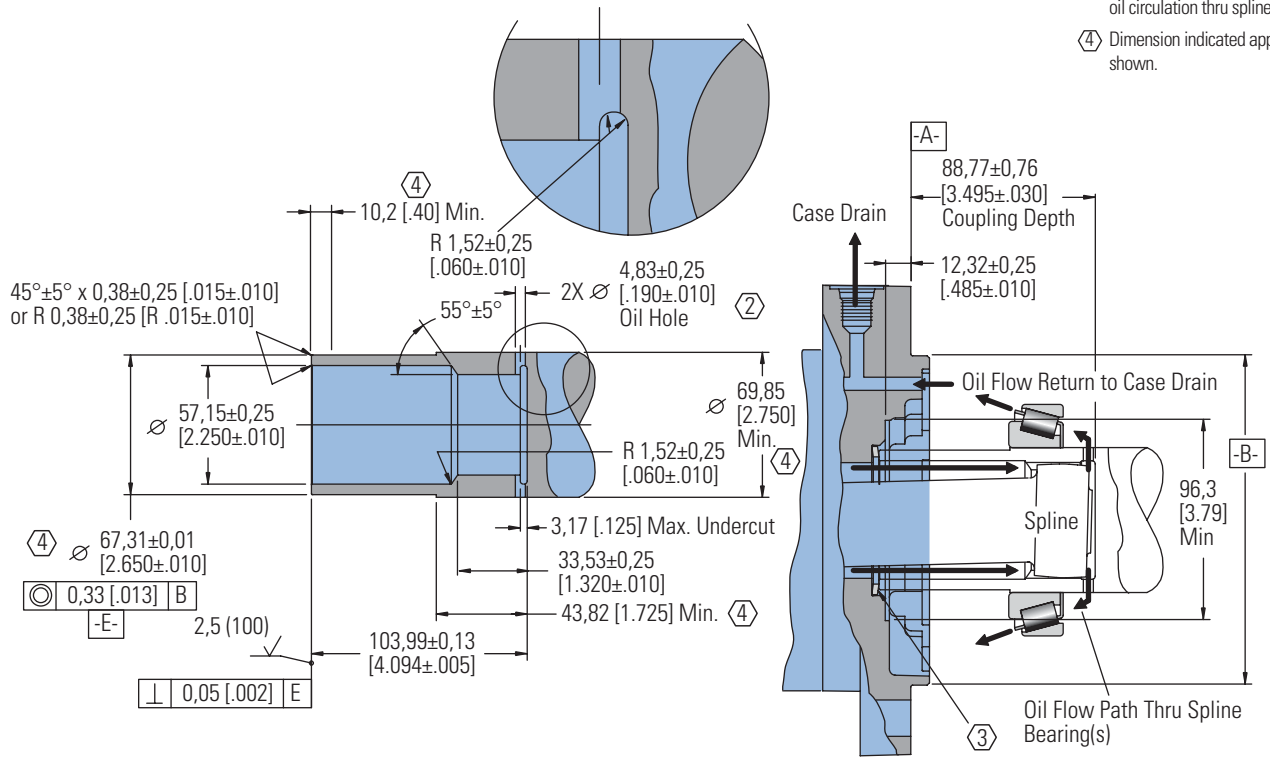

Spline Pitch.....	8/16
Pressure Angle.....	30°
Number of teeth.....	16
Class of Fit.....	Ref. 5
Type of Fit.....	Side
Pitch Diameter.....	Ref. 50,8000 [2.000000] $\text{Ⓞ} 0,33 [.013] B$
Base Diameter.....	Ref. 43,994090032 [1.7320508]
Major Diameter.....	56,34±0,15 [2.218±.006]
Min. Minor Diameter.....	48,44±0,08 [1.907±.003]
Form Diameter, Min.....	55,22 [2.174]
Fillet Radius.....	1,02±0,25 [.040±.010]
Tip Radius.....	0,38±0,13 [.015±.005]
Finish.....	1,6 (63)
Involute Profile Variation.....	+0,000 -0,025 [+0.000 -.0010]
Total Index Variation.....	0,041 [.0016]
Lead Variation.....	0,015 [.0006]
Circular Space Width:	
Maximum Actual.....	6,180 [.2433]
Minimum Effective.....	6,048 [.2381]
Maximum Effective.....	Ref. 6,099 [.2401]
Minimum Actual.....	Ref. 6,114 [.2407]
Dimension Between Two Pins.....	Ref. 42,659 ±0,05 [1.6795±.0020]
Pin Diameter.....	6,223 [.2450]

# VIS 45 Series

## Dimensions Shafts

### Splined

#### 70 mm 22 Tooth Splined

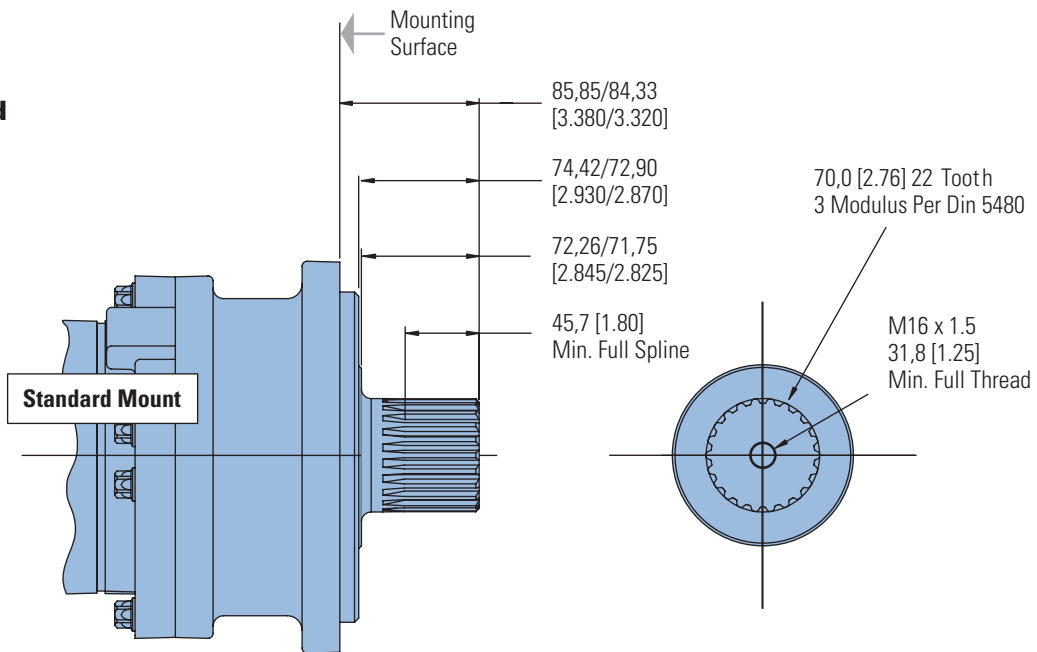

#### 2-3/4 Inch 32 Tooth Splined

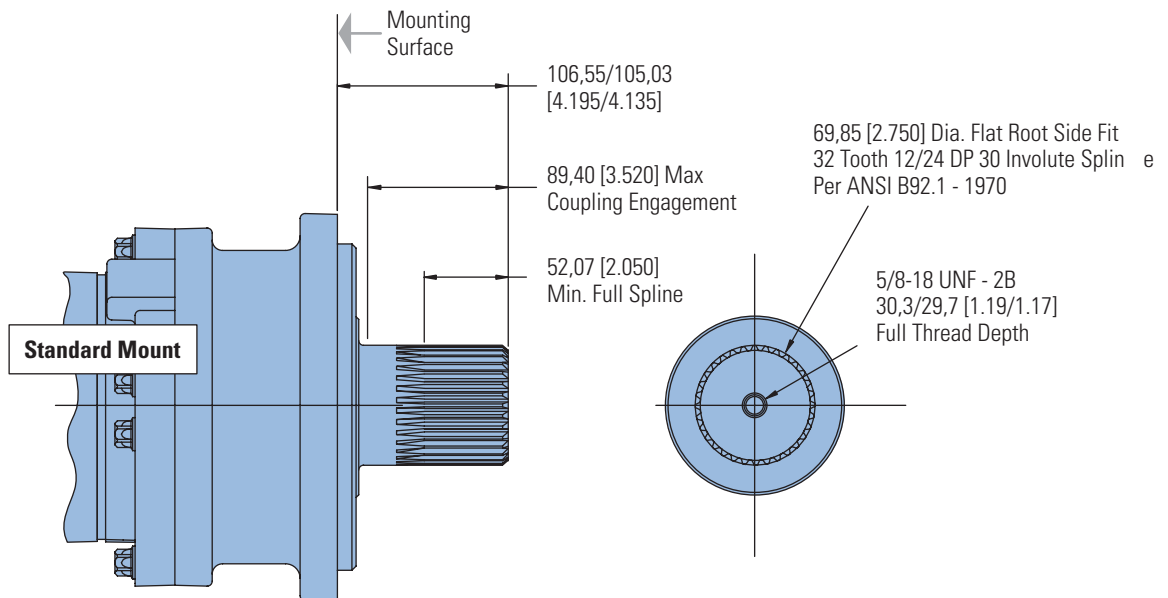

# VIS 45 Series

## Dimensions Shafts

Keyed

### 2-5/8 Inch Straight

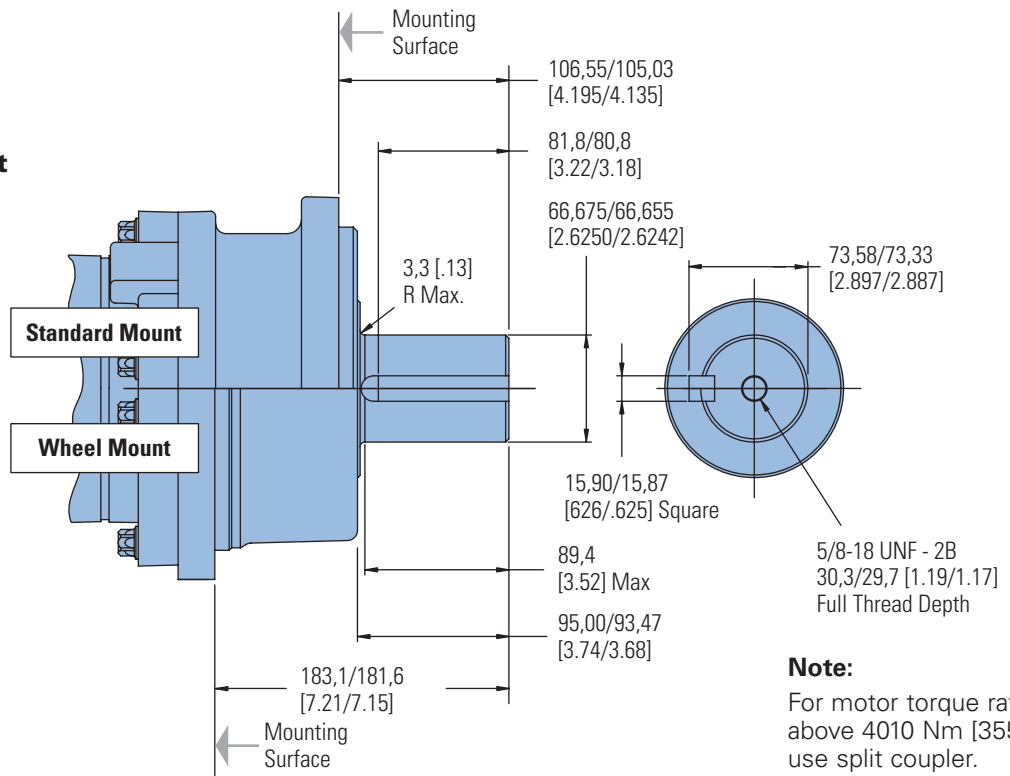

### 60 mm Tapered

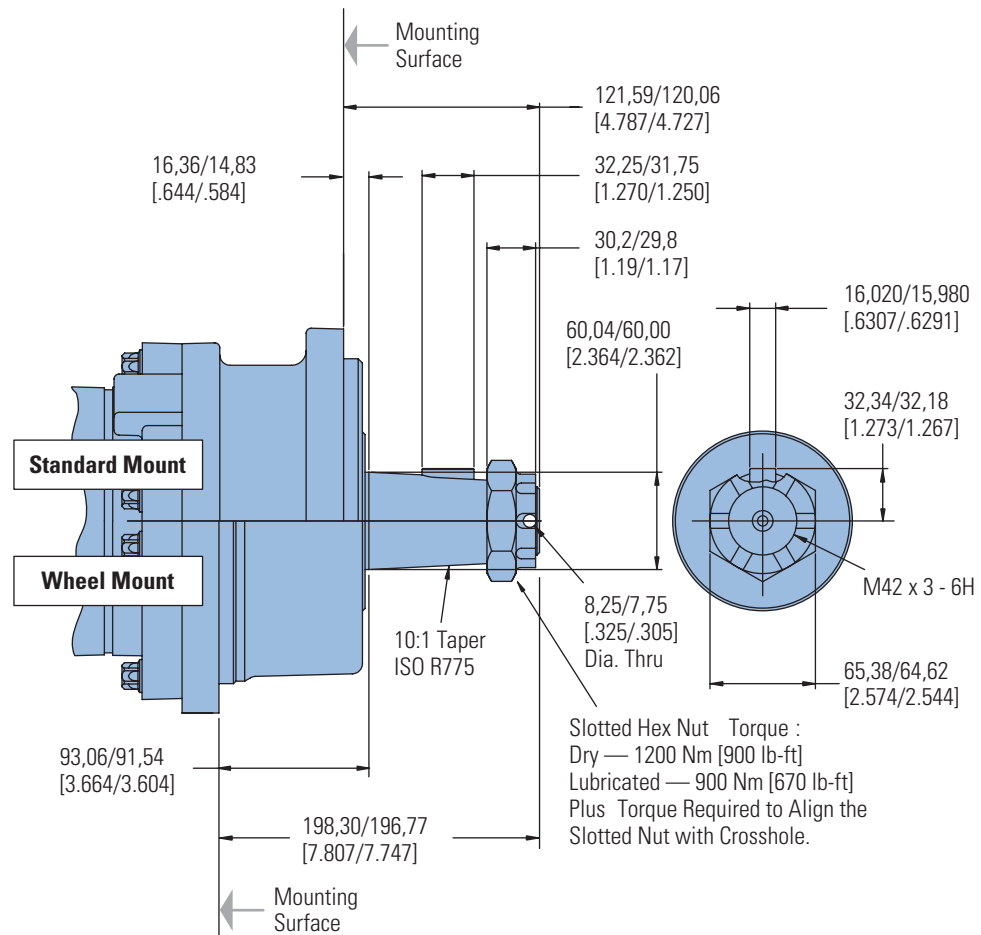

# VIS 45 Series

## Side Load Capacity

These curves indicate the radial load capacity on the motor shaft(s) at various locations.

**The curve is based on B 10 bearing life (2000 hours or 12,000,000 shaft revolutions at 100 RPM) at rated output torque.**

To determine radial load at speeds other than 100 RPM, multiply the load values given on the bearing curve by the factors in the chart below.

RPM	Multiplication Factor
50	1.23
100	1.00
200	0.81
300	0.72
400	0.66
500	0.62
600	0.58
700	0.56
800	0.54

For 3,000,000 shaft revolutions or 500 hours — Increase these shaft loads 52%.

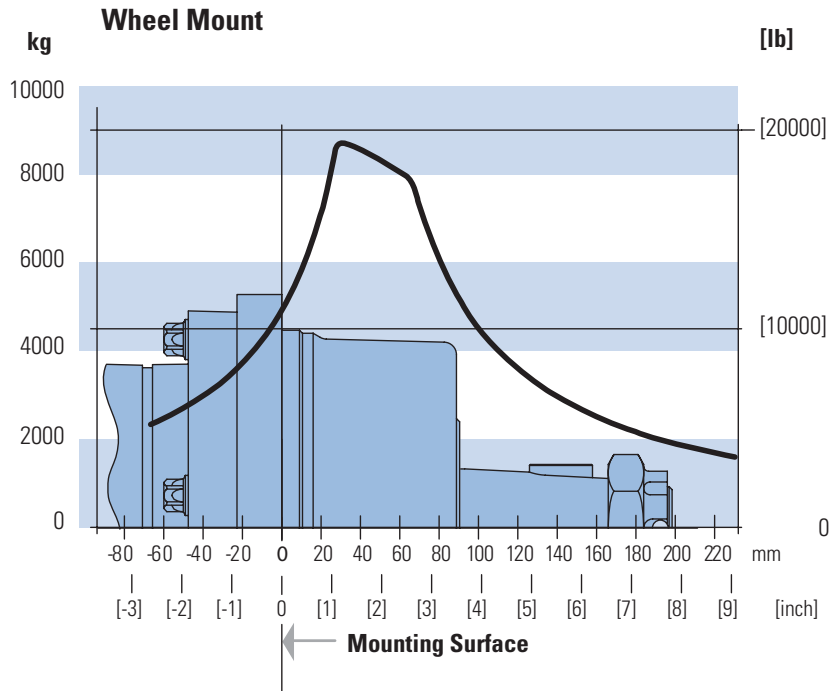
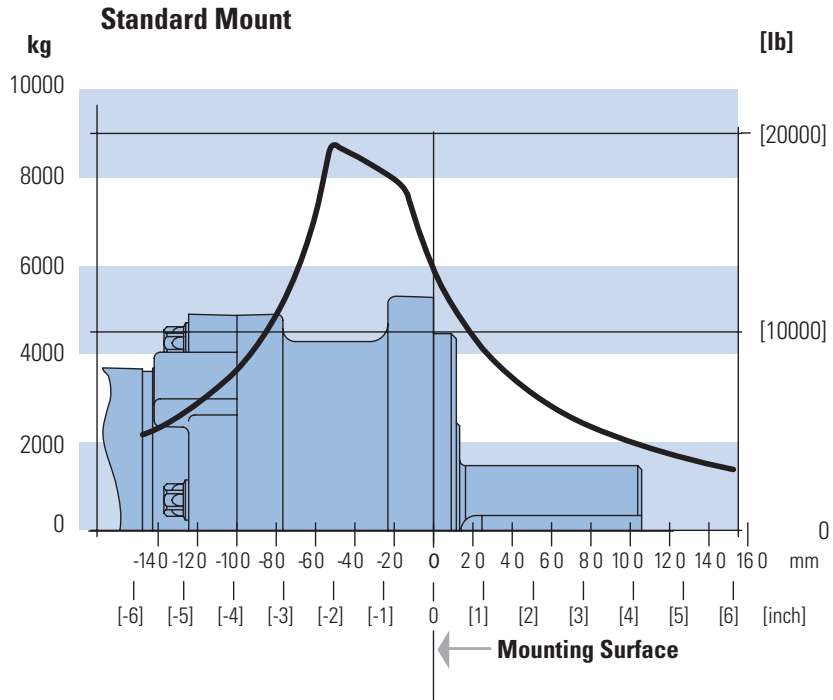

# VIS 45 Series

Product Numbers

Closed Loop

Use three-digit prefix (155-, 156-, or 157-) plus four-digit number from charts for complete product number (ex: 157-0034).

**Orders will not be accepted without the three-digit prefix.**

## SAE

MOUNTING	SHAFT	PORT SIZE	DISPL. cm <sup>3</sup> /r [in <sup>3</sup> /r] / PRODUCT NUMBER				
			630 [38.6]	805 [48.6]	990 [60.5]	1245 [76.0]	1560 [95.0]
Standard	2-5/8 inch Straight	1-5/16-12 UNF O-ring (2) 9/16-18 UNC Drain Port (1)	155-0107	-0108	-0109	-0110	-0111
	60 mm Tapered	1-5/16-12 UNF O-ring (2) 9/16-18 UNC Drain Port (1)	155-0114	-0115	-0116	-0117	-0118
	70 mm 22 Tooth Splined	1-5/16-12 UNF O-ring (2) 9/16-18 UNC Drain Port (1)	155-0121	-0122	-0123	-0124	-0125
	2-3/4 inch 32 Tooth Splined	1-5/16-12 UNF O-ring (2) 9/16-18 UNC Drain Port (1)	155-0128	-0085	-0129	-0130	-0131
Wheel	2-5/8 inch Straight	1-5/16-12 UNF O-ring (2) 9/16-18 UNC Drain Port (1)	156-0039	-0040	-0041	-0042	-0043
	60 mm Tapered	1-5/16-12 UNF O-ring (2) 9/16-18 UNC Drain Port (1)	156-0046	-0047	-0048	-0049	-0050
Bearingless	(8 Bolt)	1-5/16-12 UNF O-ring (2) 9/16-18 UNC Drain Port (1)	157-0066	-0067	-0068	-0069	-0070
	(4 Bolt)	1-5/16-12 UNF O-ring (2) 9/16-18 UNC Drain Port (1)	157-0004	-	-	-	-

157-0004

## ISO

MOUNTING	SHAFT	PORT SIZE	DISPL. cm <sup>3</sup> /r [in <sup>3</sup> /r] / PRODUCT NUMBER				
			630 [38.6]	805 [48.6]	990 [60.5]	1245 [76.0]	1560 [95.0]
Standard	2-5/8 inch Straight	G 1 (BSP) (2) G 1/4 (BSP) Drain Port (1)	155-0134	-0135	-0136	-0137	-0138
	60 mm Tapered	G 1 (BSP) (2) G 1/4 (BSP) Drain Port (1)	155-0141	-0142	-0143	-0144	-0145
	70 mm 22 Tooth Splined	G 1 (BSP) (2) G 1/4 (BSP) Drain Port (1)	155-0148	-0149	-0150	-0151	-0152
	2-3/4 inch 32 Tooth Splined	G 1 (BSP) (2) G 1/4 (BSP) Drain Port (1)	155-0155	-0156	-0157	-0158	-0159
Wheel	2-5/8 inch Straight	G 1 (BSP) (2) G 1/4 (BSP) Drain Port (1)	156-0053	-0054	-0055	-0056	-0057
	60 mm Tapered	G 1 (BSP) (2) G 1/4 (BSP) Drain Port (1)	156-0060	-0061	-0062	-0063	-0064
Bearingless	(8 Bolt)	G 1 (BSP) (2) G 1/4 (BSP) Drain Port (1)	157-0074	-0075	-0076	-0077	-0078
	(4 Bolt)	G 1 (BSP) (2) G 1/4 (BSP) Drain Port (1)	157-0081	-	-	-	-

157-0081

### Note:

The product numbers on this page are for motors used in closed loop circuits. They include a back-pressure relief valve that is set at 15,2 bar [220 PSI].

- A case drain is required for all closed loop VIS motor applications.
- The maximum case pressure for the VIS motor is 3,5 bar [50 PSI].

# VIS 45 Series

## Model Code

The following 16 - digit coding system has been developed to identify all of the configuration options for the VIS 45 motor. Use this model code to specify a motor with the desired features. All 16 digits of the code must be present when ordering. You may want to photocopy the matrix below to ensure that each number is entered in the correct box.

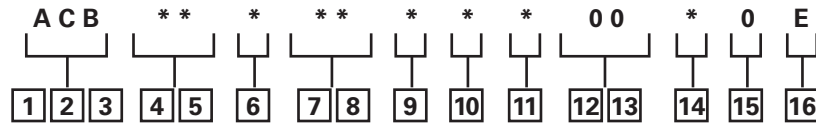

**1, 2, 3 Product Series**  
**ACB** – VIS 45 Motor

**4, 5 Displacement**  
**cm<sup>3</sup>/r [in<sup>3</sup>/r]**

**39** – 630 [38.6]  
**49** – 805 [48.6]  
**60** – 990 [60.5]  
**76** – 1245 [76.0]  
**95** – 1500 [95.0]

**6 Mounting Type**

**A** – 4 Bolt Bearingless  
 158,70 [6.250] Pilot Dia.  
 With 9,07 [.355] Pilot Length  
 and 17,53 [.690] Dia holes  
 on 190,50 [7.500] Dia. B. C.  
 - Max. Torque Allowed 3615  
 Nm [32000 lb - in] (Displ.  
 Code 32, 35, 39 Only)

**C** – 8 Bolt Bearingless  
 158,70 [6.250] Pilot Dia.  
 With 9,07 [.355] Pilot Length  
 and 17,53 [.690] Dia holes  
 on 190,50 [7.500] Dia. Bolt  
 Circle

**D** – 4 Bolt Wheel Mount  
 200,0 [7.87] Pilot Dia. With  
 9,0 [.35] Pilot Length and  
 20,57 [.810] Dia. Holes on  
 250,0 [9.84] Dia. Bolt Circle

**H** – 4 Bolt Standard Mount  
 200,0 [7.87] Pilot Dia. With  
 9,0 [.35] Pilot Length and  
 20,57 [.810] Dia. Holes on  
 250,00 [9.84] Dia. Bolt Circle

**7, 8 Output Shaft**

**00** – None (Bearingless)  
**05** – 2-5/8 inch Dia. Straight  
 Shaft with 5/8-18 UNF-2B  
 Thread in End and 15,88  
 [.625] Sq. X 81,3 [3.20]  
 Straight Key  
**06** – 70 mm Dia. 22 Tooth  
 3 Modulus Splined Shaft Per  
 DIN 5480 with M16 X 1,5  
 Thread in End

**08** – 2-3/4 inch Dia. Flat  
 Root Side Fit 32 Tooth 12/24  
 DP 30°. Involute Spline with  
 5/8-18 UNF-2B Thread in End

**09** – 60 mm Dia. 10:1  
 Tapered Shaft Per ISO R775  
 with M42 x 3 - 6H Threaded  
 Shaft End, 16W x 10H x 32L  
 [.630W x .394H x 1.260L]

**9 Ports**

**A** – 1-5/16-12 UN-2B O-ring  
 Port, Accepts Fittings for  
 SAE J1926/1

**B** – G 1 (BSP) Ports, Accepts  
 Fittings with Elastomeric or  
 Deformable Metallic Sealing  
 Member Per DIN 3852

**10 Case Flow Options**

**B** – Check valve with  
 leakage orifice, no case  
 drain (for Open Loop only)

**D** – Shuttle Valve with Side  
 Facing 9/16-18 UNF-2B,  
 O-ring Port Case Drain,  
 Accepts Fittings for SAE  
 J1926/1, Case Drain  
 Required

**H** – Shuttle Valve with Side  
 Facing G 1/4 (BSP) Port  
 Case Drain, Case Drain  
 Required

**11 Back-Pressure Relief**

**0** – None (for Open Loop  
 Only)  
**1** – Set at 15,2 bar [220 psi]  
 (for Servo Pumps)  
**3** – Set at 4,5 bar [65 psi]  
 (for Manual Pumps)  
**4** – Set at 20,7 bar [300 PSI]  
 (for High Pressure Servo  
 Pumps)

**12, 13 Special Features**

**00** – None

**14 Paint/ Special  
 Packaging**

**0** – Primer, Individual Box  
**A** – Low Gloss Black Primer,  
 Individual Box  
**B** – No Paint, Bulk Box  
 Option  
**C** – Low Gloss Black Primer,  
 Bulk Box Option

**15 Eaton Assigned  
 Code when Applicable**

**0** – Assigned Code

**16 Eaton Assigned  
 Design Code**

**E** – Assigned Design Code

# VIS 45 Series Two-speed

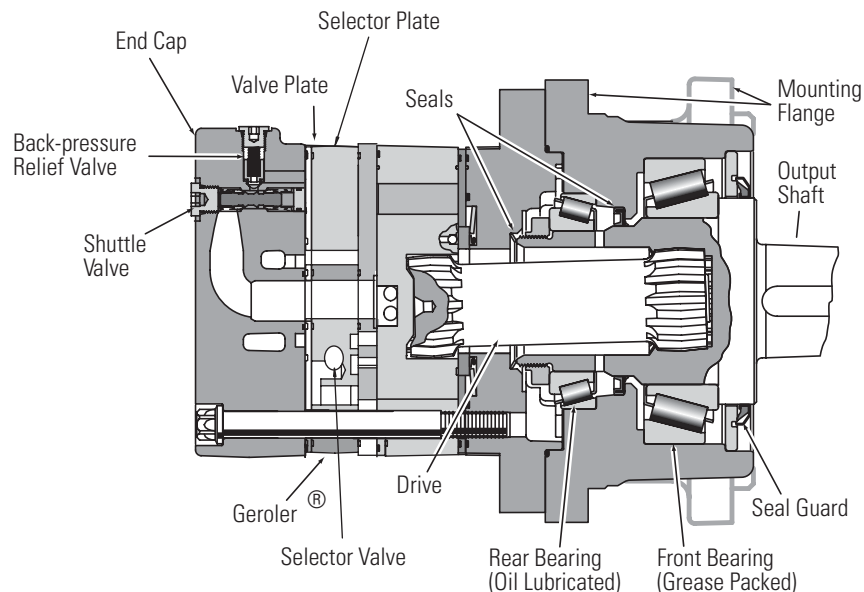

## Specifications

VIS 45 Series motors are available with an integral two-speed feature that allows the operator to shift the motor between low speed high torque (LSHT) mode and high speed low torque (HSLT) mode. In the LSHT mode, output torque and rotation speed values are equal to those of the conventional VIS 45 motor. In the HSLT mode motor displacement is reduced by one third, resulting in a fifty percent increase in rotation speed and a torque output reduction of one third. The VIS 45 two speed motor is bidirectional. It will function with equal shaft output in either rotation direction (CW or CCW) in both LSHT and HSLT modes. Shift on the fly technology allows full-power operation throughout the full duration of the shift.

Changing between modes is accomplished by changing the displacement in a ratio of 1 to 1.5. An external two-position three-way control valve is required for shifting pressure to the pilot port between low pressure (LSHT mode) and pilot signal pressure (HSLT mode). An integral selector valve shifts the motor from LSHT mode to HSLT mode. Initially, low pressure is supplied to the pilot port. The selector valve is biased to LSHT mode by a return spring. When pilot signal pressure is supplied to the pilot port and 3,5 Δbar [50 ΔPSI] is reached, the selector valve overcomes return spring force and the shifts the spool to select HSLT mode. Oil on the opposite side of the spool is drained to tank via the drain port. The pressure difference between the pilot port and drain port must be maintained to keep the motor in the high speed mode. When pilot pressure

is removed from the pilot port, the pressure in the pilot end of the spool valve is relieved and drained back through the control valve and the return spring forces the spool valve to LSHT position.

Pilot pressure may come from any source that will provide uninterrupted pressure during the high-speed mode operation. Allowable pilot pressure must be at least 3,5 Δbar [50 ΔPSI] and may be as high as full operating pressure of the motor.

All VIS 45 Series two speed motors are equipped with a return line shuttle for closed circuit applications as standard equipment. All options available on the conventional VIS 45 are also available on VIS 45 two speed motors.

## Performance Data

In the LSHT mode, torque and speed values are equal to those of the conventional VIS 45 motor. In the HSLT mode, rotation speed is increased by fifty percent and torque output is reduced by one third.

The VIS 45 two speed motor will function with equal shaft output in either rotation direction (CW or CCW) in both LSHT and HSLT modes.

# VIS 45 Series

## Two-speed

Dimensions

Standard Mount

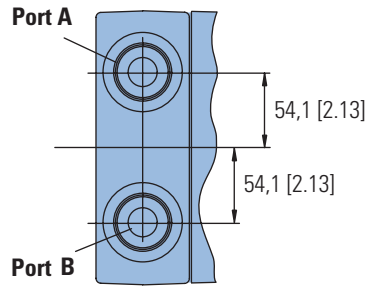

### Ports

- 1-5/16-12 UN-2B SAE O-ring Ports (2)
- 9/16-18 UNF-2B SAE O-ring Case Drain Port (1)
- 7/16 -20 UNF -2B SAE O-ring Shift Ports (2)
- or
- G 1 (BSP) O-ring Ports (2)
- G 1/4 (BSP) O-ring Case Drain Port (1)
- 7/16 -20 UNF -2B SAE O-ring Shift Ports (2)

### Standard Rotation Viewed from Shaft End

- Port A Pressurized — CW
- Port B Pressurized — CCW

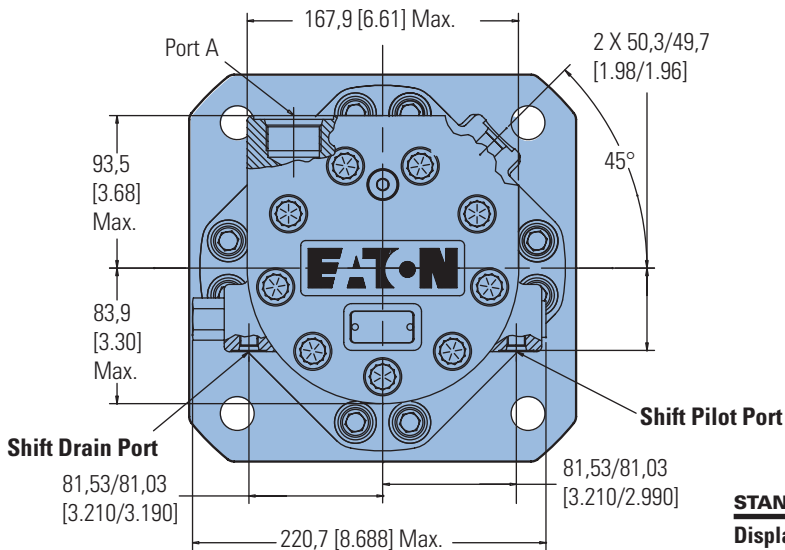
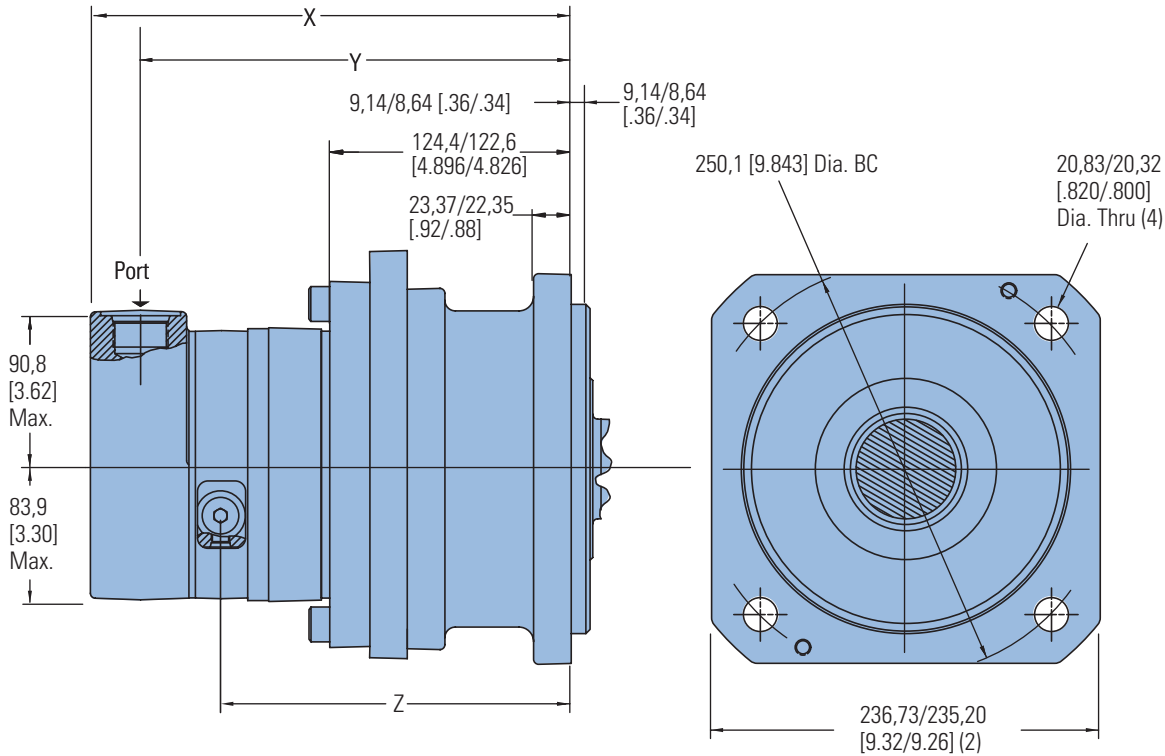

### STANDARD MOUNT

Displacement cm <sup>3</sup> /r [in <sup>3</sup> /r]	X mm [inch]	Y mm [inch]	Z mm [inch]
630 [38.6]	295,5 [11.63]	263,2 [10.36]	216,3 [8.51]
805 [48.6]	305,9 [12.04]	273,6 [10.77]	226,7 [8.92]
990 [60.5]	318,3 [12.53]	286,0 [11.26]	239,1 [9.41]
1245 [76.0]	334,3 [13.16]	302,0 [11.89]	255,1 [10.04]
1560 [95.0]	353,3 [13.94]	321,0 [12.67]	274,1 [10.82]



# VIS 45 Series

## Two-speed

Dimensions

Wheel Mount

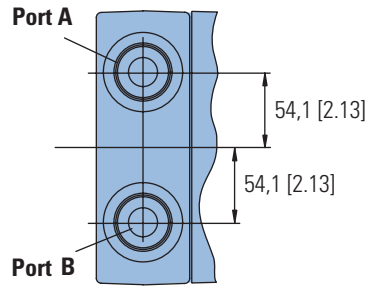

### Ports

- 1-5/16-12 UN-2B SAE O-ring Ports (2)
- 9/16-18 UNF-2B SAE O-ring Case Drain Port (1)
- 7/16-20 UNF -2B SAE O-ring Shift Ports (2)
- or
- G 1 (BSP) O-ring Ports (2)
- G 1/4 (BSP) O-ring Case Drain Port (1)
- 7/16-20 UNF -2B SAE O-ring Shift Ports (2)

### Standard Rotation Viewed from Shaft End

- Port A Pressurized — CW
- Port B Pressurized — CCW

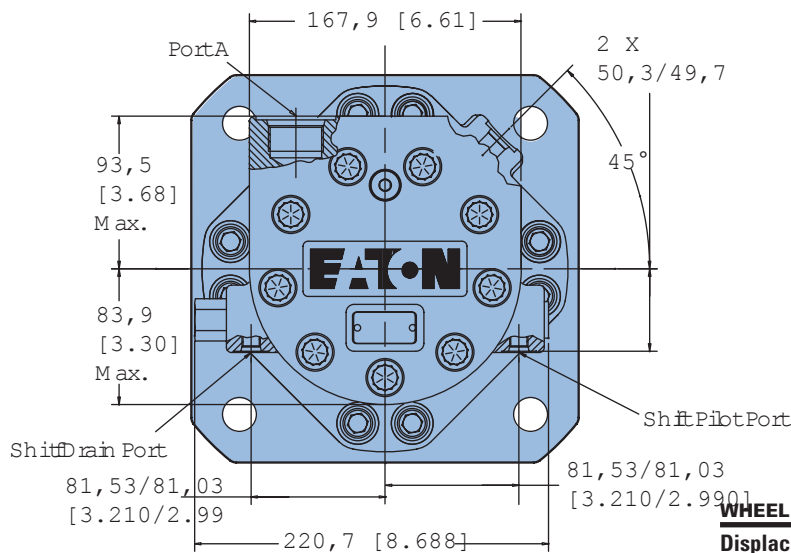
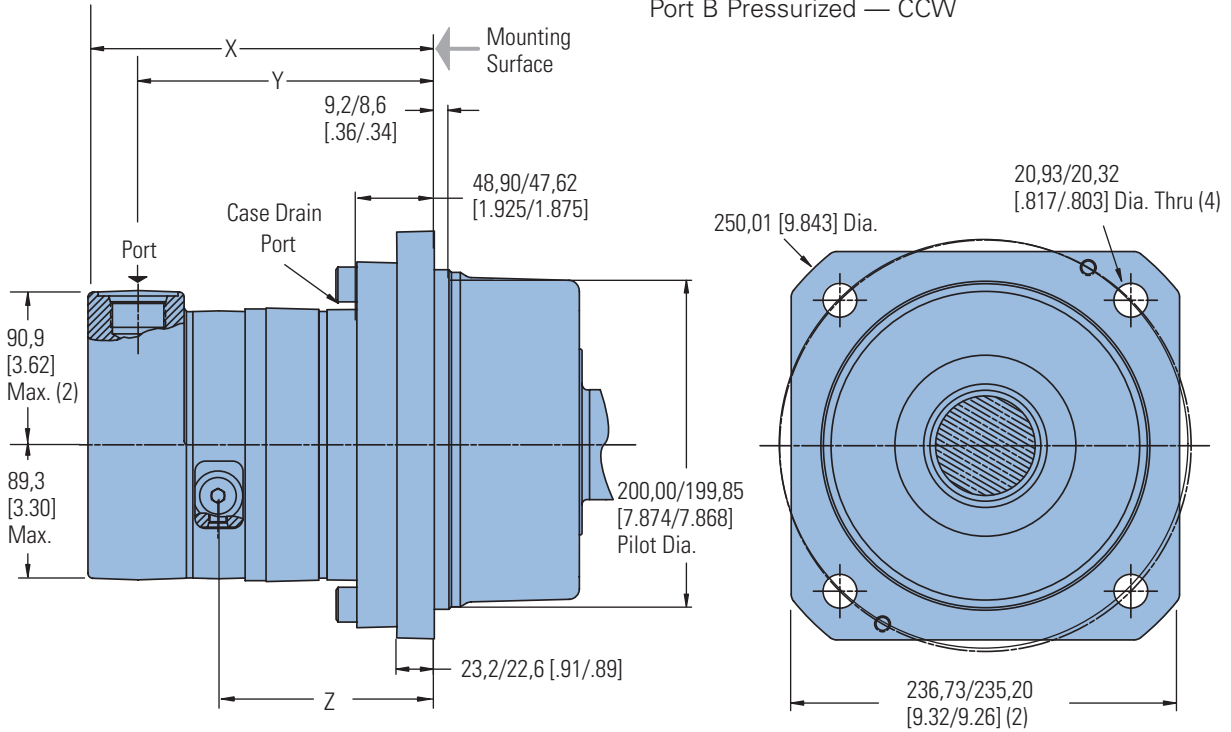

### WHEEL MOUNT

Displacement cm <sup>3</sup> /r [in <sup>3</sup> /r]	X mm [inch]	Y mm [inch]	Z mm [inch]
630 [38.6]	218,8 [8.61]	186,5 [7.34]	139,6 [5.49]
805 [48.6]	229,2 [9.02]	196,9 [7.75]	150,0 [5.90]
990 [60.5]	241,6 [9.51]	209,4 [8.24]	162,4 [6.39]
1245 [76.0]	257,6 [10.14]	225,6 [8.88]	178,4 [7.02]
1560 [95.0]	276,6 [10.92]	245,4 [9.66]	197,4 [7.80]

D-2

# VIS 45 Series

## Two-speed

Dimensions  
Bearingless

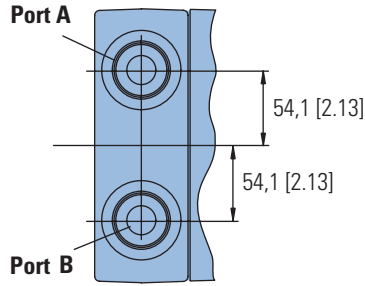

### Ports

- 1-1/16-12 UN-2B SAE O-ring Ports (2)
- 9/16-18 UNF-2B SAE O-ring Case Drain Port (1)
- 7/16 -20 UNF -2B SAE O-ring Shift Ports (2)
- Or
- G 3/4 (BSP) O-ring Ports (2)
- G 1/4 (BSP) O-ring Case Drain Port (1)
- 7/16 -20 UNF -2B SAE O-ring Shift Ports (2)

### Standard Rotation Viewed from Drive End

- Port A Pressurized — CW
- Port B Pressurized — CCW

For VIS 45 two-speed bearingless motor application information, contact your Eaton representative (mating coupling blanks available from Eaton Hydraulics).

### Note:

After machining blank, part must be hardened per Eaton specification.

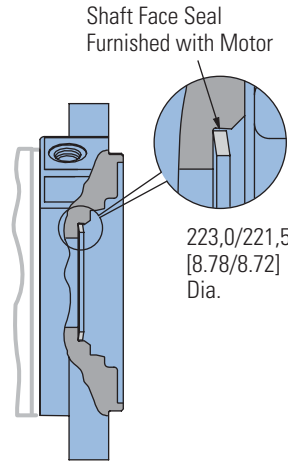
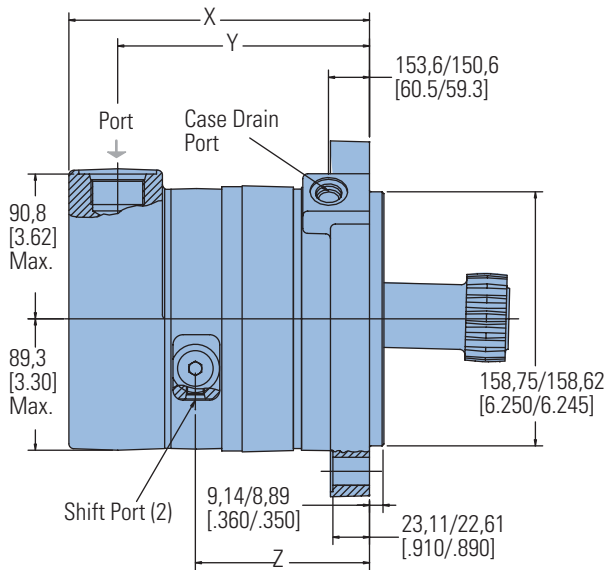

### Mating Coupling Blank Eaton Part No. 13521-003

- C** 116,3 [ 4.58 ] Dia. Max.
- D** 111,8 [ 4.40 ] Dia. Min.
- E** 37,64 [ 1.482 ] Dia.
- F** 136,7 [ 5.38 ] Max.
- G** 131,6 [ 5.18 ] Min. Full Form Dia.
- H** 64,8 [ 2.55 ]
- J** 26,4 [ 1.04 ]
- K** 109,7 [ 4.32 ] Max.
- L** 104,6 [ 4.12 ] Min. Full Form Dia.
- M** 92,58 [ 3.645 ] Dia.
- N** 73,28 [ 2.885 ] Dia.

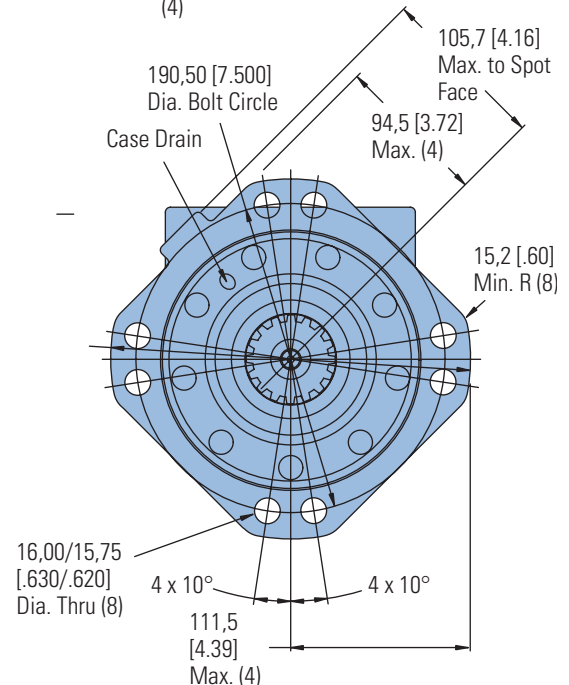
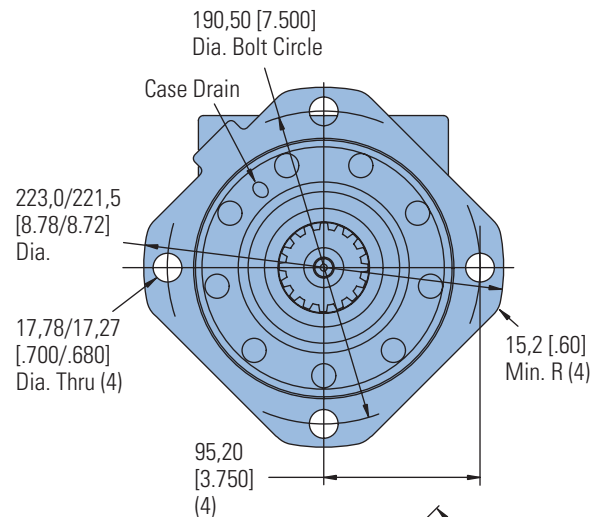
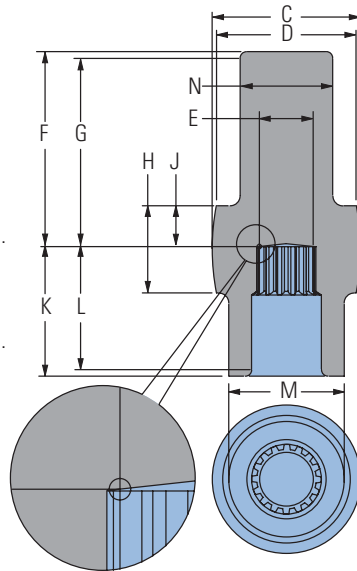

### BEARINGLESS MOTORS

Displacement cm <sup>3</sup> /r [in <sup>3</sup> /r]	X mm [inch]	Y mm [inch]	Z mm [inch]
630 [38.6]	196,1 [7.72]	165,9 [6.53]	116,9 [4.60]
805 [48.6]	206,5 [8.13]	176,3 [6.94]	127,3 [5.01]
990 [60.5]	218,9 [8.62]	188,8 [7.43]	139,7 [5.50]
1245 [76.0]	235,2 [9.26]	205,0 [8.07]	156,0 [6.14]
1560 [95.0]	255,0 [10.04]	224,8 [8.85]	175,8 [6.92]

# VIS 45 Series Two-speed

## Product Numbers

(Closed Loop)

Use digit prefix—173-,174- or 183- plus four digit number from charts for complete product number—

Example: 173-0013.

**Orders will not be accepted without three digit prefix.**

### SAE

MOUNTING	SHAFT	PORT SIZE	DISPL. cm <sup>3</sup> /r [in <sup>3</sup> /r] / PRODUCT NUMBER				
			630 [38.6]	805 [48.6]	990 [60.5]	1245 [76.0]	1560 [95.0]
Standard	2-5/8 inch Straight	1-5/16-12 UNF O-ring (2) 9/16-18 UNC Drain Port (1)	174-0006	-0007	-0008	-0009	-0010
	60 mm Tapered	1-5/16-12 UNF O-ring (2) 9/16-18 UNC Drain Port (1)	174-0011	-0012	-0013	-0014	-0015
	70 mm 22 Tooth Splined	1-5/16-12 UNF O-ring (2) 9/16-18 UNC Drain Port (1)	174-0016	-0017	-0018	-0019	-0020
Wheel	2-3/4 inch 32 Tooth Splined	1-5/16-12 UNF O-ring (2) 9/16-18 UNC Drain Port (1)	174-0021	-0022	-0023	-0024	-0025
	2-5/8 inch Straight	1-5/16-12 UNF O-ring (2) 9/16-18 UNC Drain Port (1)	183-0006	-0007	-0008	-0009	-0010
	60 mm Tapered	1-5/16-12 UNF O-ring (2) 9/16-18 UNC Drain Port (1)	183-0011	-0012	-0013	-0014	-0015
Bearingless	(8 Bolt)	1-5/16-12 UNF O-ring (2) 9/16-18 UNC Drain Port (1)	173-0008	-0009	-0010	-0011	-0012
	(4 Bolt)	1-5/16-12 UNF O-ring (2) 9/16-18 UNC Drain Port (1)	173-0013	-	-	-	-

173-0013

### ISO

MOUNTING	SHAFT	PORT SIZE	DISPL. cm <sup>3</sup> /r [in <sup>3</sup> /r] / PRODUCT NUMBER				
			630 [38.6]	805 [48.6]	990 [60.5]	1245 [76.0]	1560 [95.0]
Standard	2-5/8 inch Straight	G 1 (BSP) (2) G 1/4 (BSP) Drain Port (1)	174-0026	-0027	-0028	-0029	-0030
	60 mm Tapered	G 1 (BSP) (2) G 1/4 (BSP) Drain Port (1)	174-0031	-0032	-0033	-0034	-0035
	70 mm 22 Tooth Splined	G 1 (BSP) (2) G 1/4 (BSP) Drain Port (1)	174-0036	-0037	-0038	-0039	-0040
Wheel	2-3/4 inch 32 Tooth Splined	G 1 (BSP) (2) G 1/4 (BSP) Drain Port (1)	174-0041	-0042	-0043	-0044	-0045
	2-5/8 inch Straight	G 1 (BSP) (2) G 1/4 (BSP) Drain Port (1)	183-0016	-0017	-0018	-0019	-0020
	60 mm Tapered	G 1 (BSP) (2) G 1/4 (BSP) Drain Port (1)	183-0021	-0022	-0023	-0024	-0025
Bearingless	(8 Bolt)	G 1 (BSP) (2) G 1/4 (BSP) Drain Port (1)	173-0014	-0015	-0016	-0017	-0018
	(4 Bolt)	G 1 (BSP) (2) G 1/4 (BSP) Drain Port (1)	173-0019	-	-	-	-

173-0019

#### Note:

The product numbers on this page are for motors used in closed loop circuits. They include a back-pressure relief valve that is set at 15,2 bar [220 PSI].

- A case drain is required for all closed loop VIS motor applications.
- The maximum case pressure for the VIS motor is 3,5 bar [50 PSI].

# VIS 45 Series Two-speed

## Model Code

The following 18-digit coding system has been developed to identify all of the configuration options for the VIS 45 Two-Speed motor. Use this model code to specify a motor with the desired features. All 18 digits of the code must be present when ordering. You may want to photocopy the matrix below to endure that each number is entered in the correct box.

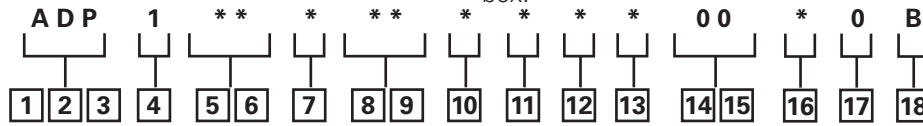

**1, 2, 3 Product Series**  
**ADP** – VIS 45 Two-speed Motor

**4 Eaton Assigned Code**  
**1** – Assigned Code

**5, 6 Displacement**  
**cm<sup>3</sup>/r [in<sup>3</sup>/r]**

**49** – 805 [48.6]  
**60** – 990 [60.5]  
**76** – 1245 [76.0]  
**95** – 1560 [95.0]

**7 Mounting Type**

**A** – 4 Bolt Bearingless  
 158,70 [6.250] Pilot Dia.  
 With 9,07 [.355] Pilot Length  
 and 17,53 [.690] Dia holes  
 on 190,50 [7.500] Dia. B. C.  
 - Max. Torque Allowed 3615  
 Nm [32000 lb-in] (Displ.  
 Code 32, 35, 39 Only)

**C** – 8 Bolt Bearingless  
 158,70 [6.250] Pilot Dia.  
 With 9,07 [.355] Pilot Length  
 and 17,53 [.690] Dia holes  
 on 190,50 [7.500] Dia. Bolt  
 Circle

**D** – 4 Bolt Wheel Mount  
 200,0 [7.87] Pilot Dia. With  
 9,0 [.35] Pilot Length and  
 20,57 [.810] Dia. Holes on  
 250,0 [9.84] Dia. Bolt Circle

**H** – 4 Bolt Standard Mount  
 200,0 [7.87] Pilot Dia. With  
 9,0 [.35] Pilot Length and  
 20,57 [.810] Dia. Holes on  
 250,00 [9.84] Dia. Bolt Circle

**8, 9 Output Shaft**

**00** – None (Bearingless)

**05** – 2-5/8 inch Dia. Straight  
 Shaft with 5/8-18 UNF-2B  
 Thread in End and 15,88  
 [.625] Sq. X 81,3 [3.20]  
 Straight Key

**06** – 70 mm Dia. 22 Tooth  
 3 Modulus Splined Shaft Per  
 DIN 5480 with M16 X 1,5  
 Thread in End

**08** – 2-3/4 inch Dia. Flat  
 Root Side Fit 32 Tooth 12/24  
 DP 30°. Involute Spline with  
 5/8-18 UNF-2B Thread in End

**09** – 60 mm Dia. 10:1  
 Tapered Shaft Per ISO R775  
 with M42 x 3 - 6H Threaded  
 Shaft End, 16W x 10H x 32L  
 [.630W x .394H x 1.260L]

**10 Ports**

**A** – 1-5/16-12 UN-2B O-ring  
 Port, Accepts Fittings for  
 SAE J1926/1

**B** – G 1 (BSP) Straight  
 Thread Ports

**11 Case Flow Options**

**D** – Shuttle Valve with Side  
 Facing 9/16-18 UNF-2B,  
 O-ring Port Case Drain,  
 Accepts Fittings for SAE  
 J1926/1, Case Drain  
 Required

**F** – Shuttle Valve with Side  
 Facing G 1/4 (BSP) Port  
 Case Drain, Case Drain  
 Required

**12 Back-Pressure Relief**

**1** – Set at 15,2 bar [220 psi]  
 (for Servo Pumps)

**3** – Set at 4,5 bar [65 psi]  
 (for Manual Pumps)

**4** – Set at 20,7 bar [300 PSI]  
 (for High Pressure Servo  
 Pumps)

**13 Eaton Assigned Code**

**0** – Assigned Code

**14, 15 Special Features**  
**00** – None

**16 Paint/ Special Packaging**

**0** – Primer, Individual Box

**A** – Low Gloss Black Primer,  
 Individual Box

**B** – No Paint, Bulk Box  
 Option

**C** – Low Gloss Black Primer,  
 Bulk Box Option

**17 Eaton Assigned Code when Applicable**

**0** – Assigned Code

**18 Eaton Assigned Design Code**

**B** – Assigned Design Code

# Notes

Eaton  
Hydraulics Group USA  
14615 Lone Oak Road  
Eden Prairie, MN 55344  
USA  
Tel: 952-937-9800  
Fax: 952-294-7722  
[www.eaton.com/hydraulics](http://www.eaton.com/hydraulics)

Eaton  
Hydraulics Group Europe  
Route de la Longeraie 7  
1110 Morges  
Switzerland  
Tel: +41 (0) 21 811 4600  
Fax: +41 (0) 21 811 4601

Eaton  
Hydraulics Group Asia Pacific  
Eaton Building  
4th Floor, No. 3 Lane 280 Linhong Rd.  
Changning District  
Shanghai 200335  
China  
Tel: (+86 21) 5200 0099  
Fax: (+86 21) 5200 0400

© 2016 Eaton Corporation  
All Rights Reserved  
Printed in USA  
Document No. E-MOLO-MC001-E8  
Supersedes E-MOLO-MC001-E7  
October 2016



*Powering Business Worldwide*