

Leak-Free Load-Control Valve, Size 20

$Q_{\max} = 350 \text{ l/min [92 gpm]}$, $p_{\max} = 420 \text{ bar [6000 psi]}$

leak-proof, two-stage hydraulic, cartridge design

Series CINDY 20-B-C...

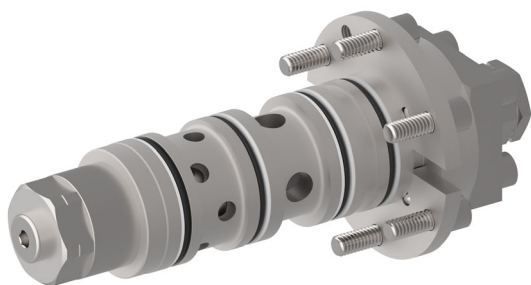

- Two-stage load-control valve and bypass check valve are functionally combined in one coaxial valve assembly
- Leak-free load holding
- Pilot ratio 1:113
- Guaranteed closing force for the load-control assembly → reliable shut-off even with a broken spring
- Various pilot-pressure ranges can be chosen
- Various types of pilot control are available
- Low-noise operation thanks to specially shaped control grooves

1 Description

Whenever large loads are to be precisely moved, placed and held, or work access platforms must maintain their position and withstand high forces, then leak-free load-control valves from the CINDY series are the right solution.

Load-control valves in this series prevent hydraulic actuators from running ahead of the available oil supply. In one

valve, they combine the functions of load-holding, safety and pipe-rupture protection. Leak-free load-control valves in this series are ideally suited for use in high-pressure applications up to 420 bar (6000 psi). With a variety of optional components, the series can be extended and adapted to the requirements of the system.

2 Symbol

2.1 Cartridge design variants

Variant A

Influenced by return-line pressure
(pressure in A is additive to opening pilot pressure).

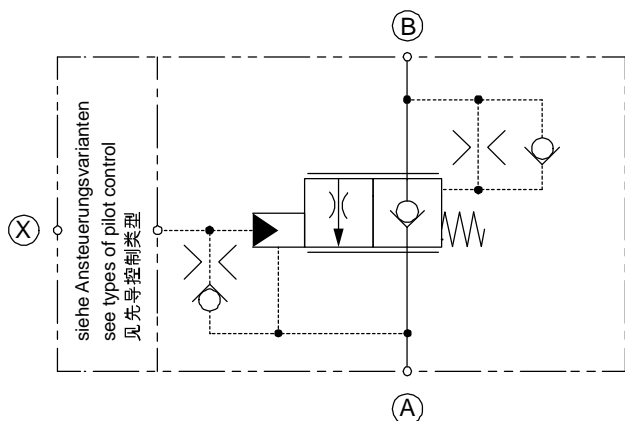

Variant L

Not influenced by return-line pressure
(drain line is required).

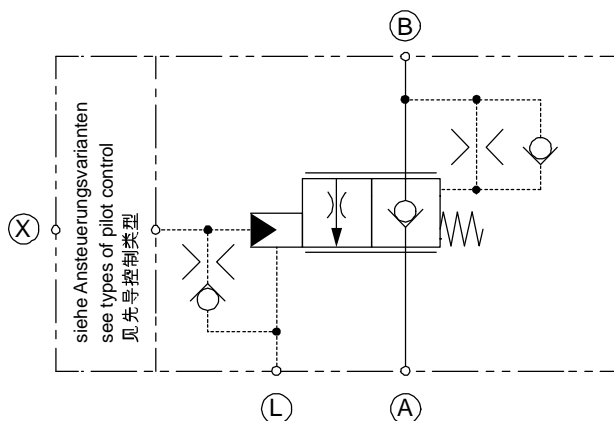

3 Technical data

General characteristics		Description, value, unit	
Designation		leak-free load-control valve	
Design		leak-proof, two-stage hydraulic, cartridge design	
Size		Size 20	
Mounting method		flange mounting 6x hex. socket-head cap screws M8x25 ISO 4762 (DIN 912), – grade 12.9	
Main ports	A, B	Ø 20 mm	[Ø .787 inch] (factory standards)
Control port	X	G ¼"	ISO 1179-1
Drain ports	L1	Ø 6 mm	[Ø .236 inch] (factory standards)
Test ports	MB, MX	G ¼"	ISO 1179-1
Weight		2.7 ... 3.7 kg	[5.95...8.15 lbs]
Mounting attitude		unrestricted	
Ambient temperature range		-25 °C ... +80 °C	[-13 °F ... +176 °F] (others on application)
Surface corrosion protection		Cover: zinc-nickel coating Mounting screws zinc-flake coated (e.g. with Geomet® finish) Flange and cartridge have no surface protection	

Hydraulic characteristics		Description, value, unit	
Maximum operating pressure		420 bar	[6000 psi]
Maximum pressure at the flow- or return port A		420 bar	[6000 psi]
Maximum pressure at the actuator- / load port B		420 bar	[6000 psi]
Maximum pressure at the pilot port X		420 bar	[6000 psi]
Maximum flow rate		350 l/min	[92 gpm]
Flow direction		A → B, free flow through check valve B → A, controlled flow	
Operator type		hydraulic proportional or electro proportional	
Opening pilot ratio		1:113	
Hydraulic fluid		HL and HLP mineral oil to DIN 51 524; for other fluids, please contact BUCHER	
Hydraulic fluid temperature range		- 25 °C ... + 80 °C	[-13 °F ... +176 °F]
Temperature rating of seals	NBR	- 25 °C ... + 100 °C	[-13 °F ... +212 °F]
	FKM	- 20 °C ... + 200 °C	[-4 °F ... +392 °F]
	MIL	- 55 °C ... + 80 °C	[-67 °F ... +176 °F]

Hydraulic characteristics	Description, value, unit
Viscosity range	2.8...1500 mm ² /s (cSt), recommended 10...380 mm ² /s (cSt)
Minimum fluid cleanliness Cleanliness class to ISO 4406 : 1999	class 20/17/14

4 Construction and function

The functions of the control assembly are subdivided into the following positions:

4.1 Neutral position

The load pressure and the compression spring act on the control spool in the closing direction. The valve is closed with no leakage.

4.2 Lifting (flow direction from A → B)

The pump pressure at port A opens the valve against the "light" compression spring and the load. The pilot spool and control spool move together in the opening direction. Oil flows from A → B and the valve functions as a check valve.

4.3 Lowering (flow direction from B → A)

The pilot pressure at port X acts on the pilot piston and against the control springs. The pilot spool opens. As a result, the load pressure B is discharged to port A via the metering grooves in the pilot spool. The progressive characteristic of the pre-opening phase ensures that lowering begins smoothly and without jerks.

If the pilot pressure at port X is increased, the pilot spool opens further. The change in the pressure conditions at the control spool means that it follows the pilot spool in the opening direction. The oil flows from B → A.

Neutral position

(Symbol for 4.1)

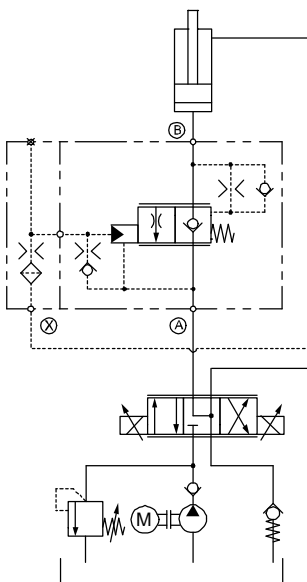

Lifting (A → B)

(Symbol for 4.2)

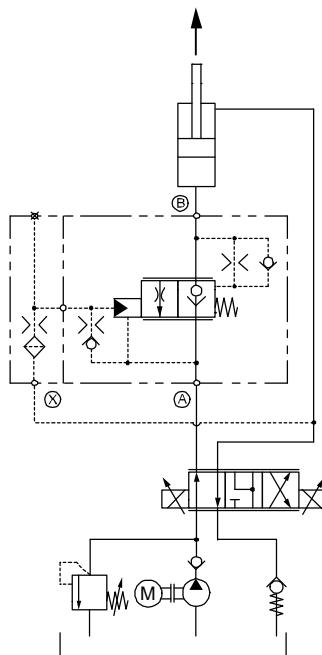

Lowering (B → A)

(Symbol for 4.3)

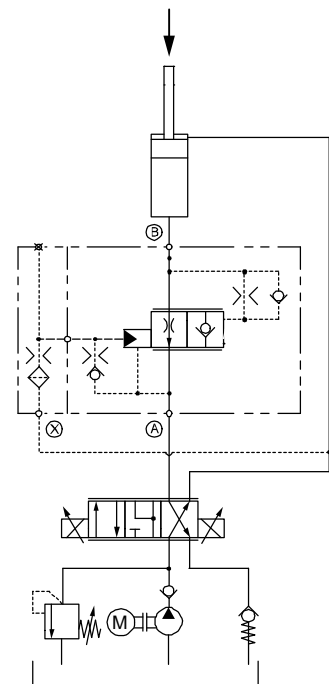

4.4 Types of pilot control

Cover types / applications	Type "G"	Type "D"	Type "K"	Type "H"	Type "R"	Type "E"
Cylinder application (external pilot signal)	✓✓	×	×	✓	✓	✓✓
Cylinder application (pilot signal from opposite line)		✓✓			×	×
Motors / Winches	×		✓✓	×	×	×
Motors for slewing drives	×	✓✓	×	×	×	×

Explanation of symbols: ✓✓ = normal ✓ = possible × = not possible

4.4.1 Standard damping cover, type "G"

Pilot control type "G" is recommended for external control, or with low-oscillation applications. This control cover can only be damped with an inlet orifice. Stroke-dependent damping is not possible with this cover.

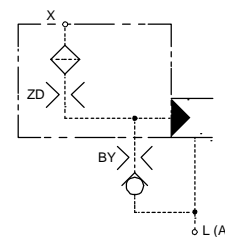

4.4.2 Stroke-dependent damping cover, type "D"

The type "D" cover is recommended for handling pilot signals that come from the opposite actuator line and for applications that are susceptible to oscillations. Thanks to the pilot piston's stroke-dependent damping system, oscillation-prone applications can be started in a very stable manner. The starting pressure peak is reduced because in the starting zone the valve responds quickly to the pilot signal.

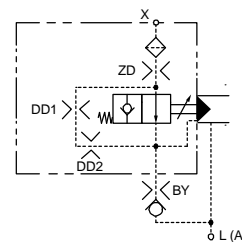

4.4.3 Stroke-dependent damping cover with metering grooves, type "K"

The stroke-dependent damping cover with metering grooves, type "K", is recommended for applications that are susceptible to oscillations, such as hydraulic motors (e.g. winches).

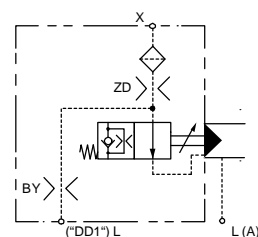

4.4.4 Hydromechanical stroke-limiting cover, type "H"

With the type "H" pilot control, the stroke of the load-control spool can be limited from outside the valve to achieve a particular flow rate or speed. This reduces the valve resolution.

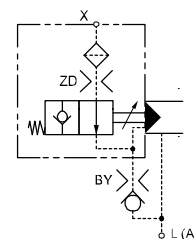

4.4.5 Hydraulic pressure-reducing valve cover type "R"

Pilot control type "R" denotes the version in which the incoming pilot pressure is reduced to a preset level. This function is needed when working with compensated and over-compensated applications, and the actual pilot pressure in the pilot chamber must not exceed 19 bar. The small leakage flow from the pressure reducing valve is discharged through an internal drain connection. The maximum allowable inlet pressure at port X is 100 bar. Because compensated and over-compensated systems must always be externally controlled, an inlet orifice is not normally required.



IMPORTANT!: Only available in return pressure independent version (L).

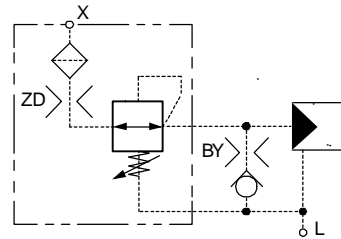

4.4.6 Electroproportional pressure-reducing valve cover type "E"

The type "E" control can be used for electroproportional control. In this case, the inlet signal at port X is reduced to a level proportional to the applied control current. The small flow of pilot oil from the pressure reducing valve is led away through an internal drain connection or a separate drain port. This control type is only intended for external pilot oil supplies, and it is essential to use a back-pressure-independent body (L).

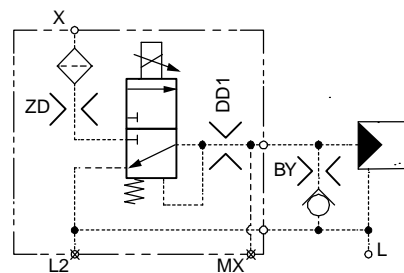

Hydraulic characteristics	Description, value, unit	
Pilot-oil supply at X	min. 30 bar max. 350 bar	[min. 435.11 psi] [max. 5076.32 psi] *
Permissible tank pressure at L (static)	max. 5 bar	[max. 72.51 psi]
Flow rate (pump) available at X	min. 2 l/min	[min. 0.528 gpm]
Pilot-oil consumption / Leakage flow rate	< 0.1 l/min (I = 0) < 0.5 l/min (I = max)	[< 0.026 gpm (I = 0)] [< 0.132 gpm (I = max)]
Hysteresis (with PWM control; pulse frequency 100 Hz)	0.5 bar	[7.25 psi]
Pilot-pressure control range	0...20 bar	[0...290.07 psi] *

* Other values on request

Electrical characteristics	Description, value, unit	
Nominal voltage	12 V DC	24 V DC
Resistance R 20	5.3 Ω ± 5 %	21.2 Ω ± 5 %
Maximum current at 100% duty cycle	1500 mA	750 mA
Power consumption at operating temperature (with increased resistance)	18 W	18 W
Control current at start of opening	~ 600 mA	~ 300 mA
Control current when fully open	~ 1400 mA	~ 700 mA
Relative duty cycle	100 %	
Insulation class	180 °C (VDE 0580:H)	[356 °F]
Protection class	IP 65 (DIN VDE 0470)	
Connector plug type	AMP Junior Timer Deutsch Plug DT04-2P	

 **IMPORTANT!** Only available in return pressure independent version (L).

General:

The series-connection of the orifices allows the opening time, the closing time, the start of opening, and the full extent of opening to be matched to the requirements of the application.

5 Performance graphs

measured with oil viscosity 33 mm²/s (cSt)

$\Delta p = f(Q)$ Pressure drop - Flow rate characteristic

Lifting A → B

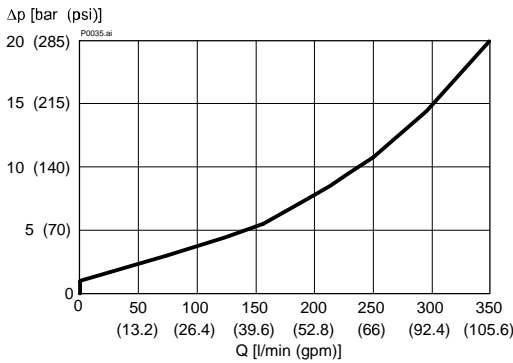

$\Delta p = f(Q)$ Pressure drop - Flow rate characteristic

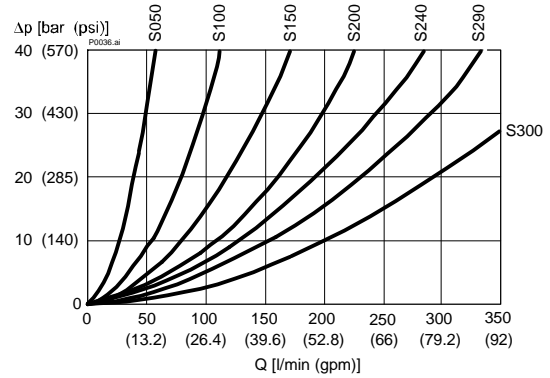

Lowering B → A

6 Available modules

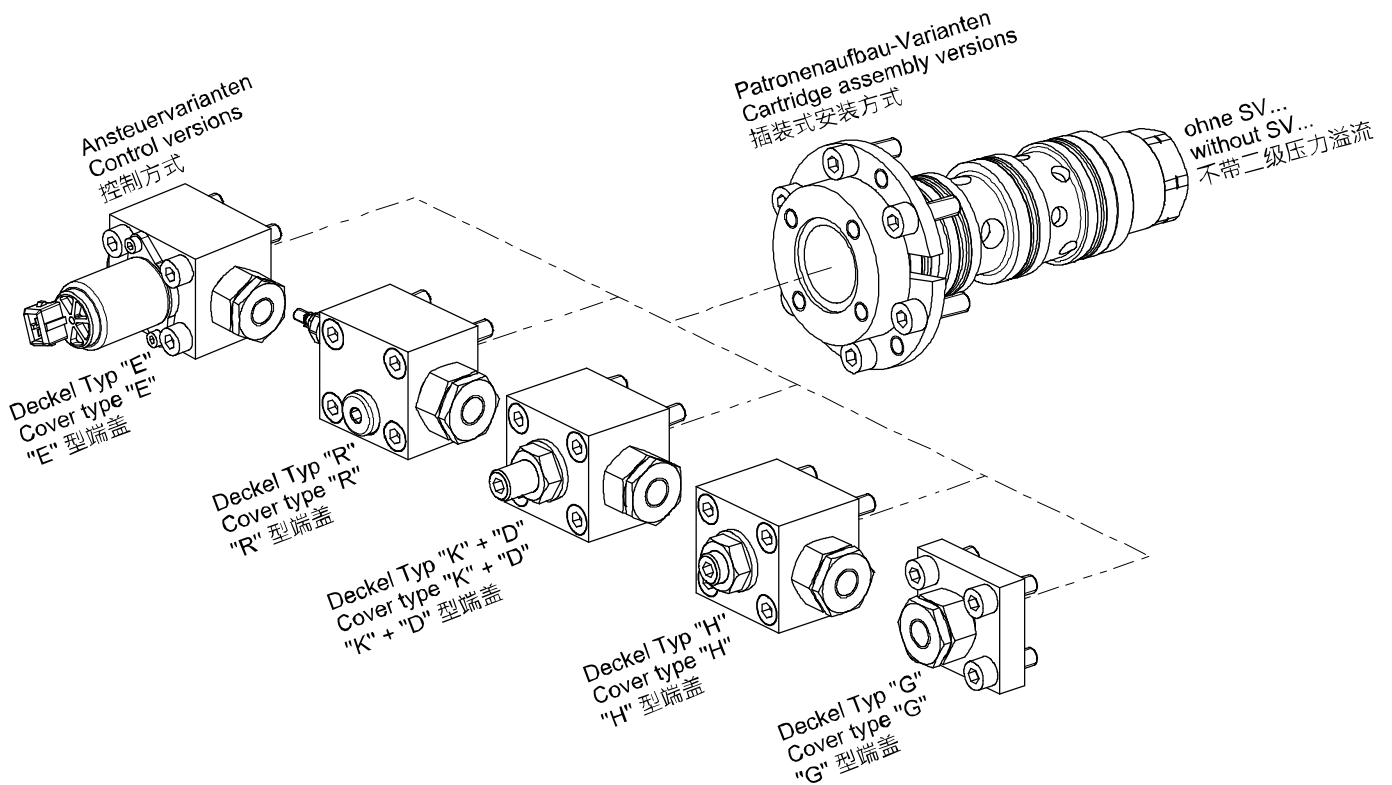

7 Dimensions & sectional view

Ohne Druckbegrenzungsventil
Without pressure relief valve
不带溢流阀

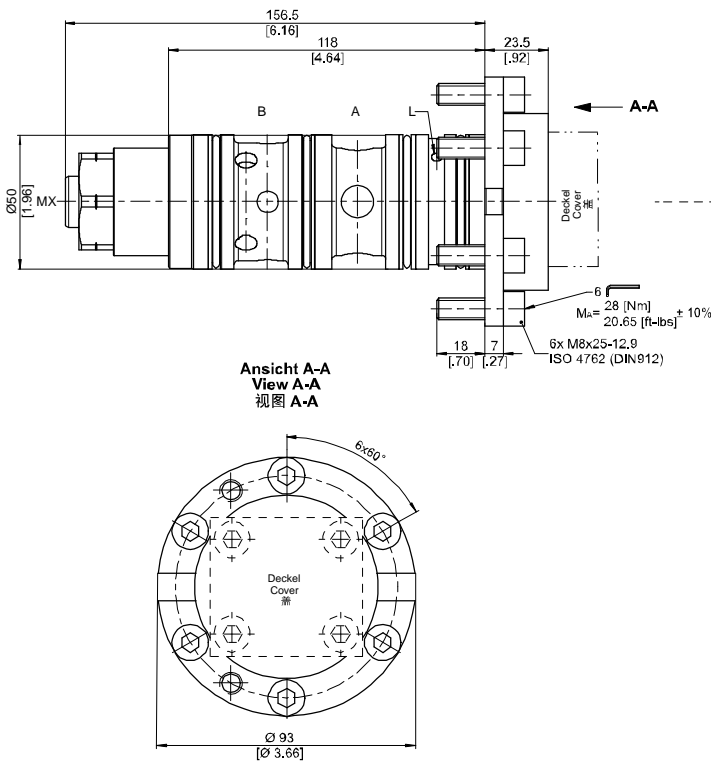

Standarddämpfungsdeckel Typ "G"
Standard damping cover type "G"
"G" 型标准阻尼功能端盖

Beispiel für die Masseinheit:
Example for the dimensional units:
尺寸单位举例:
0.79 = 0.79 mm millimeter
[.031] = 0.031 " inch

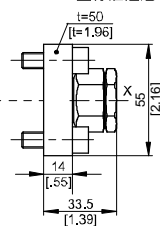

Hubabhängiger Dämpfungsdeckel Typ "D"
Hubabhängiger Kerbdämpfungsdeckel Typ "K"
Stroke-dependent damping cover type "D"
Stroke-dependent damping cover with metering grooves type "K"

"D" 行程相关阻尼功能端盖
"K" 行程相关阻尼功能端盖·带沟槽

* = werkseitige Einstellung
* = factory setting
* = 工厂设定

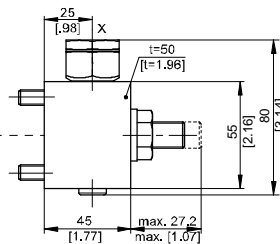

Hydromechanischer Hubbegrenzungsdeckel Typ "H"
Hydromechanical stroke-limiting cover type "H"
"H" 型机械-液行程限制功能端盖

* = werkseitige Einstellung
* = factory setting
* = 工厂设定

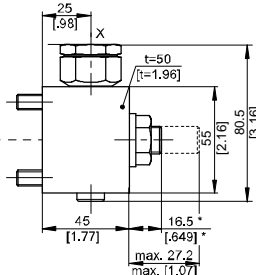

Hydraulischer Druckminderventildeckel Typ "R"
Hydraulic pressure-reducing valve cover type "R"
"R" 型减压阀功能端盖

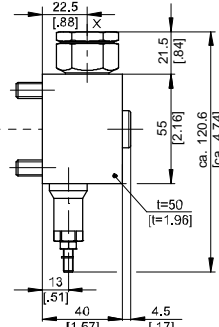

Elektronischer proportionaler Druckminderventildeckel Typ "E"
Electronic proportional pressure reducing valve cover type "E"
"E" 型电比例减压阀功能端盖

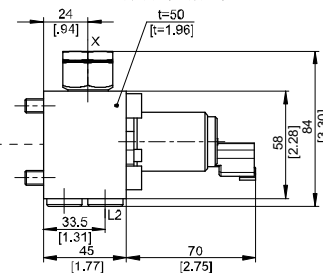

7.1 Cavity type

SCHNITT A-A
CUT A-A
剖面图A-A

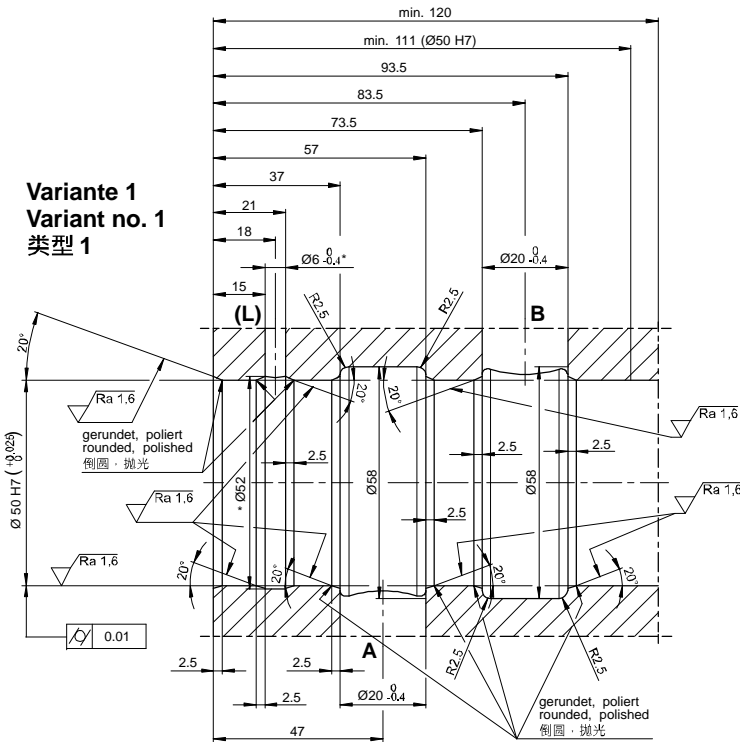

- * Anschluss L mit Einstich Ø52 kann bei Variante A (Rücklaufdruckabhängig) weggelassen werden.
- * Port L with Ø52 recess can be omitted for variant A (influenced by return-line pressure).
- * 对于型号A类型阀(受回油跨压影响)可以省略 Ø52 凹槽和油口L.

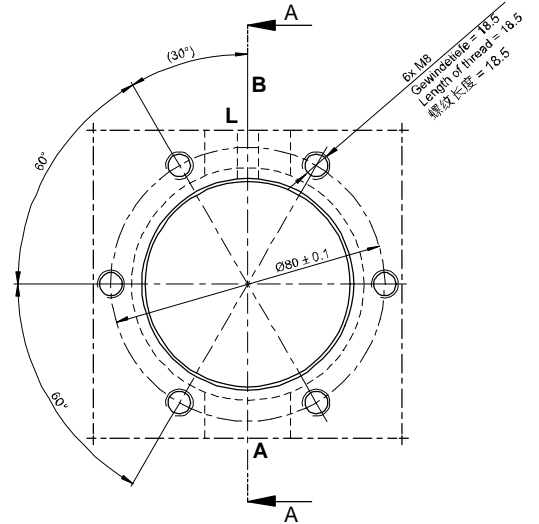

Variante 2
(übrige Masse – siehe Variante 1)
Variant no. 2
(all other dimensions – see variant no. 1)
类型 2
(其它所有尺寸 – 参见变量 1)

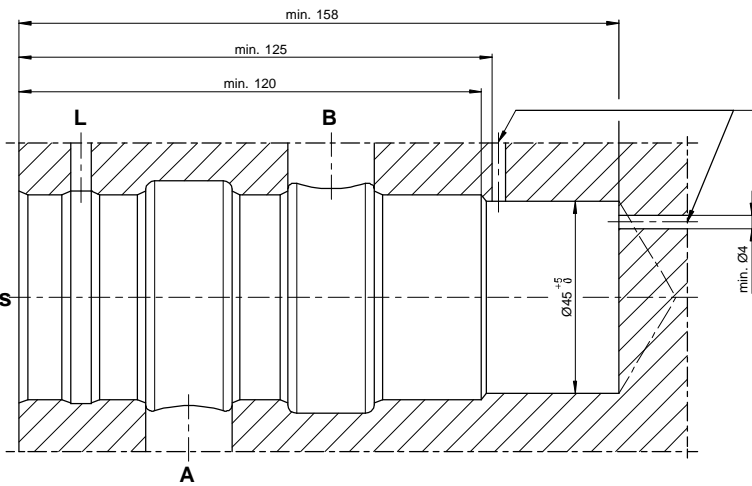

Die Bohrung $\text{Ø}45 \begin{smallmatrix} +5 \\ 0 \end{smallmatrix}$ muss mit einer Bohrung $\text{Ø}4$ (radial oder axial) drucklos mit Atmosphäre verbunden werden!
The hole $\text{Ø}45 \begin{smallmatrix} +5 \\ 0 \end{smallmatrix}$ must be connected to atmosphere by a hole of $\text{Ø}4$, either in axial or radial direction!
 $\text{Ø}45 \begin{smallmatrix} +5 \\ 0 \end{smallmatrix}$ 孔必须通过一个 $\text{Ø}4$ 的轴向(或径向)孔连接大气

Toleranzen nach:
Tolerances according to: DIN ISO 2768-mK
公差基于:

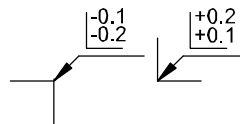
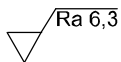

	∇ Ra 1,6	∇ Ra 6,3
Rauheitsklasse Roughness class 粗糙度等级	N7	N9
Rz [μm]	10	40

8 Safety instructions

IMPORTANT!
 Designing load-control valves requires specialist technical knowledge and product knowledge.
 Safety applications must be verified by adequate tests to ensure safety in actual use.

8.1 Assembly / disassembly

IMPORTANT!
 The valve may only be used for its intended purpose within its nominal rating. If you plan to use it outside the nominal rating, you must contact the valve manufacturer. The ultimate responsibility for safety in the installation and use rests with the end-machine manufacturer of the mobile application.

IMPORTANT!
 Seal kit with the external seals is available on application.

IMPORTANT!
 The port threads conform to DIN 3852 T1. Use screws to DIN 912, grade 12.9, to mount the valve.
 Tightening torques as per the manufacturer's instructions.

IMPORTANT!
 Protect seals and flange faces from damage. The mating flange face must be of the quality specified in the data sheet!
 Pay attention to the port designations.

9 Application examples

9.1 Cylinder application

CINDY 20-B-C with the control version type "G"

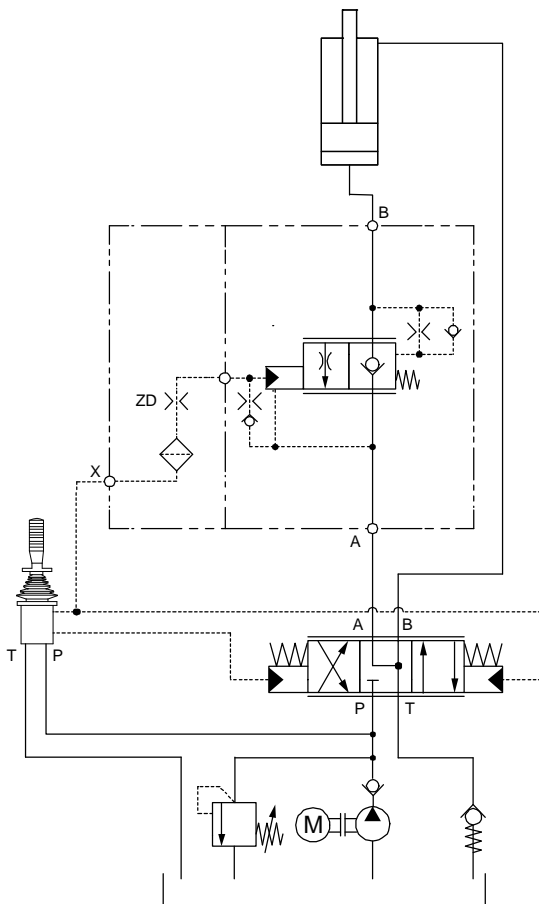

9.2 Motor application

CINDY 20-B-C with the control version type "K"

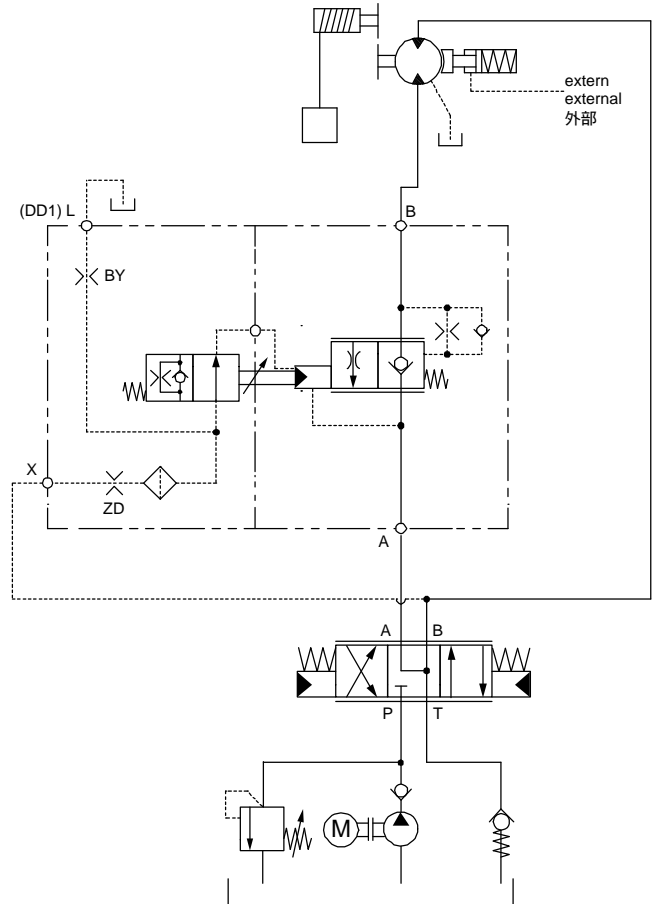

10 Ordering code

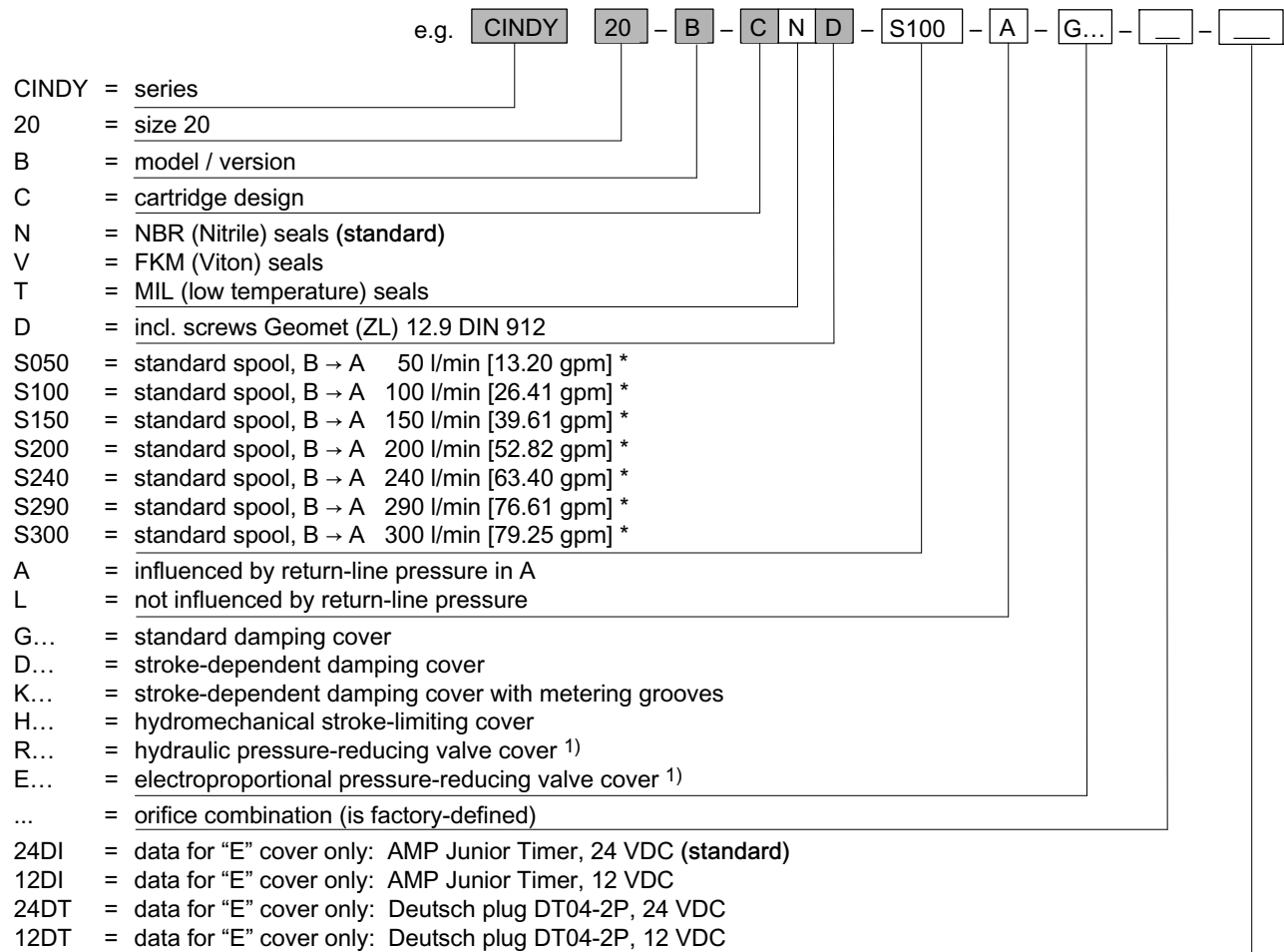

*) measured at 33 bar [478 psi] Δp from B → A.

¹⁾ Only available in return pressure independent version (L).

11 Related data sheets

Reference	Description
300-D-9050101	Technical design sheet for CINDY load-control valves in motor applications
300-D-9050102	Technical design sheet for CINDY load-control valves in cylinder applications



IMPORTANT!:

Additional documentation and 3D models (.stp or .igs format) can be downloaded from www.bucherhydraulics.com (LOGintern area; registration is necessary)

We also offer customised solutions. Please talk to our sales team.

info.ch@bucherhydraulics.com

www.bucherhydraulics.com

© 2019 by Bucher Hydraulics AG, CH-6345 Neuheim

All rights reserved.

Data is provided for the purpose of product description only, and must not be construed as warranted characteristics in the legal sense. The information does not relieve users from the duty of conducting their own evaluations and tests. Because the products are subject to continual improvement, we reserve the right to amend the product specifications contained in this catalogue.

Classification: 430.325.360.305.340.325.305.310