

3-WAY DIRECTIONAL CONTROL VALVE
SPOOL TYPE, PILOT OPERATED, SPOOL "F".

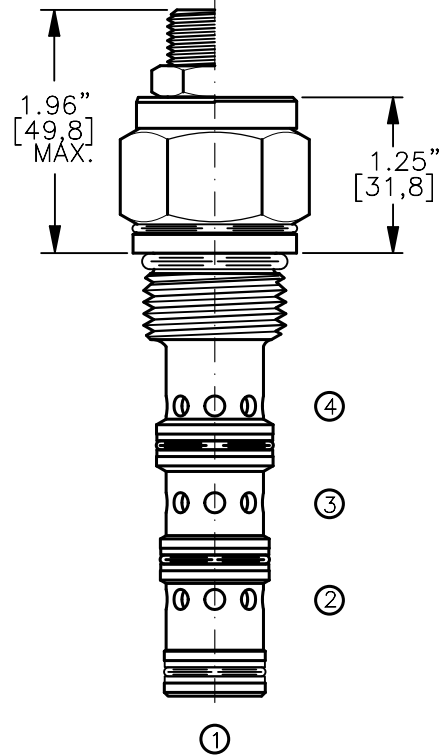
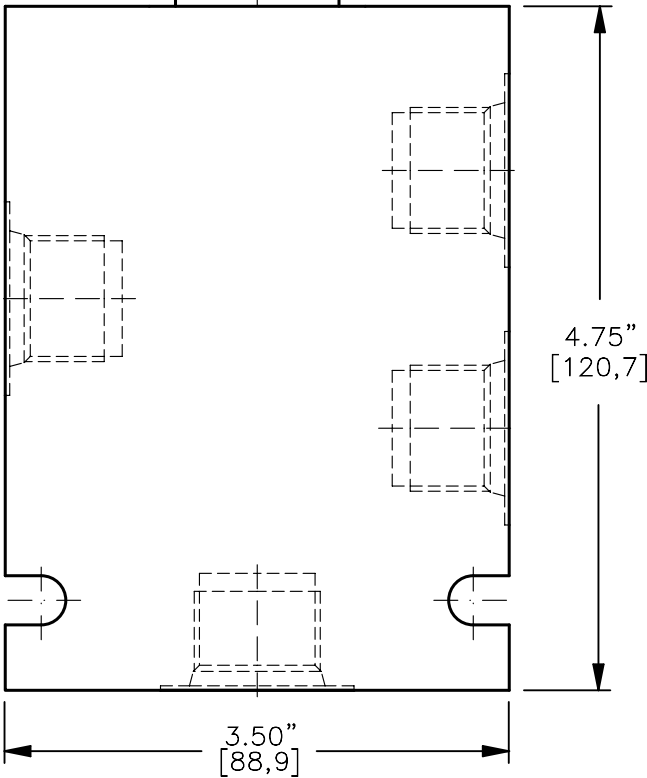
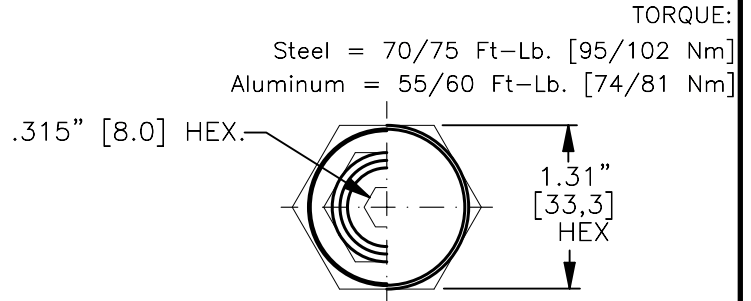
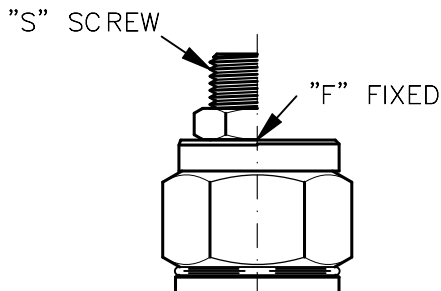
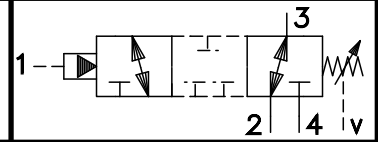

FOR ALUMINUM OR STEEL VALVE HOUSING CONFIGURATIONS SEE PAGE 0-043.1

DCPS-12-X-F-X-X-XXX

- BASIC
- SIZE
- 12 = 1.062-12 UNF
- SEALS
- N = BUNA "N"
- V = VITON
- SPOOL
- "F" = SPOOL
- ADJUSTMENT
- F = FIXED (FACTORY SET)
- S = ADJUSTING SCREW
- C = CAPPED
- T = TAMPERPROOF
- K = HANDKNOB
- M = METAL HANDKNOB

- PRESSURE BIAS SPRING
- 070 = 70 PSI (FIXED)
- 100 = 100 PSI (FIXED)
- 160 = 40-160 PSI (ADJ.)
- PORTS
- 0 = CARTRIDGE ONLY
- 04BX = G 1/2" BSPP
- 06BX = G 3/4" BSPP
- 10TX = SAE - #10
- 12TX = SAE - #12
- "A" - ALUM. HOUSING
- "S" - STEEL HOUSING

FOR ADJUSTMENT CONTROL
OPTIONS SEE PAGE 0-050.0

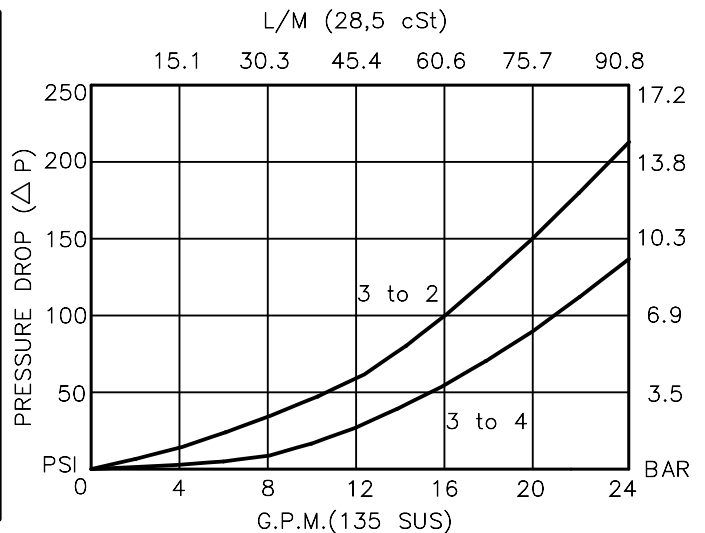

3-WAY DIRECTIONAL CONTROL VALVE SPOOL TYPE, PILOT OPERATED, SPOOL "F".

DESCRIPTION

This unit is a DIRECT ACTING, SCREW IN CARTRIDGE STYLE, SPOOL TYPE, HYDRAULIC 3-WAY DIRECTIONAL CONTROL ELEMENT, requiring remote pilot actuation.

OPERATIONS

This valve allows flow from port 3 to port 2 with a spring biased spool. Port 4 is blocked. The spool will shift when piloted at port 1 with sufficient pressure to overcome the spring bias and allow flow from port 3 to port 4. "V" spring chamber is vented to atmosphere. This valve shifts in a closed center position.

FEATURES AND BENEFITS

Leakproof screw adjustment.

This valve has a fixed or an adjustable bias spring.

Adjustment screw can not be backed out of the valve.

Overset protection – spring can not go solid.

Hardened precision fitted spool & cage provides reliable, long life.

A unibody cage construction provides very low hysteresis and reliable operation.

All external carbon steel parts are plated for longer life against the elements.

Valve is available with fixed, screw, tamperproof, capped and handknob adjustments.

All cartridge valves are 100% functionally tested.

Industry common cavity.

SPECIFICATIONS

OPERATING PRESSURE: 5,000 PSI [350 Bar]

PROOF PRESSURE: 10,000 PSI [700 Bar]

FLOW: 24.0 GPM [91 L/M] nominal. See performance chart.

INTERNAL LEAKAGE: 5 cu.in./min. [85 cc/m].

DEFINITION OF CRACK: evident at 0.06 GPM [0.25 LPM]

VALVE HOUSINGS: 2500 PSI [175 Bar] = Aluminum – Anodized.

5000 PSI [350 Bar] = Steel – Unplated.

OPERATING TEMPERATURE: -40° to +250° F. [-40° to +120° C.]

OPERATING MEDIA: All general purpose hydraulic fluids such as MIL-H-5606, SAE-#10, SAE-#20, etc.

INSTALLATION: No restriction.

FILTRATION: 25 microns or better.

SEAL KIT NUMBER: SKN-12462 for buna "N".

SKV-12462 for viton.

WEIGHT: 0.85 lb [.39 kg] cartridge only.

VALVE CAVITY: #C1240, See Page 0-043.0.

info.el@bucherhydraulics.com

www.bucherhydraulics.com/commoncavity

© 2015 by Bucher Hydraulics, Inc., 2545 Northwest Parkway, Elgin, Illinois 60124, USA

All rights reserved.

Data is provided for the purpose of product description only, and must not be construed as warranted characteristics in the legal sense. The information does not relieve users from the duty of conducting their own evaluations and tests. Because the products are subject to continual improvement, we reserve the right to amend the product specifications contained in this catalogue.