

Pressure-Relief Cartridge Valve, Size 10

$Q_{\max} = 100 \text{ l/min}$, $p_{\max} = 330 \text{ bar}$

Leak-proof shut-off, CE type-approved acc. Pressure Equipment Directive 2014/68/EU
 Series DDPSVA-1-10...

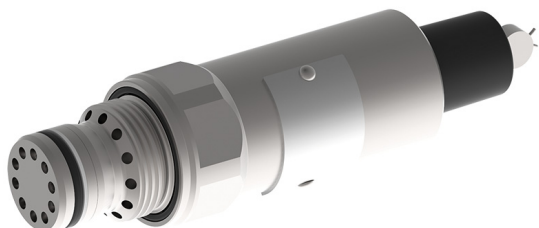

- Leak-proof shut-off from 1 → 2
- Extremely low leakage
- CE type-approved according Pressure Equipment Directive 2014/68/EU
- Security-sealed in the factory
- Compact design with M30x1.5 screw-in thread
- High flow rates
- All exposed parts with zinc-nickel plating

1 Description

Series DDPSVA-1-10 ... safety pressure-relief cartridges are size 10 valves with a M30x1.5 screw-in thread. They are direct acting with a seated design and feature extremely low leakage. These safety valves comply with the Pressure Equipment Directive 2014/68/EU and are set at the required response pressure and security-sealed. The preferred response pressures are 330, 315 and 100 bar and CE type-approved. Additional response pressures are available on application. These safety valves are typically used in hy-

draulic systems with pressure accumulators or pressure vessels. They safeguard the maximum allowable operating pressure by relieving oil from the protected line 1 to tank line 2. At Q_{\max} (100 l/min), the back pressure in the tank line must not exceed 3 bar. All external parts of the cartridge are zinc-nickel plated to DIN 50 979 and are thus suitable for use in the harshest operating environments. If you intend to manufacture your own cavities, please refer to chapter 6 "cavity".

2 Symbol

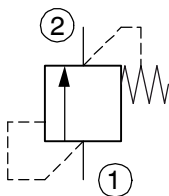

3 Technical data

General characteristics	Description, value, unit
Designation	pressure-relief cartridge valve
Design	leak-proof shut-off, CE type-approved according Pressure Equipment Directive 2014/68/EU
Mounting method	screw-in cartridge M30 x 1.5 – see chapter 6
Tightening torque	160 Nm \pm 5 %
Size	nominal size 10
Weight	0.66 kg
Mounting attitude	unrestricted
Ambient temperature range	-30 °C ... +70 °C

Hydraulic characteristics	Description, value, unit
Maximum operating pressure - port 2 - port 1	3 bar ¹⁾ 330 bar
Maximum flow rate	100 l/min
Response pressure	80 ... 330 bar
Flow direction	1 → 2, see symbols
Hydraulic fluid	HL and HLP mineral oil to DIN 51 524; for other fluids, please contact BUCHER
Hydraulic fluid temperature range	-25 °C ... +80 °C
Viscosity range	12...230 mm ² /s (cSt)
Minimum fluid cleanliness Cleanliness class to ISO 4406 : 1999	class 21/19/16



ATTENTION!

¹⁾ Any tank pressure acting at port 2 is additive to the pressure setting at the port 1.

4 Performance graphs

measured with oil viscosity 33 mm²/s (cSt)

$p = f(Q)$ Pressure - Flow rate characteristic

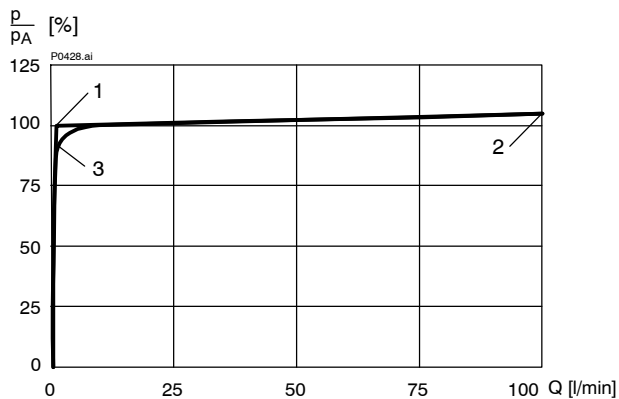

- 1.) Response pressure p_A
- 2.) Relieving pressure p_{ab} (maximum 10 % above p_A)
- 3.) Closing pressure p_s (maximum 15 % below p_A)

5 Dimensions & sectional view

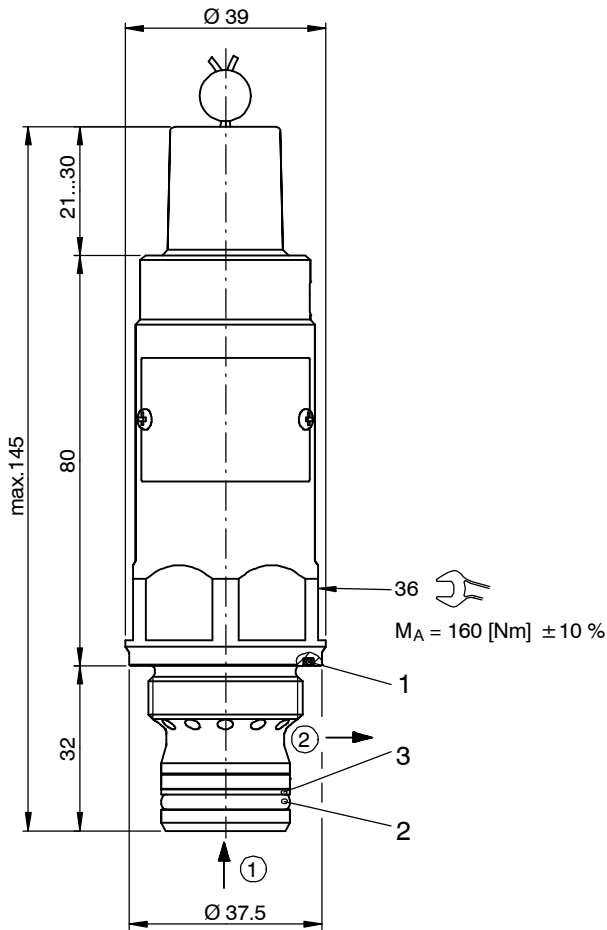

6 Cavity

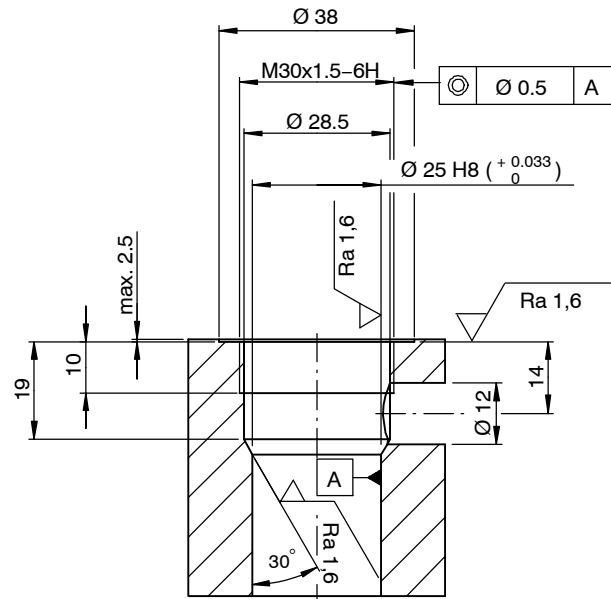

Cavity is manufactured with conventional tools (no form-tools available).



IMPORTANT!

We strongly recommend that pilot drilling, boring, reaming and cavity thread-cutting are performed in one setup.

7 Installation information



IMPORTANT!

When fitting the cartridges, use the specified tightening torque and refer to the instruction manual.



ATTENTION!

Only qualified personnel with mechanical skills may carry out any maintenance work. Generally, the only work that should ever be undertaken is to check, and possibly replace, the seals. When changing seals, oil or grease the new seals thoroughly before fitting them.



IMPORTANT!

These safety pressure-relief cartridges are security-sealed in the factory. If the sealing wire is damaged, the safety of the cartridges can no longer be guaranteed.

Seal kit NBR no. DS-478-N ²⁾

Item	Qty.	Description
1	1	O-ring no. 026 $\varnothing 31,47 \times 1,78$ N90
2	1	O-ring no. 117 $\varnothing 20,29 \times 2,62$ N90
3	1	Backup ring $\varnothing 19,90 \times 2,20 \times 1,00$ FI0751



IMPORTANT!

²⁾ Seal kit with FKM (Viton) seals, no. DS-478-V

8 Ordering code

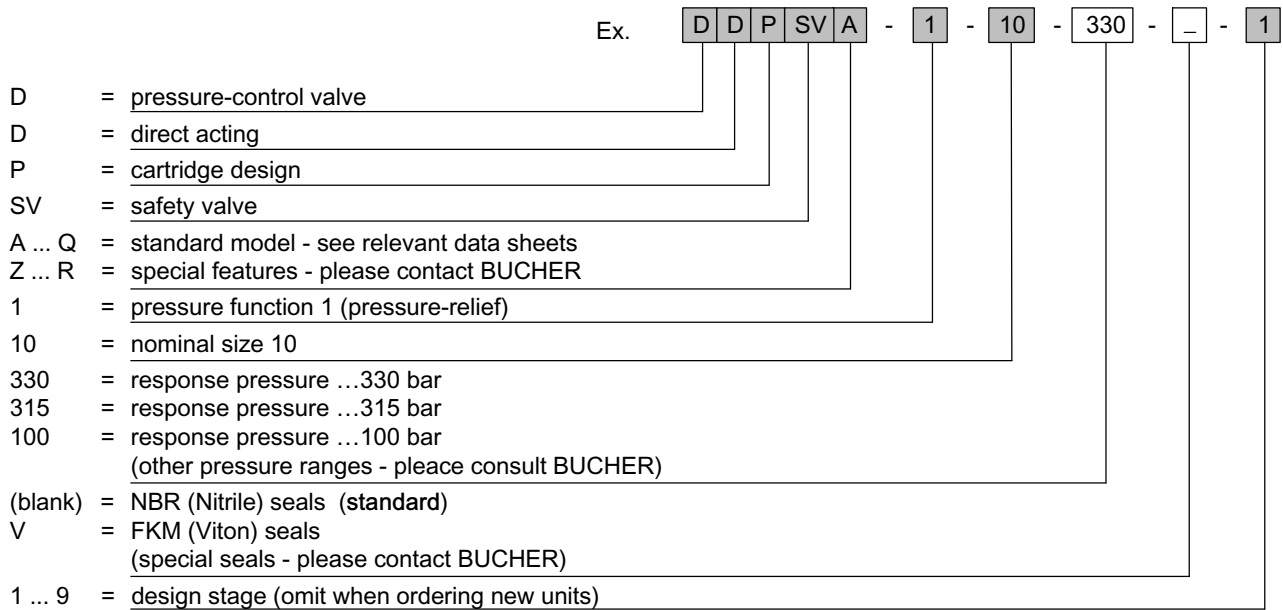

9 Related data sheets

Reference	(Old no.)	Description
400-B-900001		Instruction Manual, Safety Pressure-Relief Cartridge DDPSVA-1-10...
see Instruction Manual (400-B-900001)		Declaration of Conformity – on request
...		Certificate of conformity to notified body (according to module F) – on request

info.ch@bucherhydraulics.com

www.bucherhydraulics.com

© 2018 by Bucher Hydraulics AG Frutigen, CH-3714 Frutigen

All rights reserved.

Data is provided for the purpose of product description only, and must not be construed as warranted characteristics in the legal sense. The information does not relieve users from the duty of conducting their own evaluations and tests. Because the products are subject to continual improvement, we reserve the right to amend the product specifications contained in this catalogue.

Classification: 430.305.300.305.320.360