

2/2 ... 4/3 Solenoid Directional Seat Valve, ISO Size 03

$Q_{\max} = 20 \text{ l/min (5.3 gpm)}$, $p_{\max} = 315 \text{ bar (4500 psi)}$

Bidirectional leak-proof shutoff, direct acting, with EX-safty solenoid coil
Series EEX-W2N...

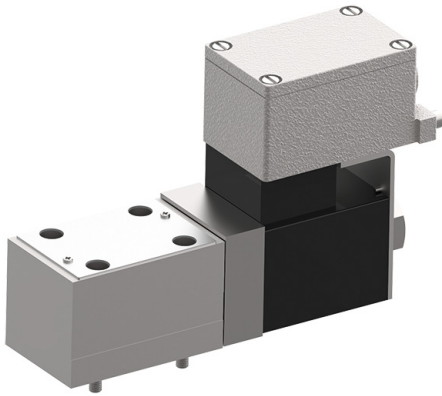

Valve:

- With cartridge valve, type EEX-W1.B...
- Interface to ISO 4401-03-02
- Bidirectional leak-proof shutoff or flow
- De-energised closed
- Guided valve spool and poppet
- Available in two mounting versions
- With or without manual override

Solenoid coil:

- To IEC/EN 60079-0, IEC/EN 60079-7, IEC/EN 60 079-18
- For equipment in Category 2 (Zones 1 and 2)
- Certificate of conformity: BASEEFA 02 ATEX 0199 X

 II 2 G Ex e mb IIC T4 Gb

1 Description

The EEX-W2N... series of 2/2 ... 4/3 solenoid operated directional seat valves are direct acting, pressure balanced, manifold-mounting valves with a size 03 interface to ISO 4401-03-02. An EX-protected solenoid for explosive gas atmospheres (II 2 G) is used to provide electrical operation of the cartridge. The main components of the valves are a manifold-mounting body and the push-in 2/2 or 3/2 directional seat valve cartridge (type EEX-W1.B...). Dependent on the operating position, the ports are either closed with virtually zero leakage, or open and flow is possible in either direction. These solenoid operated seat valves are also available with or without manual override lever. For applications where a check valve or an orifice in the P port is necessary, either of these features can be included as an option. They are suitable where leak-tight shut-off functions are crucially import-

ant. Examples are where loads, tensions, or clamping forces must be held without leakage. All external parts of the valve are corrosion-protected, and the valves are thus also suitable for use outdoors.

Ex: Solenoid conforms to the European standards IEC/EN 60079-0, IEC/EN 60079-7, IEC/EN 60079-18

e: Increased safety

mb: Encapsulation

Group IIC: For use in explosive gas atmospheres

T4: Max. surface temperature 135 °C

Gb: For use in Zone 1 (Zone 2) with foreseeable faults

Certificate of conformity:

BASEEFA 02 ATEX 0199 X

IECEx BAS13.0093 X (on request)

2 Technical data

General characteristics	Description, value, unit
Designation	2/2, 3/2, 3/3 or 4/3 solenoid operated directional seat valve
Design	manifold-mounting, bidirectional leak-proof shutoff, direct acting poppet and valve-spool design (pressure balanced) with EX-protected solenoid
Mounting method	4 x \varnothing 5.5 holes for M5x30 cap screws
Tightening torque	5.2 Nm \pm 10 % (4 ft-lbs \pm 10 %)
Size	size 03 interface to ISO 4401-03-02 / DIN 24 340 A6

General characteristics	Description, value, unit
Weight	2.3 kg (1 solenoid) 3.6 kg (2 solenoid)
Mounting attitude	unrestricted
Ambient temperature range	see hydraulic and electrical characteristics

Hydraulic characteristics	Description, value, unit
Maximum operating pressure	315 bar (4500 psi)
Maximum flow rate	20 l/min (5.3 gpm)
Flow direction	see symbols
Hydraulic fluid	HL and HLP mineral oil to DIN 51 524; for other fluids, please contact BUCHER
Ambient temperature range ¹⁾	-25 °C ... +80 °C (-13 °F ... +176 °F)
Hydraulic fluid temperature range ¹⁾	-25 °C ... +80 °C ²⁾ (-13 °F ... +176 °F) ²⁾
Viscosity range	10...500 mm ² /s (cSt), recommended 15...250 mm ² /s (cSt)
Minimum fluid cleanliness Cleanliness class to ISO 4406 : 1999	class 20/18/15

Electrical characteristics	Description, value, unit
Supply voltage	24 V DC 230 V AC <small>In AC solenoids, rectifier is integrated.</small>
Supply voltage tolerance	± 10 %
Ambient temperature range ¹⁾	-40 °C ... +40 °C (-40 °F ... 104 °F) (operation as T4)
Temperature class	T1 ... T4
EX-protection marking	II 2 G, Ex e mb IIC T4 Gb
Nominal power consumption	31,9 W at 20 °C (31.9 W at 68 °F)
Relative duty cycle	100 %
Protection class to ISO 20 653 / EN 60 529	IP 54 <small>(with properly fitted cable gland and properly made cable connection)</small>
Electrical connection	Shipped without cable gland (M20 x 1.5) and without cable <small>Cable-entry temperature may exceed 70 °C</small>



IMPORTANT!:

1) The less favourable values from the hydraulic and electrical characteristics determine the temperature range of the whole valve.



IMPORTANT!:

2) The maximum fluid temperature must not exceed the permissible ambient temperature for the whole valve.

3 Performance graphs



IMPORTANT!

Detailed performance data and other hydraulic characteristics can be found in the data sheet for the respective 2/2 or 3/2 solenoid operated cartridge seat valve (series EEX-W1.B...) that is fitted. See "Related data sheets".



ATTENTION!

The performance figures in the data sheet for the cartridge valve refer just to the cartridge itself. Take into account the additional pressure drop in the body into which it is fitted.

$\Delta p = f(Q)$ Pressure drop - Flow rate characteristic through orifice (metering function)

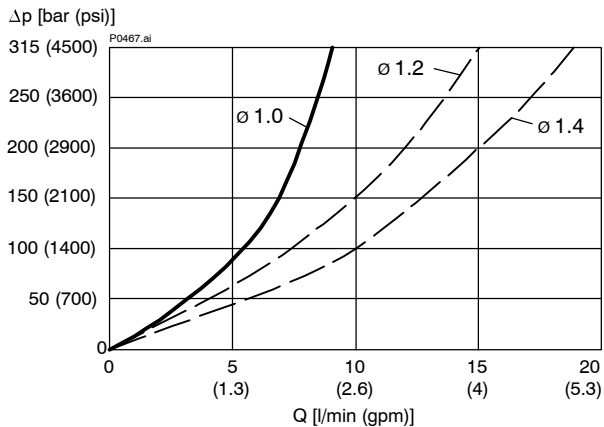

$\varnothing 1.2$ and $\varnothing 1.4$ orifices drilled out by customer!

$\Delta p = f(Q)$ Pressure drop - Flow rate characteristic through push-in check valve

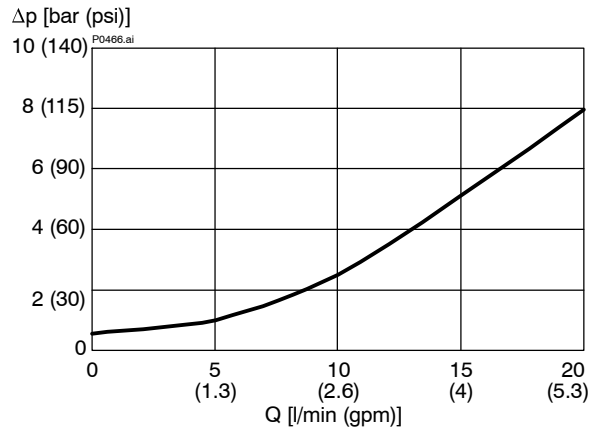

Code	Symbols	Remarks	Operating principle
2-way circuit (with 2/2 cartridge seat valve)		For 2/2 circuits, the customer must plug the T port!	
		For 2/2 circuits, the customer must plug the P port!	
3-way circuit (with 3/2 cartridge seat valve)		For 2/2 circuits, the customer must plug the T port!	
		For 2/2 circuits, the customer must plug the T port!	
3-way circuit (with 2/2 cartridges)		Unacceptable heating-up Energising solenoids a and b simultaneously is not permitted!	
4-way circuit (with 3/2 cartridge seat valves)		Unacceptable heating-up Energising solenoids a and b simultaneously is not permitted!	
		Unacceptable heating-up Energising solenoids a and b simultaneously is not permitted!	
		Unacceptable heating-up Energising solenoids a and b simultaneously is not permitted!	

4 Dimensions & sectional view

2/2 and 3/2 solenoid operated directional seat valve (single-solenoid model)

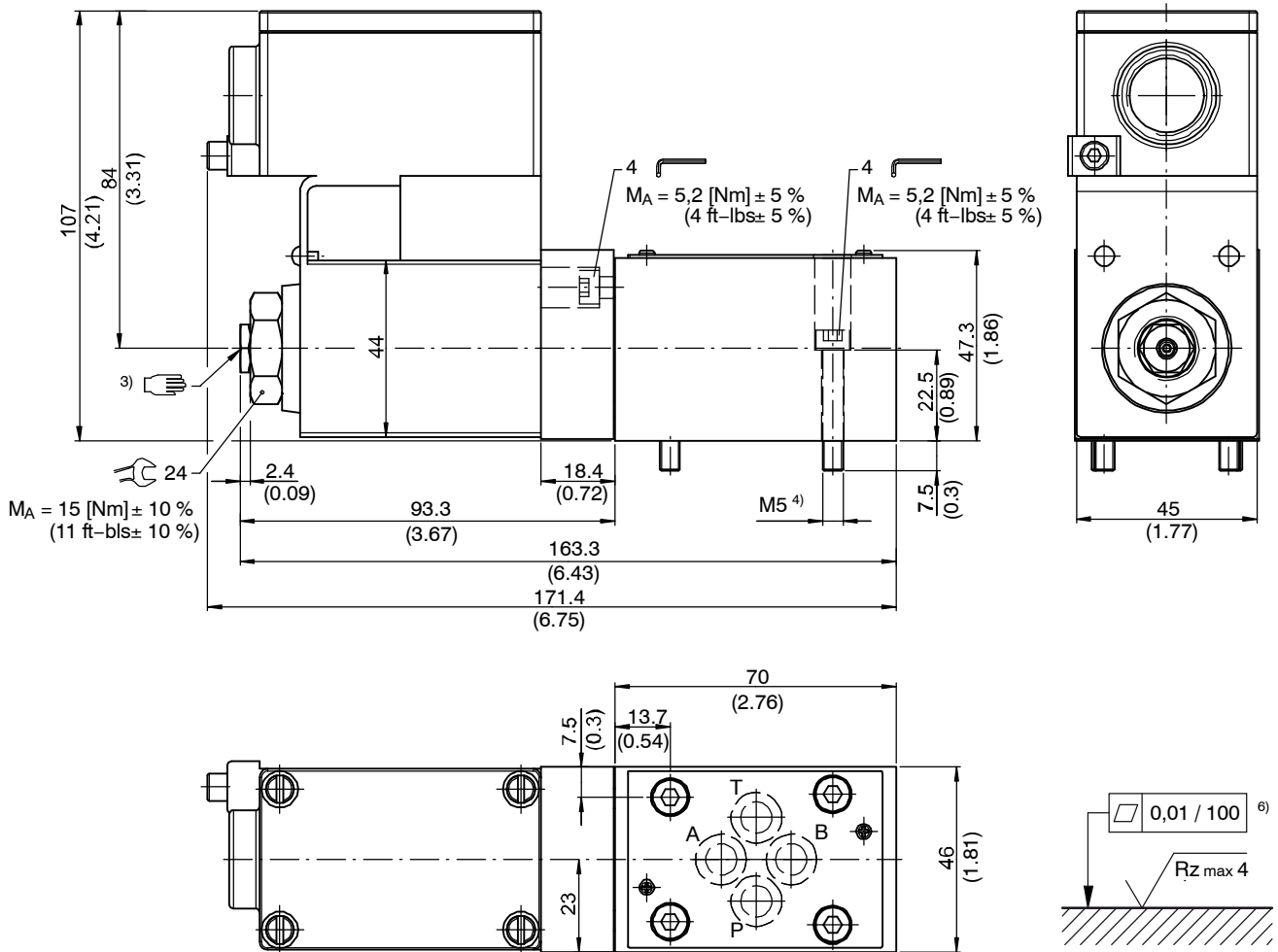

3/3 and 4/3 solenoid operated directional seat valve (double-solenoid model)

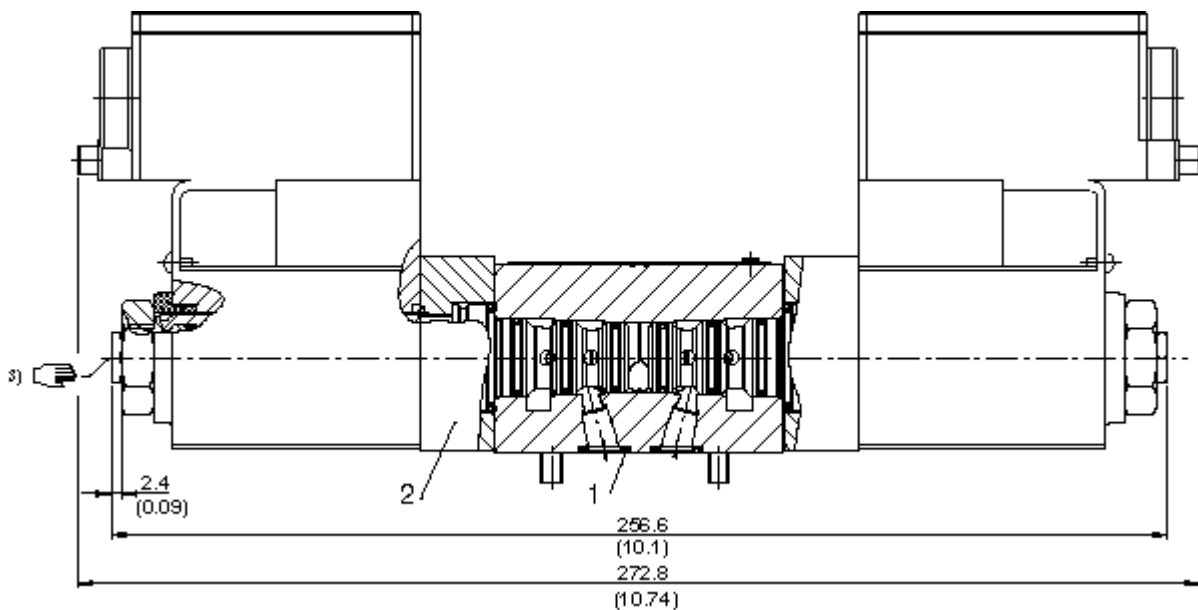

Seal kit no. DS-475-N ⁵⁾

Item	Qty.	Description
1	4	O-ring no. 012 \varnothing 9,25 x 1,78 N90
2	2	NBR seal kit no. DS-263-N for seat valve, type EEX-W1...

4.1 Push-in check valve

To prevent uncontrolled back-pressure effects or back-flow of oil, series EEX-W2N... solenoid operated directional seat valves can be supplied with an optional push-in check valve, type RCA-5, and a special body. The check valve allows free flow from P to A or B, but prevents flow in the opposite direction, with no leakage.

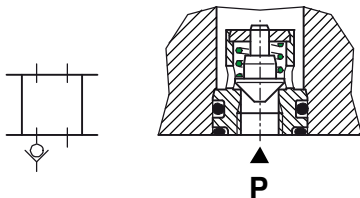

Application: when several valves are supplied in parallel, for instance, and the supply pressure in P drops below the pressure in A or B (another circuit is vented, or a lightly-loaded actuator is operated). The pressure in service line A or B is then higher, but the check valve prevents it from falling during such operations in other circuits.

5 Installation information

COMMISSIONING

- For short-circuit protection, each solenoid must be preceded by a fuse conforming to B588 or IEC269 with a maximum rating of 2 A (AC) or 6 A (DC).
- The solenoid coils must only be operated when they are fitted on the associated valve. For more information on installation and commissioning, please refer to the operating instructions supplied with the solenoid coil.



ATTENTION!

Ratings given in the operating instructions. Pay attention to the relevant operating instructions! If in doubt, the ratings in the operating instructions apply.



ATTENTION!

Only qualified personnel with mechanical skills may carry out any maintenance work. Generally, the only work that should ever be undertaken is to check, and possibly replace, the seals. When changing seals, oil or grease the new seals thoroughly before fitting them.



IMPORTANT!

- 3) Can be chosen with or without manual override. (see ordering code)
- 4) Valve mounting bolts M5x30 (included in the delivery)
- 5) Seal kit with Viton seals, no. DS-475-V
- 6) Required surface finish on the mounting face (valve pad)

4.2 Orifice (metering function)

An orifice disc (type D10, \varnothing 1.0 mm) must be used when, as a consequence of the operating conditions that exist, circuit operations may result in flow rates that exceed the performance limit of the valve.



IMPORTANT!

The orifice disc fitted for this purpose is \varnothing 1.0 mm. Customers may drill it out to \varnothing 1.4 mm maximum (see performance graphs).

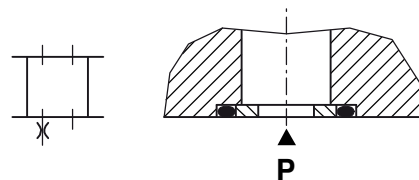

Application: when used for charging accumulators, for instance, or when the solenoid operated directional seat valves are used to pilot other valves.



ATTENTION!

Authorised persons
The tasks described here may only be carried out by authorised personnel. Authorised personnel are those who have electro-technical training (EN 60204-1).



IMPORTANT!

When fitting the cartridges, use the specified tightening torque for the mounting bolts. The marking "Valve End" on the adapter sleeve must be mounted towards the valve flange! No adjustments are necessary, since the cartridges are set in the factory.



IMPORTANT!

Minimum dimensions of the mating body
101 x 46 x 43 mm
See also the user manual.

6 Ordering code

	Ex.	EEx	W2	N	32S	N	6	B	B	24	
EEX	=	EX-protected coil instead of standard solenoid coil (for details, see electrical characteristics)									
W2	=	solenoid directional seat valve, manifold mtg.									
N	=	open crossover									
22 S	=	2/2 function, P closed									
22 O	=	2/2 function, P ↔ A connected									
32 S	=	3/2 function, P closed									
32 O	=	3/2 function, P ↔ A connected									
33 R	=	3/3 function, P, A and T closed									
43 F	=	4/3 function, P ↔ A ↔ B connected									
43 G	=	4/3 function, A ↔ B ↔ T connected									
N	=	without push-in check valve or orifice (standard)									
R	=	with push-in check valve, type RCA-5 (in P port)									
D10	=	with orifice disc, type D10 (in P port)									
6	=	ISO size 03 interface									
B ... Q	=	standard model - see relevant data sheets									
Z ... R	=	special features - please consult BUCHER									
Nitrile seals											
Viton seals											
B G	=	with manual override									
D I	=	without manual override									
1 ... 9	=	design number, seat valve (omit when ordering new units)									
...	=	voltage e.g. 24 (24 V)									
D	=	current DC									
A	=	current AC									

7 Related data sheets

Reference	(Old no.)	Description
400-P-030501	(i-31)	Size 03 interface to ISO 4401-03-02
400-P-110210		2/2 solenoid cartridge valve, type EEX-W1C... size 6
400-P-115115		3/2 solenoid cartridge valve, type EEX-W1D... size 6
D14-2117D		Operating instructions for solenoid coil DC LISK
K14-2068D		Operating instructions for solenoid coil AC LISK
D14-2130D3		Operating instructions for solenoid coil DC LISK IEC (on request)
D14-2078D3		Operating instructions for solenoid coil AC LISK IEC (on request)

info.ch@bucherhydraulics.com

www.bucherhydraulics.com

© 2018 by Bucher Hydraulics AG Frutigen, CH-3714 Frutigen

All rights reserved.

Data is provided for the purpose of product description only, and must not be construed as warranted characteristics in the legal sense. The information does not relieve users from the duty of conducting their own evaluations and tests. Because the products are subject to continual improvement, we reserve the right to amend the product specifications contained in this catalogue.

Classification: 430.300.-.315.315.300 (W-2.23)