

4/2 and 4/3 Solenoid Directional Valve, ISO Size 05

$Q_{max} = 90 \text{ l/min}$, $p_{max} = 315 \text{ bar}$

Two-stage design, with EX-safty solenoid coil
 Series EEXD-WEV...



Valve:

- High switching reliability thanks to two-stage follower spool design
- Slip-on coil design, coils can be changed without opening hydraulic envelope
- With manual override
- Interface to ISO 4401-05-04

Solenoid coil:

- To EN 60079-0, EN 60079-1, EN 60079-31
- Certificate of conformity:
BVS 14 ATEX E011

gas: Ex II 2 G Ex db IIC

dust: Ex II 2 D Ex tb IIIC

1 Description

Series EEXD-WEV...-10 high performance spool valves are two-stage units which use the follower spool principle. The main valve components are a steel body, a spring-centered follower spool assembly and wet armature solenoids with pressure-tight core tube and a slip-on coil which is certified for use in explosion-hazard areas. The coil slips over the core tube and is retained by a knurled nut. The solenoid housing is made of cast iron with spray painted finish. The solenoid armature is of the oil-immersed type. The solenoid housing is threaded M20 x 1,5 for a cable entry gland. The cable entry gland (which also must be certified to IEC/EN 60079-1) is not supplied with the valve and, if required, must be ordered as a separate item: Cable entry gland type AGRO 1820. 16.26 M20 x 1,5 (for cable $\varnothing 11...13$). The valves provide reliable service even under the severest operating conditions such as high flow rates,

high operating pressures, long periods without switching and large temperature fluctuations. The highly effective spool actuation method combines the advantages of both direct acting and two-stage solenoid valves, without incurring the well known disadvantages of either type. The main spool is offset by both the solenoid force and the P - T *) pressure difference inside the valve. The greater the P - T pressure difference, the greater the offsetting force. It is brought back to its deenergised position in the same way, using the P - T pressure difference and without the need for heavy centering springs.

*) The pressure in P must exceed that in T and the valve must be connected in the conventional manner i.e. pressure to P, T to tank.

Certificate of conformity:
BVS 14 ATEX E011

2 Technical data

General characteristics	Description, value, unit
Designation	4/2 and 4/3 solenoid directional valve
Design	manifold-mounting, two-stage
Mounting method	4 x $\varnothing 5,5$ holes for M6x60 cap screws
Tightening torque	9 Nm $\pm 10 \%$
Size	size 05 interface to ISO 4401-05-04 / DIN 24 340 A10
Weight	5.1 kg (1 solenoid) 7.1 kg (2 solenoid)
Mounting attitude	horizontal recommended (vertical mounting makes air bleeding difficult)
Ambient temperature range	see hydraulic and electrical characteristics

Reference: 400-P-191210-EN-02

Hydraulic characteristics		Description, value, unit
Maximum operating pressure	port A, B and P port T	315 bar 15 bar
Maximum flow rate		90 l/min
Flow direction		see symbols
Hydraulic fluid		HL and HLP mineral oil to DIN 51 524; for other fluids, please contact BUCHER
Ambient temperature range ¹⁾		-25 °C ... +80 °C
Hydraulic fluid temperature range ¹⁾		-25 °C ... +80 °C ²⁾
Viscosity range		10...500 mm ² /s (cSt), recommended 15...250 mm ² /s (cSt)
Minimum fluid cleanliness Cleanliness class to ISO 4406 : 1999		class 20/18/15
Electrical characteristics		Description, value, unit
Supply voltage		24 V DC 115 / 230 V AC 50 ... 60 Hz <small>In AC solenoids, rectifier is integrated.</small>
Supply voltage tolerance		+ 10 % / - 5 %
Ambient temperature range ¹⁾		-50 °C ... +90 °C (operation as T4 / T130 °C) -50 °C ... +55 °C (operation as T5 / T95 °C) -50 °C ... +40 °C (operation as T6 / T80 °C)
Temperature class		T1 ... T6
EX-protection marking	Gas: Dust:	II 2 G, Ex db IIC (T6, T5 or T4) II 2 D, Ex tb IIIC (T80 °C, T95 °C or T130 °C)
Nominal power consumption		V DC = 7 W V AC = 12 W
Relative duty cycle		100 %
Protection class to ISO 20 653 / EN 60 529		IP 65 <small>(with properly fitted cable gland and properly made cable connection)</small>
Electrical connection		shipped without cable gland (M20 x 1.5) and without cable <small>Cable-entry temperature may exceed 70 °C</small>



IMPORTANT!:





¹⁾ The less favourable values from the hydraulic and electrical characteristics determine the temperature range of the whole valve.

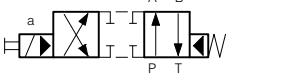
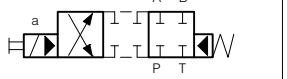
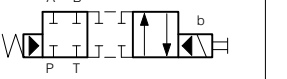
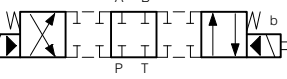
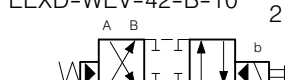
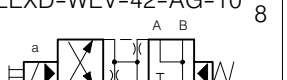
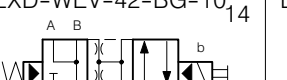
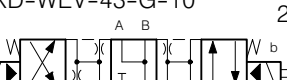

IMPORTANT!:

²⁾ The maximum fluid temperature must not exceed the permissible ambient temperature for the whole valve.

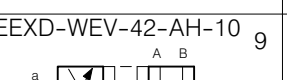

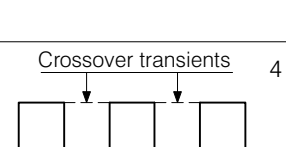
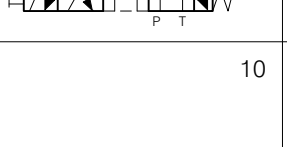
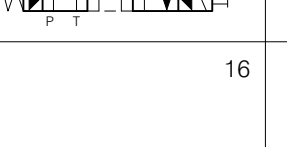

3 Symbol

4/2 FUNCTIONS	4/2 FUNCTIONS WITH 4/3 SPOOLS	4/2 FUNCTIONS WITH 4/3 SPOOLS	4/3 FUNCTIONS
EEXD-WEV-42-A-10  1	EEXD-WEV-42-AD-10  7	EEXD-WEV-42-BD-10  13	EEXD-WEV-43-D-10  19
EEXD-WEV-42-B-10  2	EEXD-WEV-42-AG-10  8	EEXD-WEV-42-BG-10  14	EEXD-WEV-43-G-10  20
 3	EEXD-WEV-42-AH-10  9	EEXD-WEV-42-BH-10  15	EEXD-WEV-43-H-10  21
Crossover transients  4	 10	 16	For other spools please consult BUCHER 22

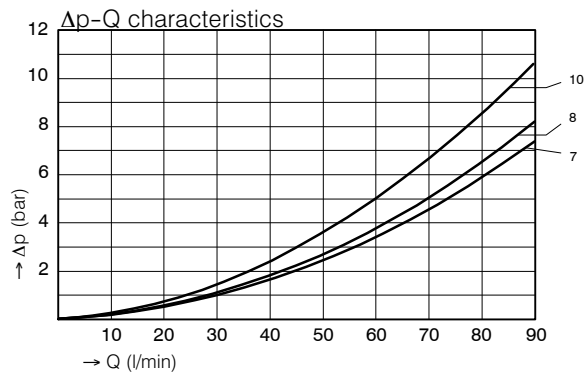
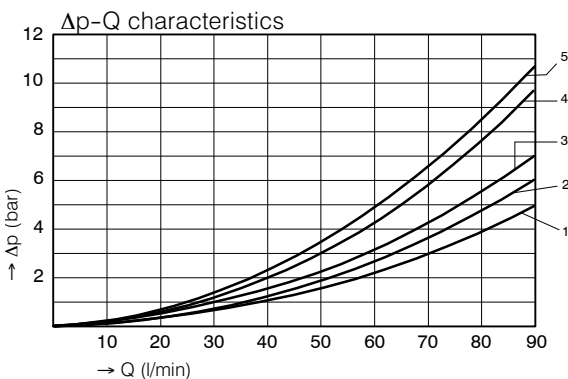
4 Performance graphs

measured with oil viscosity 33 mm²/s (cSt), coil at steady-state temperature and 5 % undervoltage



	energised				deenergised
	P ⇒ A	B ⇒ T	P ⇒ B	A ⇒ T	P + A+B ⇒ T
 A spool	2	5	2	5	--
 D spool	7	10	7	8	--
 G spool	3	4	3	2	--
 H spool	2	4	2	2	1

Switching times	Spool A, D, G	Spool H
Solenoid ON	100 ms	200 ms
Solenoid OFF	40 ms	40 ms

These are guideline values only, and can be significantly affected by flow rate, pressure and oil viscosity.

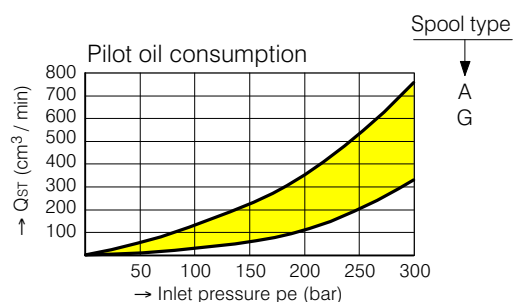
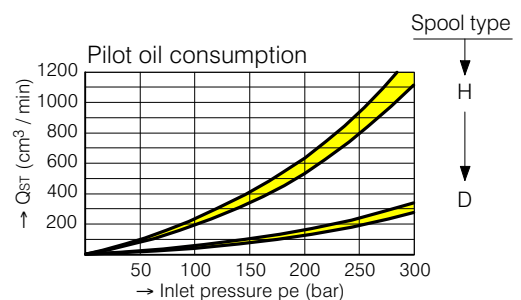

5 Installation information

COMMISSIONING

- For short-circuit protection, each solenoid must be preceded by a fuse conforming to IEC 60127 with a maximum rating of three times the rated current of the solenoid coil.
- The solenoid coils must only be operated when they are fitted on the associated valve. For more information on installation and commissioning, please refer to the operating instructions supplied with the solenoid coil.



ATTENTION!

Ratings given in the operating instructions

Pay attention to the relevant operating instructions! If in doubt, the ratings in the operating instructions apply.



ATTENTION!

Only qualified personnel with mechanical skills may carry out any maintenance work. Generally, the only work that should ever be undertaken is to check, and possibly replace, the seals. When changing seals, oil or grease the new seals thoroughly before fitting them.



ATTENTION!

Authorised persons

The tasks described here may only be carried out by authorised personnel. Authorised personnel are those who have electro-technical training (EN 60204-1).



IMPORTANT!

When fitting the cartridges, use the specified tightening torque for the mounting bolts. No adjustments are necessary, since the cartridges are set in the factory.

6 Dimensions & sectional view

The valve is supplied without cable or cable entry gland. If required, the cable entry gland must be ordered as a separate item. Pressure die cast cable entry gland type AGRO 1820.16.26 M20 x 1.5 (see also schematic section)

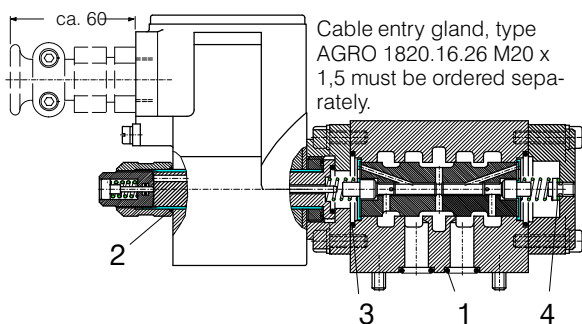
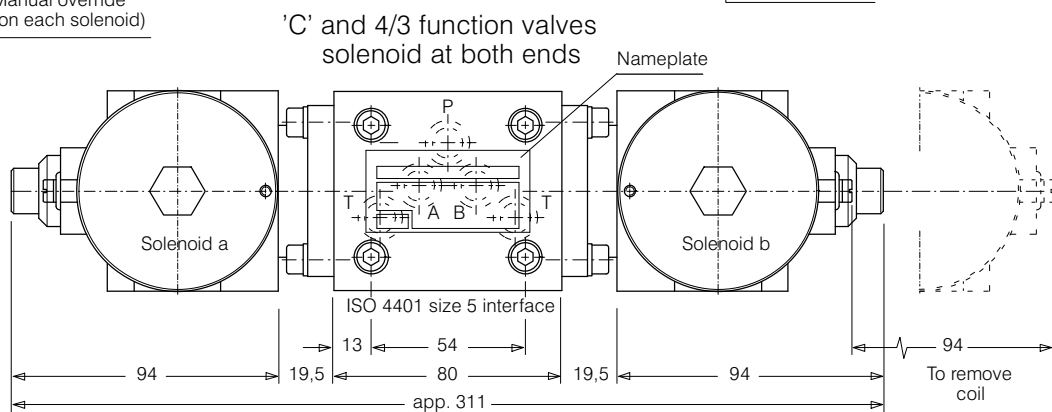
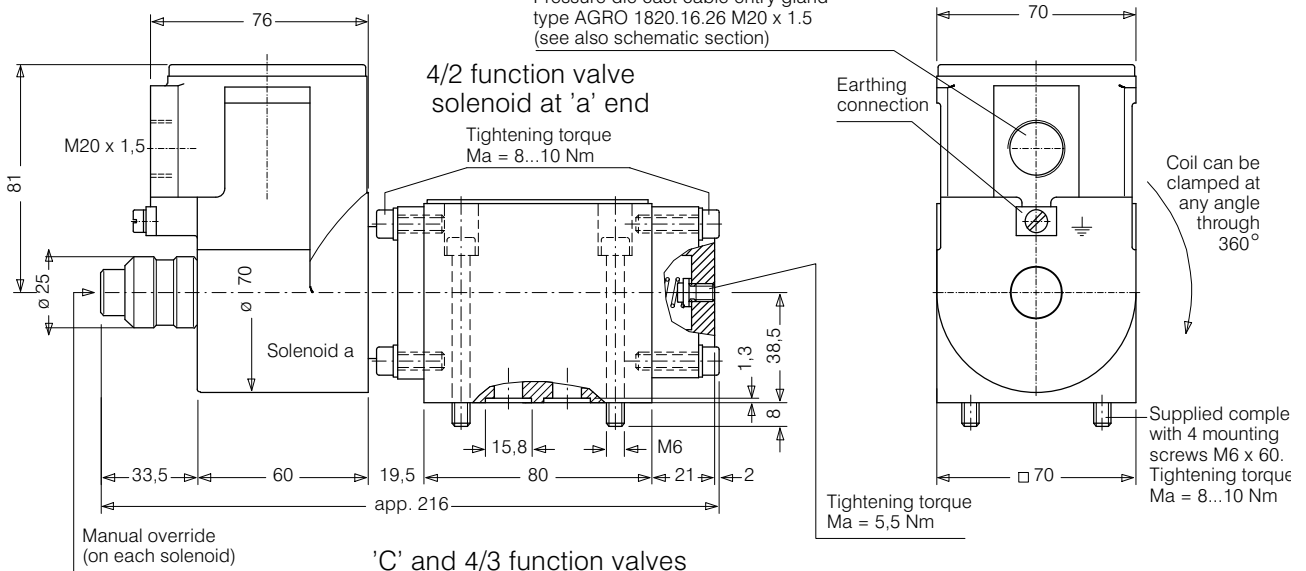

Seal kit no. DS-092-N ³⁾

Item	Qty. 4)	Qty. 5)	Description
1	5	5	O-ring no. 014 \varnothing 12,42 x 1,78 N90
2	1	2	O-ring no. 017 \varnothing 17,17 x 1,78 N90
3	2	2	O-ring no. 123 \varnothing 29,82 x 2,62 N90
4	1	-	Copper ring DIN7603A 6 / 10 x 1



IMPORTANT!

- 3) Seal kit with Viton seals, no. DS-092-V
- 4) 4/2 valves (1 solenoid)
- 5) 4/3 valves (2 solenoids)

7 Ordering code

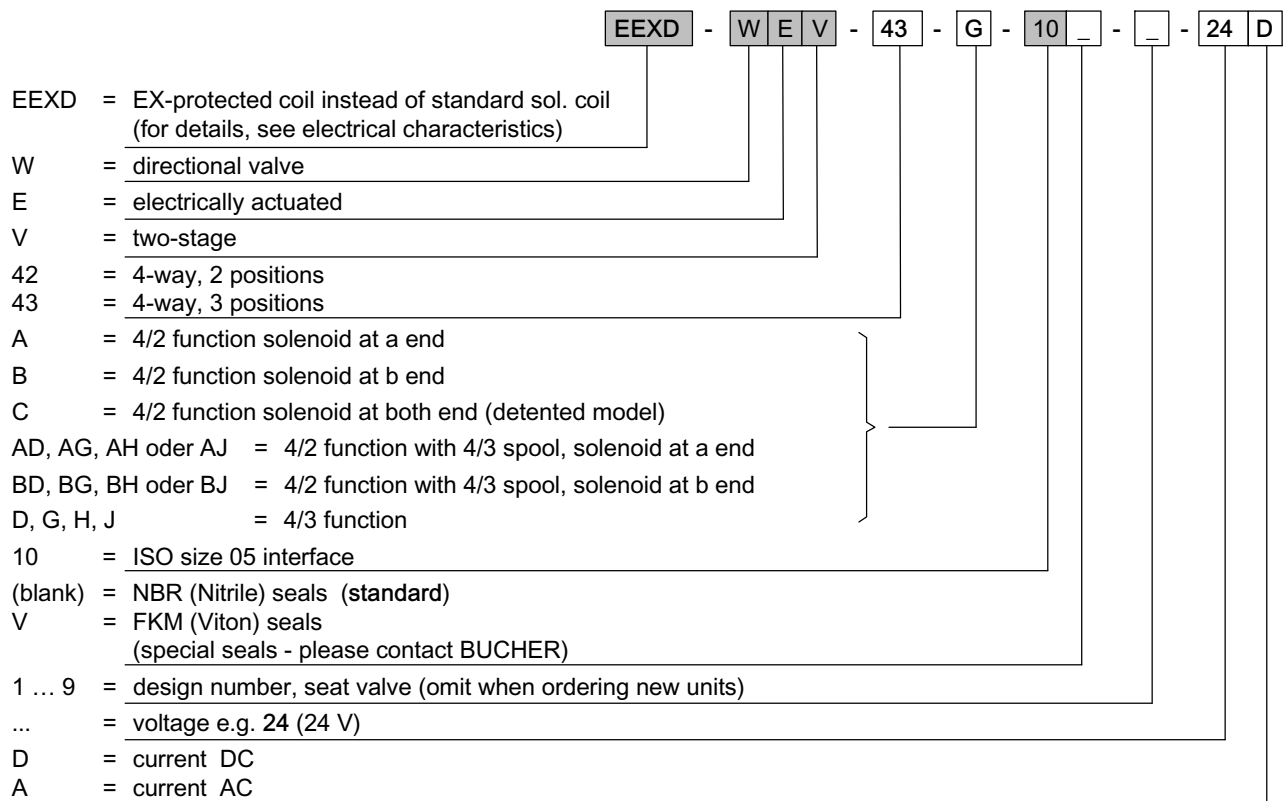

8 Related data sheets

Reference	(Old no.)	Description
400-P-050101	(i-41)	Size 05 interface to ISO 4401-05-04
...		Operating instructions for solenoid coil 2A6x, 2C6x, 2E6x, 2F6x (Seitz)

info.ch@bucherhydraulics.com

www.bucherhydraulics.com

© 2016 by Bucher Hydraulics AG Frutigen, CH-3714 Frutigen

All rights reserved.

Data is provided for the purpose of product description only, and must not be construed as warranted characteristics in the legal sense. The information does not relieve users from the duty of conducting their own evaluations and tests. Because the products are subject to continual improvement, we reserve the right to amend the product specifications contained in this catalogue.

Classification: 430.300.-.305.310.300