

Stacking Throttle / Check Valve, 10 mm

$Q_{max} = 160 \text{ l/min}$, $p_{max} = 350 \text{ bar}$

Series SRDB...

- Meter-in or Meter-out by inverting the valve
- Self-cleaning metering orifice
- Self-locking adjusting screw and locknut
- Fine control at low flows
- Improved Δp values
- Optional hand knob available
- With ISO 4401 / CETOP R35H size5, NFFA D05, DIN 24 340 A10 interface

1. Description

Series SRDB..-10 stack-mounting throttle valves use the well known "sandwich" principle - they are mounted between a size 5 directional valve and another control module or the subplate. In one direction flow is regulated by the throttle orifice setting while in the other direction the integral bypass check valve permits free reverse flow (cracking pressure approximately 0,7 bar). The design of the throttle ensures automatic self-cleaning under reverse flow. By rotating the valve about its short axis, it can be mounted with either of its two inter face surfaces uppermost - one position gives a METER-IN function, the other METER-OUT. The seal plate is always fitted under the valve body i.e. closest to the subplate. This dual function is clearly shown

in symbols 4 and 5. Symbol 4 represents a meter-in function in A; when "flipped over", as in symbol 5, the same unit now provides a meter-out function in A. Similar comparisons apply to symbols 1 and 2, 3 and 6. The meter-in function is normally used when there is a steady resistance from the cylinder or motor (symbols 2, 4 and 6). If however, the external load varies greatly, perhaps even becoming negative, then the additional resistance generated by the meter-out function may provide better overall control of the actuator. To set the throttle orifice, use a 4 A/F hex. key in the end of the self-locking adjusting screw. The 13 A/F locknut provides additional security. Optionally available with hand-knob adjuster.

2. Symbols

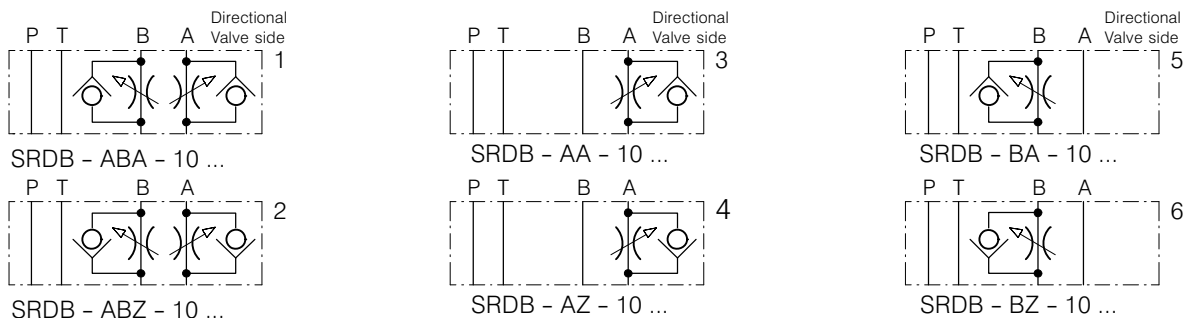

3. Main characteristics

| | | |
|---------------------------------|-------|--|
| Designation | | stacking throttle / check valve |
| Design | | direct acting, spool type |
| Mounting method | | stack mounting |
| Size | | ISO 4401 size 5 interface |
| Weight | kg | SRD...-A.. / B..-10... = 2,80; SRD...-AB..-10... = 2,90 |
| Mounting attitude | | unrestricted |
| Flow direction | | see symbols |
| Operating pressure range (max.) | bar | 350 |
| Cracking pressure (approx.) | bar | 0,7; free flow |
| Flow rate, Q_{max} | l/min | 160, see performance graphs |
| Fluids | | HL and HLP hydraulic oils to DIN 51 524; for other fluids, please consult BUCHER |
| Fluid temperature range | °C | -25 ... +80 |

Reference: 400-P-431101-EN-01

| | | |
|---------------------------------|--------------------------|--|
| Ambient temperature | °C | -25 ... +80 |
| Viscosity range | mm ² /s (cSt) | 10 ... 650 mm ² /s, recommended 15 ... 250 mm ² /s |
| Minimum fluid cleanliness level | | 20/18/15 to ISO 4406 : 1999 |

4. Application example

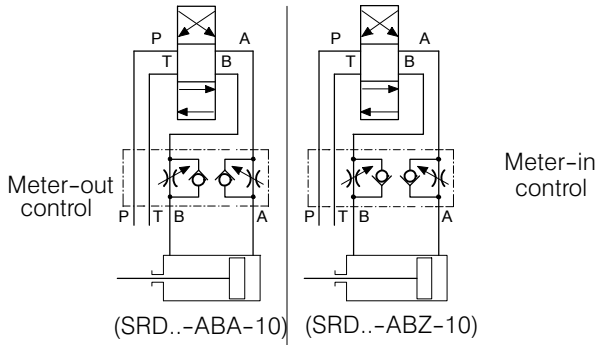

5. Performance graphs

Measured with oil viscosity 33 mm²/s (cSt)

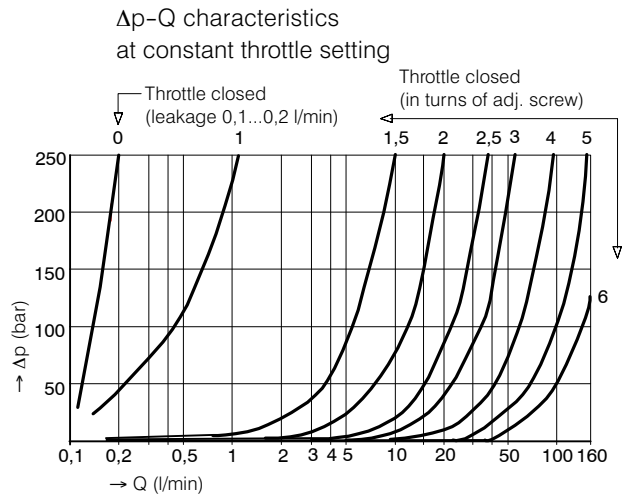
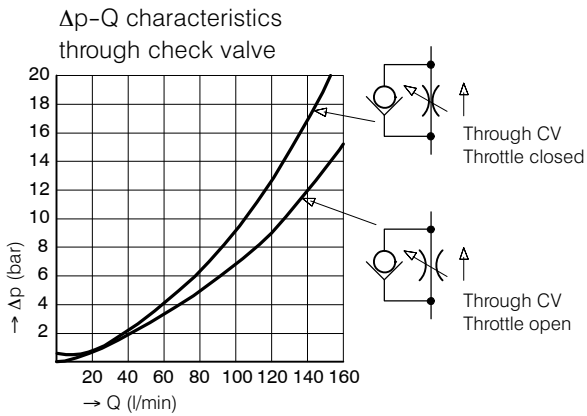

6. Dimensions

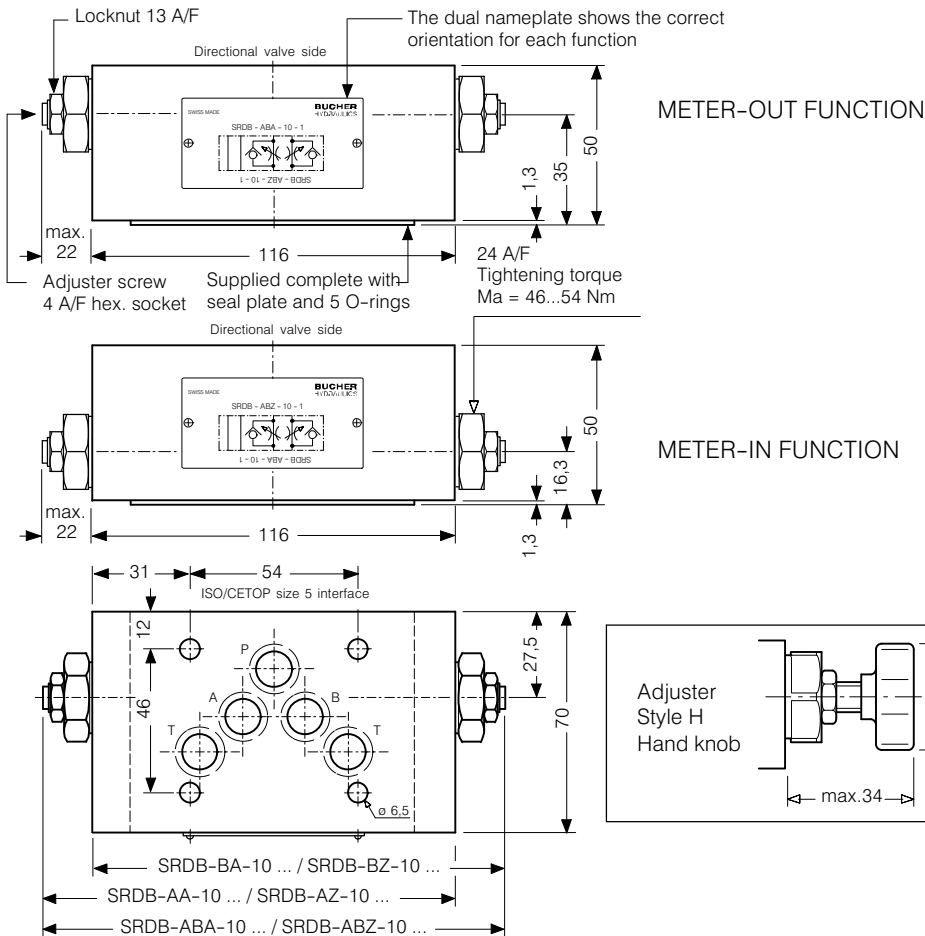

7. Schematic section

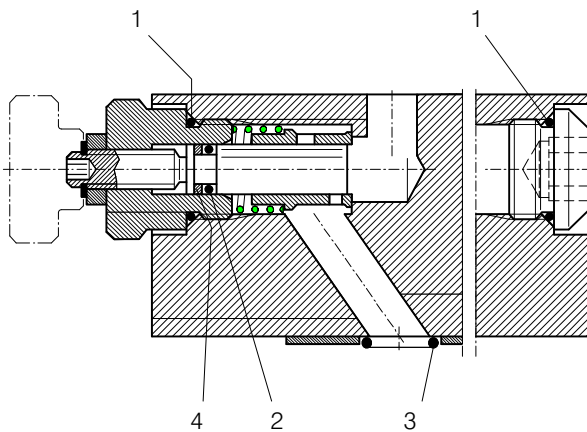

Seal kit no. DS-214, comprising *):

| Itm. | Qty. | Qty. | Description | Size |
|------|------|------|----------------|---|
| 1 | 2*) | 2 | O-ring no. 017 | $\varnothing 17,17 \times 1,78 \text{ N90}$ |
| 2 | 2*) | 1 | O-ring no. 108 | $\varnothing 6,02 \times 2,62 \text{ N90}$ |
| 3 | 5*) | 5 | O-ring no. 014 | $\varnothing 12,42 \times 1,78 \text{ N90}$ |
| 4 | 2*) | 1 | Backup ring | $\varnothing 5,4 \times 1,7 \times 1,0$ |

SRD...AA/BA-10 / SRD...AZ/BZ-10
SRD...ABA-10 / SRD...ABZ-10

8. Installation and servicing

All installation and servicing must be carried out with care, and by qualified personnel only. At installation, be sure to mount the valve the correct way up to produce the required

metering function. Use the specified tightening torque for the guide nut. When changing seals, the new seals should be thoroughly oiled or greased before they are fitted.

9. Ordering code

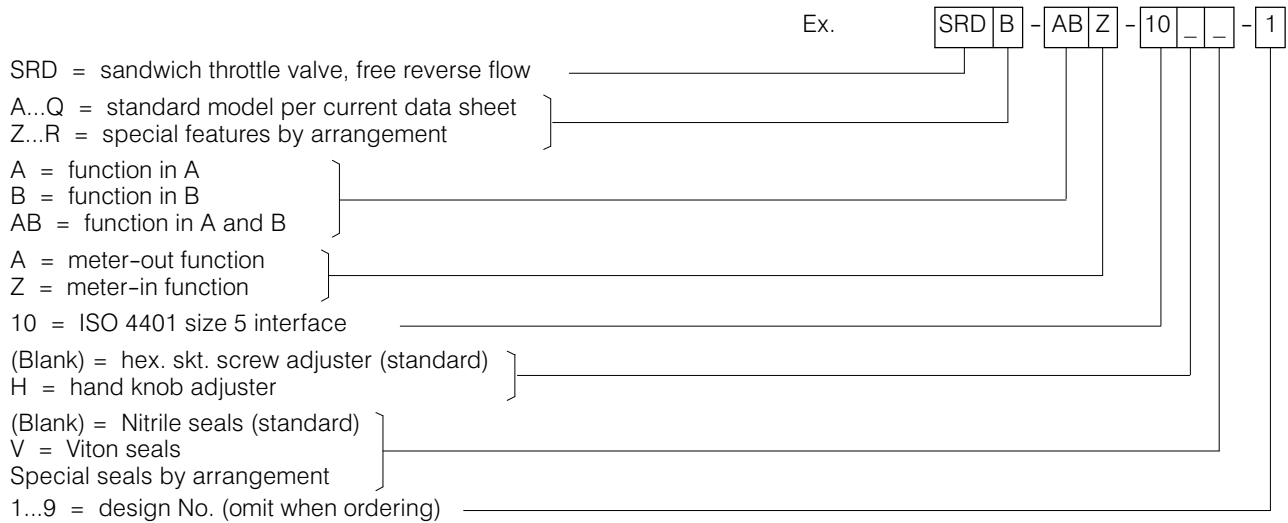

10. Related data sheets

New no.

| | |
|--------------|-------------------------------------|
| 400-P-050101 | DIN 24 340 A10 interface |
| 400-P-810901 | Seal Plate 10 mm |
| 400-P-407101 | Throttle / Check valve type RDB ... |

info.ch@bucherhydraulics.com

www.bucherhydraulics.com

© 2018 by Bucher Hydraulics AG Frutigen, CH-3714 Frutigen

All rights reserved.

Data is provided for the purpose of product description only, and must not be construed as warranted characteristics in the legal sense. The information does not relieve users from the duty of conducting their own evaluations and tests. Because the products are subject to continual improvement, we reserve the right to amend the product specifications contained in this catalogue.

Classification: 450325.330.315.355